

Science needs for continued development of total nitrogen deposition budgets in the United States



National Atmospheric Deposition Program
Total Deposition Science Committee

Authors

Lead authors

John T. Walker *U.S. Environmental Protection Agency, Office of Research and Development, Durham, NC*

Gregory M. Beachley *U.S. Environmental Protection Agency, Office of Air and Radiation, Washington, DC*

Contributing authors in alphabetical order

Helen M. Amos *S&T Policy Fellow, American Association for the Advancement of Science, Hosted by U.S. Environmental Protection Agency, Office of Research and Development, Washington, DC*

Jill S. Baron *U.S. Geological Survey, Fort Collins Science Center, Fort Collins, CO*

Jesse Bash *U.S. Environmental Protection Agency, Office of Research and Development, Durham, NC*

Ralph Baumgardner *U.S. Environmental Protection Agency, Office of Research and Development, Durham, NC*

Michael D. Bell *National Park Service, Air Resources Division, Lakewood, CO*

Katherine Benedict *Colorado State University, Department of Atmospheric Science, Fort Collins, CO*

Xi Chen *U.S. Environmental Protection Agency, Office of Research and Development, Durham, NC*

David W. Clow *U.S. Geological Survey, Colorado Water Science Center, Denver, CO*

Amanda Cole *Environment and Climate Change Canada, Air Quality Research Division, Toronto, ON, Canada*

Justin G. Coughlin *U.S. Environmental Protection Agency, Region 5, Chicago, IL*

Karelyn Cruz *USDA National Institute of Food and Agriculture, Washington, DC*

Ryan W. Daly *U.S. Environmental Protection Agency, Office of Research and Development, Durham, NC*

Stephen M. Decina *University of California, Berkeley, CA*

Emily M. Elliott *University of Pittsburgh, Department of Geology & Environmental Science, Pittsburgh, PA*

Mark E. Fenn *U.S. Department of Agriculture, Forest Service, Pacific Southwest Research Station, Riverside, CA*

Laurens Ganzeveld *Meteorology and Air Quality (MAQ), Wageningen University and Research Centre, Wageningen, Netherlands*

Kristi Gebhart *National Park Service, Air Resources Division, Fort Collins, CO*

Selma S. Isil *Wood Environment & Infrastructure Solutions, Inc., Newberry, FL*

Brian M. Kerschner *Prairie Research Institute, University of Illinois, Champaign, IL*

Robert S. Larson *Wisconsin State Laboratory of Hygiene, University of Wisconsin, Madison, WI*

Thomas Lavery *Environmental Consultant, Cranston, RI*

Gary G. Lear	<i>U.S. Environmental Protection Agency, Office of Air and Radiation, Washington, DC (recently retired)</i>
Taylor Macy	<i>U.S. Environmental Protection Agency, Office of Air and Radiation, Washington, DC</i>
M. Alisa Mast	<i>U.S. Geological Survey, Denver, CO</i>
Kevin Mishoe	<i>Wood Environment & Infrastructure Solutions, Inc., Newberry, FL</i>
Kristi H. Morris	<i>National Park Service, Air Resources Division, Lakewood, CO</i>
Pamela E. Padgett	<i>U.S. Department of Agriculture, Forest Service, Pacific Southwest Research Station, Riverside, CA</i>
Richard V. Pouyat	<i>U.S. Department of Agriculture, Forest Service, Bethesda, MD (recently retired)</i>
Melissa Puchalski	<i>U.S. Environmental Protection Agency, Office of Air and Radiation, Washington, DC</i>
Havala O. T. Pye	<i>U.S. Environmental Protection Agency, Office of Research and Development, Durham, NC</i>
Anne W. Rea	<i>U.S. Environmental Protection Agency, Office of Research and Development, Durham, NC</i>
Mark F. Rhodes	<i>D&E Technical, Urbana, IL</i>
Christopher M. Rogers	<i>Wood Environment & Infrastructure Solutions, Inc., Newberry, FL</i>
Rick Saylor	<i>National Oceanic and Atmospheric Administration, Air Resources Laboratory, Oak Ridge, TN</i>
Richard Scheffe	<i>U.S. Environmental Protection Agency, Office of Air Quality Planning and Standards, Durham, NC (recently retired)</i>
Bret A. Schichtel	<i>National Park Service, Cooperative Institute for Research in the Atmosphere, Colorado State University, Fort Collins, CO</i>
Donna B. Schwede	<i>U.S. Environmental Protection Agency, Office of Research and Development, Durham, NC</i>
Graham A. Sexstone	<i>U.S. Geological Survey, Colorado Water Science Center, Denver, CO</i>
Barkley C. Sive	<i>National Park Service, Air Resources Division, Lakewood, CO</i>
Pamela H. Templar	<i>Boston University, Boston, MA</i>
Tammy Thompson	<i>S&T Policy Fellow, American Association for the Advancement of Science, Hosted by U.S. EPA National Center for Environmental Economics, Washington, DC</i>
Daniel Tong	<i>George Mason University and NOAA Air Resources Laboratory, College Park, MD</i>
Gregory A. Wetherbee	<i>U.S. Geological Survey, Hydrologic Networks Branch, Denver, CO</i>
Thomas H. Whitlow	<i>Cornell University, Ithaca, NY</i>
Zhiyong Wu	<i>U.S. EPA, Office of Research and Development, Durham, NC</i>
Zhongjie Yu	<i>Department of Geology & Environmental Science, University of Pittsburgh, Pittsburgh, PA</i>
Leiming Zhang	<i>Environment and Climate Change Canada, Air Quality Research Division, Toronto, ON, Canada</i>

Citation

Walker, J.T., Beachley, G.M., Amos, H.M., Baron, J.S., Bash, J., Baumgardner, R., Bell, M.D., Benedict, K.B., Chen, X., Clow, D.W., Cole, A., Coughlin, J.G., Cruz, K., Daly, R.W., Decina, S.M., Elliott, E.M., Fenn, M.E., Ganzeveld, L., Gebhart, K., Isil, S.S., Kerschner, B.M., Larson, R.S., Lavery, T., Lear, G.G., Macy, T., Mast, M.A., Mishoe, K., Morris, K.H., Padgett, P.E., Pouyat, R.V., Puchalski, M., Pye, H.O.T., Rea, A.W., Rhodes, M.F., Rogers, C.M., Saylor, R., Scheffe, R., Schichtel, B.A., Schwede, D.B., Sexstone, G.A., Sive, B.C., Templer, P.H., Thompson, T., Tong, D., Wetherbee, G.A., Whitlow, T.H., Wu, Z., Yu, Z., Zhang, L. 2019. Science needs for continued development of total nitrogen deposition budgets in the United States. U.S. Environmental Protection Agency, Washington, DC, EPA 601/R-19/001.

Cover photo *View from eddy flux tower, USDA Forest Service, Coweeta Hydrologic Laboratory, Otto, NC. Photo courtesy of John T. Walker.*

Acronyms and chemical formulas

AAI	Aquatic Acidification Index
ACCMIP	Atmospheric Chemistry and Climate Model Intercomparison Project
ADAGIO	Atmospheric Deposition Analysis Generated by optimal Interpolation from Observations
AFO	animal feeding operations
AFRI	Agriculture and Food Research Initiative
AGM	Aerodynamic Gradient Method
AIRMoN	Atmospheric Integrated Research Monitoring Network
AIRS	Atmospheric Infrared Sounder
AMNet	Atmospheric Mercury Network
AMoN	Ammonia Monitoring Network
AMS	aerosol mass spectrometer
AN	alkyl nitrates
APD	absolute percent difference
APN	acyl peroxy nitrates
AQMEII	Air Quality Model Evaluation International Initiative
AQS	air quality system
ARS	Agricultural Research Service
ASRC	Atmospheric Science Research Center
BEIS	Biogenic Emissions Inventory System
BFM	brute force method
BMPs	best management practices
BLM	Bureau of Land Management
BVOC	biogenic volatile organic compound
CAAA	Clean Air Act Amendments
CAFO	Confined Animal Feeding Operation
CAMD	Clean Air Markets Division

CAMx	Comprehensive Air quality Model with eXtensions
CaPA	Canadian Precipitation Analysis
CAPMoN	Canadian Air and Precipitation Monitoring Network
CASAC	Clean Air Scientific Advisory Committee
CASCC	Caltech Active Strand Cloud Water Collector
CASTNET	Clean Air Status and Trends Network
CEMS	continuous emissions monitoring systems
CH ₄	methane
CH ₃ CN	acetonitrile
C ₂ H ₇ N	ethylamine
C ₇ H ₅ N	benzonitrile
C ₂ H ₅ NO	acetamide
CIMS	chemical ionization mass spectrometry
CL	Critical Load
CLAD	Critical Load Atmospheric Deposition Science Committee
CMAQ	Community Multi-scale Air Quality model
CO	carbon monoxide
COTAG	Conditional Time-Averaged Gradient
CrIS	Cross-track Infrared Sounder
CSA	combined statistical area
CSN	Chemical Speciation Network
CSU	Colorado State University
CTMs	chemical transport models
CV	coefficient of variation
DDM	direct decoupled method
DON	dissolved organic nitrogen
EC	eddy covariance
ECCC	Environment and Climate Change Canada
EGU	electrical generation unit
EMEP	European Modeling Evaluation Program
EOS	Education and Outreach Subcommittee
EPA	United States Environmental Protection Agency
EPIC	Environmental Policy Integrated Climate
ESA	European Space Agency
ESI	electrospray ionization
FASMEE	Fire and Smoke Model Evaluation Experiment
FEM	farm emission model
FEST	Fertilizer Emission Scenario Tool
FIA	Forest Inventory and Analysis
FTIR	fourier-transform infrared
FWS	United States Fish and Wildlife Service
GC	gas chromatography
GEIA	Global Emissions InitiAtive
GEM-MACH	Global Environmental Multi-scale - Modeling Air quality and CHEmistry

GFDL	Geophysical Fluid Dynamics Laboratory
GIS	geographic information systems
GOME	Global Ozone Monitoring Experiment
HA-QAST	Health and Air Quality Applied Science Team
HCN	hydrogen cyanide
HDPE	high-density polyethylene
HNCO	isocyanic acid
HNO ₃	nitric acid
HONO	nitrous acid
HO ₂ NO ₂	peroxynitric acid (PNA)
HYSPLIT	Hybrid Single-Particle Lagrangian Integrated Trajectory Model
IASI	Infrared Atmospheric Sounder Interferometer
ICR	ion cyclotron resonance
IDW	inverse distance weighted
IER	ion exchange resin
iLEAPS	Integrated Land Ecosystem-Atmosphere Process Study
IMPROVE	Interagency Monitoring of Protected Visual Environments
INC	Integrated Nitrogen Committee
ISA	Integrated Science Assessment
ISAM	integrated source apportionment method
ISOPN	isoprene hydroxy nitrates
ISS	improved spacial surrogate
KMT	kinetic mass transfer
LAI	Leaf -area indexes
LC	Liquid chromatography
LTER	Long-term Term Ecological Research Network
LIF	laser induced fluorescence
LRTAP	Long-range range Transboundary Air Pollution
LWC	liquid water content
MAD	mean absolute difference
MADPRO	Mountain Acid Deposition Program
MAPD	mean absolute percent difference
MARPD	median absolute relative percent difference
MBR	modified Bowen ratio
MCCP	Mountain Cloud Chemistry Program
MDN	Mercury Deposition Network
MEGAN	Model of Emissions of Gases and Aerosols from Nature
MLM	multilayer model
MMF	measurement-model fusion
MODIS	Moderate Resolution Imaging Spectrometer
MOST	Monin-Obukhov similarity theory
MPAN	peroxymethacryloyl nitrate
MPE	model performance evaluation
MS	mass spectrometry

NAAQS	National Ambient Air Quality Standards
NAEMS	National Emissions Monitoring Study
NAPS	National Air Pollution Surveillance Program
NAQFC	National Air Quality Forecast Capability
NASA	National Aeronautics and Space Administration
NCO ⁻	cyanate ion
NEI	National Emissions Inventory
NH ₃	ammonia
NH ₄ ⁺	ammonium
NH ₄ NO ₃	ammonium nitrate aerosol
NH _x	reduced nitrogen, ammonia + ammonium
NIFA	National Institute of Food and Agriculture
NO ₂	nitrogen dioxide
NO ₂ ⁻	nitrite
NO ₃ ⁻	nitrate
N ₂ O	nitrous oxide
NOS	Network Operations Subcommittee
NO _x	oxides of nitrogen consisting of NO and NO ₂
NO _y	oxidized nitrogen consisting of all oxidized nitrogen compounds including NO _x
NO _z	The component of oxidized nitrogen (NO _y) excluding NO _x (i.e. NO _y = NO _z + NO _x)
NOAA	National Oceanic and Atmospheric Administration
NPS	National Park Service
Nr	reactive nitrogen
NRC	National Research Council
NRCS	National Resources Conservation Service
NTN	National Trends Network
O ₃	ozone
OFD	optical fog detector
OMI	ozone monitoring instrument
ON	organic nitrogen
OPAN	aromatic peroxyacyl nitrates
OSAT	ozone source apportionment tool
PAN	peroxyacyl nitrates
PAN _x	C3 and higher PANs
PAH	polyaromatic hydrocarbon
Pb	lead
PM	particulate matter
PMF	positive matrix factorization
PN	peroxynitrate
PO ₄ ⁻³	phosphate
ppm	parts per million
PPN	peroxypropionyl nitrate
PRACS	Puerto Rico Aerosol and Clouds Study
PSAT	particulate source apportionment tool

PSD	prevention of significant deterioration
PTR	proton-transfer-reaction
PVM	particulate volume monitor
QA/QC	quality assurance/quality control
QCL	quantum cascade laser
RACM	Regional Atmospheric Chemistry Mechanism
REA	relaxed eddy accumulation
RFA	request for application
RH	relative humidity
RMNP	Rocky Mountain National Park
RMS	root mean square
RMSE	root mean square error
RPD	Relative percent difference
S	sulfur
SA	source apportionment
SAB	Science Advisory Board
SANDS	Southern Appalachian Nitrogen Deposition Study
SBM	San Bernardino Mountains
SCIAMACHY	SCanning Imaging Absorption spectroMeter for Atmospheric CHartography
SCR	selective catalytic reduction
SEARCH	Southeastern SouthEastern Aerosol Research and Characterization network
sf-CASCC	size fractionating-Caltech Active Strand Clod Water Collector
SJAC	steam jet aerosol collector
SNP	Sequoia National Park
SO ₂	sulfur dioxide
SOA	secondary organic aerosol
SOx	oxides of sulfur
TDep	Total Deposition Science Committee
TDL	tunable diode laser
TEA	triethanolamine
TEMPO	Tropospheric Emissions: Monitoring of POLLution
TES	Tropospheric Emissions Spectrometer
TMDL	Total Maximum Daily Load
T-Ratios	transference ratios
TSSA	tagged species source apportionment
TVA	Tennessee Valley Authority
TWC	three-way catalytic converter
UNECE	United Nations Economic Commission for Europe
USDA	United States Department of Agriculture
USFS	United States Forestry Service
FWS	United States Fish and Wildlife Service
USGS	United States Geological Survey
VCD	vertical column density
VOC	volatile organic compounds

VOCALS	VAMOS Ocean-Cloud-Atmosphere-Land Study Regional Experiment
VSMOW	Vienna Standard Mean Ocean Water
WRF	Weather Research and Forecasting model
WSTN	Water soluble fraction of total nitrogen

Table of Contents

1. Background and Purpose	12
2. Policy Relevance of Nr Deposition	15
2.1 Air Regulations Relevant to Nr	15
2.2. Critical Loads of Nutrients and Acidity	17
2.3. Overarching Policy-Relevant Science Questions.....	19
3. Deposition Research Topics and Knowledge Gaps	19
3.1. Measured Total Nr Deposition Budgets.....	27
3.1.1. Process-Level Measurements.....	28
3.1.1.1. Measurements of air-surface exchange of Nr in natural ecosystems across North America	30
3.1.1.2. Measurements of surface chemistry and wetness relevant to fluxes	60
3.1.1.3. Advancing throughfall methods for quantifying Nr deposition	68
3.1.1.4. Total atmospheric Nr deposition in urban areas.....	80
3.1.1.5. Snow and atmospheric deposition	94
3.1.1.6. Occult deposition: what we know, don't know, and should really know	107
3.1.2. Routine Monitoring	129
3.1.2.1. Wet deposition annual precipitation-weighted mean concentrations from incomplete time series: Influence of completeness criteria, data validation, and data substitution methods.....	130
3.1.2.2. Satellite measurements of oxidized and reduced nitrogen for application to Nr budgets	154
3.1.2.3. Linking of air concentrations to deposition via transference ratios.....	172
3.1.2.4. Low-cost method for routine monitoring of air-surface exchange of Nr compounds	177
3.1.2.5 Characterization of organic nitrogen in air and precipitation	185
3.2. Modeled Total Nr Deposition Budgets.....	213
3.2.1. Application of a bidirectional ammonia air-surface exchange model at NADP AMoN sites.....	214
3.2.2. Development of in-canopy source/sink models that resolve deposition to ecosystem components (crown, understory, ground) and in-canopy chemistry	233
3.2.3. Modeling fluxes of Nr using chemical transport models	244

3.2.4. Assessing uncertainty in total Nr deposition estimates for North American critical load applications.....	271
3.3. Source Contributions to Total Nr Deposition.....	303
3.3.1. Development and testing of source, receptor, and hybrid-oriented apportionment methods.....	304
3.3.2. Isotopic advances in understanding Nr deposition.....	318
3.4. Spatial and Temporal Patterns of Total Nr Deposition.....	339
3.4.1. Relationship of long-term Nr trends in emission and deposition.....	340
3.4.2. Spatial variability of ammonia in agricultural regions.....	363
4. Enhanced Coordination to Address Stakeholder Issues and Resource Needs.....	378
4.1. Stakeholder Needs and Opportunities for Coordination.....	379
4.1.1. Improved understanding of the linkages between agricultural emissions and Nr deposition.....	379
4.1.2. Better characterization of patterns and trends in Nr deposition.....	381
4.1.3. Quantifying and reducing uncertainty in deposition estimates used for critical loads applications.....	383
4.2. Strategies for Increasing Stakeholder Coordination.....	384
5. From Deposition to Ecosystem Response.....	385
6. References (Sections 1, 2, 4, and 5).....	387

1. Background and Purpose

Over the past two decades, interest in better understanding atmospheric inputs of reactive nitrogen (Nr; all biologically active, chemically reactive, and photochemically active nitrogen compounds) to terrestrial and aquatic ecosystems has increased dramatically within the National Atmospheric Deposition Program (NADP) user community. ‘Nitrogen deposition’ refers to the transfer of these Nr-containing compounds from the atmosphere to the Earth’s surface. Atmospheric inputs occur via wet deposition processes through which gases and particles are first incorporated into hydrometers and then delivered to the surface through precipitation, or by dry deposition processes through which gases and particles deposit to surfaces directly. Wet and dry deposition processes considered together represent “total” Nr deposition.

Nitrogen deposition is an important step in the nitrogen cascade concept, which describes the cycling of Nr between the atmosphere and biosphere (Galloway et al., 2003). The amount of Nr in the environment has doubled globally over the past century and increased many-fold in certain geographic regions (Fowler et al., 2013) owing largely to anthropogenic processes including the production of fertilizer and other industrial applications via the Haber-Bosch process and the conversion of both non-reactive atmospheric (i.e. N₂) and fuel-bound N during fossil fuel combustion. Excess deposition of Nr to terrestrial ecosystems can lead to soil acidification or eutrophication, and damage to trees, herbs, and lichen through direct uptake from the atmosphere. Deposition (and runoff) to aquatic systems can cause eutrophication and acidification of lakes, streams, and other water bodies. These ecosystem changes can lead to reduced biodiversity and reduced resilience to climate variability and other stressors (U.S. EPA, 2008) and can be directly or indirectly linked to decreases in the quality of benefits provided by ecosystems, including clean water, climate regulation, food, recreational opportunities, and cultural and spiritual value (Compton et al., 2011; Cooter et al., 2013; Munns et al., 2016a; Clark et al., 2017; Rhodes et al., 2017). The recognition that the atmosphere plays a key role in providing these ecosystem services (Cooter et al., 2013; Rea et al., 2012; Thornes et al., 2010) has underscored the need to develop accurate and complete atmospheric Nr deposition budgets.

A fundamental aspect of characterizing ecosystem risk from excess Nr is quantification of the amount of Nr entering the ecosystem relative to the ecosystem’s “critical load”. The critical load is defined as *“a quantitative estimate of an exposure to one or more pollutants below which significant harmful effects on specified sensitive elements of the environment do not occur according to present knowledge”* (Nilsson and Grennfelt, 1988). The development of critical loads for Nr requires an understanding of the total amount of Nr in atmospheric deposition. In terrestrial ecosystems, such as temperate forests, where N₂ fixation rates are low, atmospheric deposition can be the primary source of excess Nr. The contribution of atmospheric Nr inputs in aquatic ecosystems is lower, although still important. For example, the Chesapeake Bay estuary is situated in a highly populated area with extensive agricultural operations, yet 33% of the total N-loading to the watershed in 2015 is due to atmospheric deposition (U.S. EPA, 2010).

The NADP monitors precipitation chemistry at approximately 250 sites across North America (<http://nadp.slh.wisc.edu>). The program is a cooperative effort between federal, state, tribal and local governmental agencies, educational institutions, private companies, and non-governmental agencies. NADP provides data on the amounts, trends, and geographic distributions of acids, nutrients, and base cations in precipitation. While the National Trends Network (NTN), which monitors weekly precipitation chemistry, represents the core of NADP, the program has expanded since its origin in 1978 to include additional sub-networks, including the Atmospheric Integrated Research Monitoring Network (AIRMoN), Mercury Deposition Network (MDN), Atmospheric Mercury Network (AMNet), and most recently the Ammonia Monitoring Network (AMoN).

The organizational structure of NADP includes an Executive Committee, which provides program direction and acts on recommendations of the Budget Advisory Committee and Quality Assurance Advisory Group. Two technical subcommittees advise the Executive Committee on issues such as field-siting criteria, equipment, and laboratory and sample collection protocols (Network Operations Subcommittee, NOS) and provide input on data user needs and outreach (Education and Outreach Subcommittee, EOS). In addition to the technical subcommittees, the program includes two science committees focused on key areas of atmospheric deposition of interest to NADP data users. These include the Critical Loads Atmospheric Deposition Science Committee (CLAD), which facilitates the development and use of critical loads for quantifying atmospheric deposition impacts to ecosystems, and the Total Deposition Science Committee (TDep).

TDep formed in 2011 with the mission to improve estimates of atmospheric deposition by advancing the science of measuring and modeling atmospheric wet, dry, and total deposition of species such as sulfur, N, and mercury. TDep is a forum for the exchange of information on current and emerging issues among atmospheric scientists, ecosystem scientists, resource managers, and policy makers. The specific charges of TDep (<http://nadp.slh.wisc.edu/committees/tdep/>) are to:

- support national networks that monitor atmospheric deposition by providing information on emerging measurement techniques, model development, and uncertainties associated with these approaches
- identify and prioritize knowledge gaps in the field of measuring and modeling atmospheric deposition and advocate for research to address those gaps
- coordinate with CLAD and other groups to advocate the use of the most scientifically defensible deposition estimates for critical loads and other environmental assessments
- provide expertise and advice on present and potential decisions and regulatory actions pertaining to the field of measuring and modeling atmospheric deposition
- encourage greater communication and collaboration between groups from different disciplines with interests in atmospheric deposition.

One of TDep's major accomplishments to date is the establishment of a method that combines values from measurements and output from atmospheric models to produce maps of total Nr deposition (Schwede and Lear, 2014). These maps are a formal NADP product and have been used to determine critical load exceedances in national parks (NPS, 2014) and Forest Service lands (USFS, 2016). It is important to note that the deposition budgets on which critical loads are based often contain significant uncertainties in measurements and models, their accuracy and completeness being reflective of the current state of science. Factors that contribute to spatial and temporal variability in atmospheric deposition processes include meteorological phenomena governing transport and diffusion, chemical reactions of pollutants in the atmosphere and at the depositing surface, and biological processes within specific ecosystems. Where deposition estimates are derived from chemical transport models, uncertainties unrelated to the deposition process itself, such as emissions of Nr to the atmosphere, become important. More experimental knowledge of measurable parameters, leading to improvements in deposition models, is needed to help to address these uncertainties.

In the spring of 2016, the TDep committee successfully renewed its charter before the NADP Executive Committee, citing the total deposition maps as one of several accomplishments. Key to the renewal was the plan to identify knowledge gaps, such as the uncertainties in total deposition estimates mentioned above, and prioritize and facilitate a set of priority research needs which TDep and collaborators will address over the next several years. The needs are areas in which advances in measurements and modeling of Nr deposition as well as improved understanding of sources of Nr are needed to improve total Nr deposition budgets. The TDep steering committee moved forward with a plan for a white paper, outlining these priority research needs, to serve as a "road map" for TDep research activities. ***The objectives of this white paper are to describe the state of the science with respect to total Nr deposition budgets in the United States and the research needed to improve these budgets from both measurement and modeling perspectives. The document is intended to serve as a plan for TDep research activities but also, more broadly, to provide program managers, natural resource managers, policy makers and scientists with an understanding of (1) the need for complete and accurate Nr deposition budgets to protect ecosystem health and human welfare, and (2) the linkages between the underlying policy-relevant science questions and the specific knowledge and data gaps needed to improve Nr deposition budgets.***

The document is structured by first providing background on the current regulatory policies relevant to atmospheric Nr (Section 2). A set of policy-relevant science questions specifically related to Nr deposition is then presented (Section 2). These questions motivate detailed descriptions of specific 'research topics' presented in Section 3, each supported by a brief discussion of the underlying state-of-the-science and the identification of 'knowledge gaps' within those topics. This format builds on a review of knowledge gaps in deposition science put forth in a prior TDep assessment and represents a combination of core needs relevant to TDep's mission, such as datasets of deposition fluxes in key ecosystems and improvement of deposition algorithms in regional chemical transport models, as well as new areas, such as source apportionment of Nr deposition. The research topics and their key knowledge gaps are summarized in Table 3.1. Section 3 was developed by experts across a range of disciplines

within the TDep community including atmospheric chemistry and physics, biogeochemistry, ecology, numerical modeling, micrometeorology, and remote sensing, including representatives from within TDep as well as external federal, state, and academic collaborators. Opportunities for integrating research across the many stakeholders that benefit from Nr deposition science are put forth in Section 4 and a brief summary of the document is included in Section 5.

2. Policy Relevance of Nr Deposition

2.1 Air Regulations Relevant to Nr

The National Ambient Air Quality Standards (NAAQS), established under the Clean Air Act, include primary standards to protect public health and secondary standards to protect public welfare. The Clean Air Act definition of “welfare” includes effects on soils, water, vegetation, visibility, weather, climate, wildlife, materials, economic values, and personal comfort and well-being (CAA 302[h]). The secondary standard for nitrogen dioxide (NO₂), which establishes a limit of 0.053 parts per million (ppm) annual average concentration, is the standard most directly relevant to Nr deposition. In addition to establishing the standards themselves, the Clean Air Act requires periodic review and, as necessary, revision of the NAAQS. Central to the NAAQS review process is the Integrated Science Assessment (ISA), which is a comprehensive synthesis and evaluation of the most policy-relevant science related to the standard. The ISA (U.S. EPA, 2008) informs the Risk and Exposure Assessment, which determines if known or anticipated effects to public welfare are occurring or are anticipated to occur under current conditions (U.S. EPA, 2009), and, ultimately, the Policy Assessment (U.S. EPA, 2011a), which provides the EPA Administrator with policy options for retaining or revising the current standards. The review culminates with a final ruling in which the decision to retain or modify the NAAQS standard is documented in the Federal Register (U.S. EPA, 2012). The most recent review was completed in 2012 and a new review was initiated in 2016 (U.S. EPA, 2016).

Due to their combined effects on atmospheric chemistry, deposition processes, ecosystem health and public welfare, the secondary standards for NO₂ and sulfur dioxide (SO₂) (0.5 ppm 3-hour average air concentration) were most recently reviewed together (Final Rule, U.S. EPA, 2012), referred to here as the Integrated Science Assessment for Oxides of Nitrogen (NO_x) and Sulfur (SO_x) or NO_x/SO_x ISA (U.S. EPA, 2008). The current assessment also includes particulate matter (NO_x/SO_x/PM, U.S. EPA, 2016). It is important to note that the current NAAQS standards are concentration based, however, the NAAQS review encompasses ecosystem effects resulting from direct exposure to atmospheric concentrations as well as atmospheric deposition, understanding that deposition rates are fundamentally linked to atmospheric concentrations. Additionally, the scope of the review is not limited to the specific indicators of the current standards (e.g., NO₂, SO₂, PM). The most recently completed (NO_x/SO_x) and ongoing (NO_x/SO_x/PM) ISAs acknowledge that comprehensive assessment of the ecological effects of atmospheric Nr deposition requires consideration of the suite of chemical forms that make up Nr. The ISA therefore evaluates data on all oxidized, reduced (ammonia (NH₃) and ammonium (NH₄⁺), NH₃ + NH₄⁺ = NH_x), and organic forms of Nr in atmospheric deposition.

Science conducted by the TDep community was utilized in the NO_x/SO_x secondary NAAQS review.

The main effects of Nr deposition assessed by the NO_x/SO_x ISA are acidification and nutrient enrichment. The 2008 NO_x/SO_x ISA concluded that evidence is sufficient to infer a causal relationship between deposition of acidifying species and effects on biota and biogeochemistry related to terrestrial and aquatic ecosystems. Furthermore, the ISA found sufficient evidence to infer a causal relationship between Nr deposition, to which NO_x and NH_x directly contribute, and the alteration of biogeochemical cycling of N and carbon in terrestrial, wetland, freshwater aquatic, and coastal marine ecosystems. Indicators of this relationship include biogenic fluxes of methane (CH₄) and nitrous oxide (N₂O) in terrestrial and wetland ecosystems as well as species richness and species composition in terrestrial, wetland, freshwater aquatic, and coastal marine ecosystems.

The most recent review of the NO_x/SO_x secondary standard, completed in 2012 (U.S. EPA, 2012), represents a significant step forward in setting a multi-pollutant standard to protect public welfare. This review determined that known or anticipated adverse ecological effects are occurring and that the current standards are not adequate to protect against deposition-related effects (U.S. EPA, 2009; 2011b). EPA's Clean Air Scientific Advisory Committee (CASAC), an independent federal advisory group that provides scientific information and advice to EPA officials, concluded that the levels and the form of the current standard are insufficient to protect against adverse effects from deposition, thus warranting revision of the standard (U.S. EPA, 2011b). Although the Administrator agreed with the CASAC, she concluded it was premature to set a new, multi-pollutant secondary standard for oxides of N and sulfur due to the high level of uncertainty related to setting the form, indicator, and level of the standard (U.S. EPA 2011b). These scientific uncertainties in relating atmospheric concentrations to deposition and data gaps nationwide underscore the need for the science that the TDep and CLAD communities are conducting.

In addition to the secondary NAAQS, Nr is considered in other air quality regulations, including the primary NAAQS and the Regional Haze Rule. The primary NAAQS provides human health protection (rather than public welfare) and sets air concentration limits for several pollutants that are known to be harmful to human health, including carbon monoxide (CO), lead (Pb), NO₂, ozone (O₃), SO₂, and PM. Atmospheric Nr directly contributes to both the formation of O₃ and PM (Galloway et al., 2003; Fowler et al., 2013). Oxidized nitrogen gases are primary precursors of tropospheric O₃ formation and are important to O₃ control strategies. Nr also reacts with organic carbon compounds leading to secondary organic aerosol (SOA) and both reduced (NH_x) and oxidized forms of Nr play a role in the formation of inorganic PM, specifically NH₄⁺ containing compounds. The Nr-containing organic and inorganic PM compounds are typically small in diameter (< 2.5 μm) and contribute significantly to the total mass of PM in the atmosphere. Atmospheric PM is not only a concern for human health but also for its effects on atmospheric conditions such as visibility and processes such as climate forcing. PM is a component of atmospheric haze and impacts visibility, for which there are regulatory requirements intended to protect natural areas where scenic views are a valued ecosystem

service. The Regional Haze Rule, enacted in 1999, calls for States to establish goals and emission reduction strategies for improving visibility in all mandatory Class I national parks and wilderness areas (U.S. EPA, 1999).

The importance of Nr in air quality regulations and critical loads frameworks illustrate the complex relationships among not only the regulations themselves but also the atmospheric processes that ultimately lead to ecosystem exposure and effects (Cooter et al., 2013; Rea et al., 2012). These complexities should be considered in developing and implementing strategies to achieve management goals to reduce ecological exposure to Nr deposition. Ammonium nitrate aerosol (NH_4NO_3) is an example that illustrates these complexities which are briefly described here. NH_4NO_3 is formed when NH_3 gas reacts with nitric acid (HNO_3) gas, each of which originating from very different Nr sources that are ultimately linked via aerosol processing. NH_4NO_3 is a component of both wet and dry Nr deposition, and therefore is relevant to the secondary NAAQS review and critical loads. NH_4NO_3 may partition back to gaseous HNO_3 and NH_3 depending on atmospheric temperature and relative humidity, which may then either dry or wet deposit or undergo further atmospheric chemical reactions. NH_4NO_3 contributes to the mass of PM in the atmosphere and to reduced visibility and is therefore being considered in the current $\text{NO}_x/\text{SO}_x/\text{PM}$ Secondary NAAQS review (U.S. EPA, 2016). It is also relevant to the primary NAAQS and Regional Haze Rule, particularly in the western U.S. Strategies to control ambient PM concentrations (NH_4NO_3) which will affect subsequent atmospheric deposition of Nr.

Furthermore, the particular chemical species of emission control targets is important. NO_x emission controls may reduce atmospheric concentrations of NH_4NO_3 in many areas. In other areas, NH_4NO_3 will be more sensitive to atmospheric concentrations of NH_3 , for which there is currently no Federal regulatory mandate for emission controls. Across the U.S., a gradual shift of the inorganic Nr budget from a predominance of oxidized to reduced forms of Nr (Du et al., 2014; Li et al., 2016) highlights the need for consideration of NH_3 in control strategies to address atmospheric deposition of Nr as well as PM. Thus, the origin, atmospheric processing and fate of NH_4NO_3 aerosol is an example of the interconnectivity of Nr from an atmospheric perspective. Science addressing Nr must acknowledge this complexity in developing solutions to better understand and mitigate the impacts of Nr deposition.

2.2. Critical Loads of Nutrients and Acidity

Critical loads are used to quantify the amount of atmospheric deposition (load) that can be tolerated by ecosystems without significant harm or change occurring. In this regard, they are analogous to other risk-based environmental criteria, such as the ambient water quality criteria required by Section 304 (a) (1) of the Clean Water Act that establish protective limits to chemical contaminant exposure in aquatic systems. Critical loads link atmospheric deposition to ecological response based on the threshold of deposition below which negative ecosystem effects do not occur (Nilsson and Grennfelt, 1998). Critical loads have been developed for a number of ecosystem components including terrestrial and aquatic acidification, forest-tree health, NO_3^- leaching, changes in plant community composition, and changes in lichen

communities (Pardo et al., 2011; Clark et al., 2018). Exceedance of the critical load can negatively affect aspects of ecosystem structure and function that produce the ecosystem services that benefit people (Munns et al., 2015; Clark et al., 2017; Rhodes et al., 2017). Ecosystem services include clean air and water, recreational opportunities, visibility, food and materials, and cultural and spiritual values. Atmospheric deposition can be linked to changes in ecosystem services via ecological production functions. For welfare considerations, critical loads can be established based upon the effects of atmospheric deposition on key ecosystem services (Munns et al., 2016b). For example, a critical load for acid neutralizing capacity in lakes and streams can be informed by ecological production functions for recreational fish species abundance, or for nonuse and cultural values (Rea et al., 2012).

Science and policy are closely coupled in the critical loads process (U.S. EPA, 2008; Porter et al., 2005; Fenn et al., 2011; Burns et al., 2015). Examples of scientific aspects of the development of critical loads include relating ambient air concentrations to deposition, quantifying the relationships between deposition and ecosystem response, relating those ecological changes to changes in the services ecosystems provide, and identifying the ecosystems most at risk to deposition. Policy aspects include establishing considerations for identifying which ecosystems to protect, developing emission reduction plans to achieve protective levels of deposition, and evaluating the effectiveness of regulations. By linking air concentrations and atmospheric deposition to ecosystem response in the context of ecological production functions, critical loads provide a quantitative framework that can be used to inform resource management and policy decisions aimed at sustaining or improving human welfare (Munns et al., 2016b).

Critical loads have been used extensively in Europe to support the Convention on Long-range Transboundary Air Pollution (LRTAP) within the United Nations Economic Commission for Europe (UNECE). Maps of critical levels and loads are regularly updated within the LRTAP Working Group on Effects led by the International Cooperative Programme on Modelling and Mapping of Critical Levels and Loads and Air Pollution Effects, Risks and Trends (<http://icpmapping.org/>). Maps of critical load exceedances support pollutant emission reduction strategies developed under the UNECE Convention on LRTAP (UNECE WGE, 2004). The critical load approach has also been used in Canada to design emission reduction programs (Jeffries and Ouimet, 2004).

In the U.S., ambient air concentrations, rather than deposition, have traditionally been used to set the NAAQS. However, in 2004, the National Research Council (NRC) recommended that EPA consider using critical loads for ecosystem protection, which was followed in 2005 by an EPA rule that includes a provision for states to use critical loads as part of their air-quality management strategy to satisfy Clean Air Act requirements regarding “prevention of significant deterioration” (PSD) (U.S. EPA, 2005). PSD addresses the preservation, protection, and enhancement of air quality and air quality related values—ecosystem services—in national parks, national wilderness areas, national monuments, national seashores, and other areas of special national or regional natural, recreational, scenic, or historic value (U.S. Congress, 1977). An “Air Quality Related Value” is defined as a resource that may be adversely affected by a change in air quality and may include visibility or a specific scenic, cultural, physical, biological,

ecological, or recreational resource for a particular area (FLAG, 2000). The 2004 recommendation by the NRC and 2005 EPA ruling were followed by an expansion of critical loads research. Critical loads are now used by EPA as a quantitative framework for linking atmospheric concentrations and deposition to effects on public welfare and thus have become an important assessment tool within the secondary NAAQS review process (Scheffe et al., 2014; Rea et al., 2012). Additionally, U.S. federal land management agencies have adopted critical loads as a tool for setting management goals and guiding air pollution management decisions for national parks, forests, and wilderness areas (Blett et al., 2014; Pardo et al., 2015). Establishment of a critical load for eutrophication in Rocky Mountain National Park (Baron, 2006; Porter and Johnson, 2007) is an example of Federal Agencies (U.S. EPA, Region 8; National Park Service) and States (Colorado Department of Public Health and Environment) working collaboratively to develop and implement an air quality management plan to protect public welfare and ecosystems services by reducing Nr deposition. Accurate and complete deposition budgets of nutrients and acidity are fundamental requirements for the development of critical loads and ultimately for protecting human welfare.

2.3. Overarching Policy-Relevant Science Questions

Deposition science to support the secondary NAAQS and critical load assessments is motivated from a top-down approach by the following over-arching policy-relevant science questions regarding what research related to development of total Nr deposition budgets is needed to:

- Link atmospheric Nr levels and speciation to deposition rates for specific ecosystems?
- Link Nr deposition rates to ecosystem response in terms of critical loads?
- Relate ecosystem responses to Nr deposition to changes in ecosystem services and human welfare?
- Quantify critical loads and their exceedances?
- Reduce uncertainties in estimates of critical loads and exceedances?
- Determine the source(s) of Nr deposition in ecosystems experiencing exceedances?
- Evaluate the effectiveness of existing policies for managing Nr deposition?
- Inform the scientific basis for reviews of policies related to managing Nr deposition?

These policy-relevant science questions comprise a number of more specific research topics, which are described in detail in the following section.

3. Deposition Research Topics and Knowledge Gaps

The research topics motivated by the policy-relevant science questions in Section 2.3 can be categorized into four broader topic areas: measurements of deposition budgets, modeling of deposition budgets, source apportionment of deposition, and spatiotemporal patterns in deposition. The categorizations are for organizational purposes and the underlying topics may be relevant to multiple topic areas. The research topics are listed in Table 3.1 along with their

key knowledge gaps, which are framed in terms of research projects or foci that will produce data, tools, and knowledge which address the corresponding overarching policy-relevant science question. Thus, the policy-relevant science questions listed in Section 2.3 individually encompass multiple scientific research topics and their knowledge gaps. For example, consider the first policy-relevant question; “What research related to development of total Nr deposition budgets is needed to link atmospheric levels of Nr to ecosystem response?” This question is related to the development of the secondary NAAQS in which exposure is framed in terms of concentrations of species in air. The task is to follow those atmospheric levels of Nr species from the atmosphere through the deposition pathway, and to the exposure endpoint (i.e. uptake within the ecosystem). An example of a simplified “process-level” investigation would consider the physical and chemical processes of transport to the deposition surface, the characteristics of the deposition surface, any subsequent physical or chemical processing of that surface including potential re-emission, any means by which it is mobilized into an ecosystem, and in which ecosystem compartments it resides (e.g., leaf, soil).

In order to link the specific research topics to the policy-relevant science questions, the following series of broad science questions will be considered:

1. How much and what forms of nitrogen are deposited to terrestrial and aquatic ecosystems?
2. What are the relative fractions of wet versus dry deposition?
3. What are the most important processes by which gases and particles dry deposit to the landscape?
4. Are national monitoring networks sufficient to characterize the magnitude and important scales of variability of wet and dry deposition?
5. What methodological advances are needed to adequately speciate the atmospheric nitrogen budgets and to quantify air-surface exchange processes?
6. Do current landscape to regional scale models adequately simulate deposition processes?
7. What fraction of atmospherically deposited nitrogen is subject to regulatory control?
8. Are current methods for source apportionment of nitrogen deposition sufficient to support advancement of current regulations?

These science questions can begin to help categorize the specific knowledge gaps in the research topics and relate them back to the broader policy-relevant science question. We begin with the physical and chemical characteristics of the species in question, which is paramount in determining where and when the species will deposit. This suggests that science questions 1,2,3, and 5 need to be addressed to satisfy the policy-relevant science question. This example is summarized in Figure 3.1.

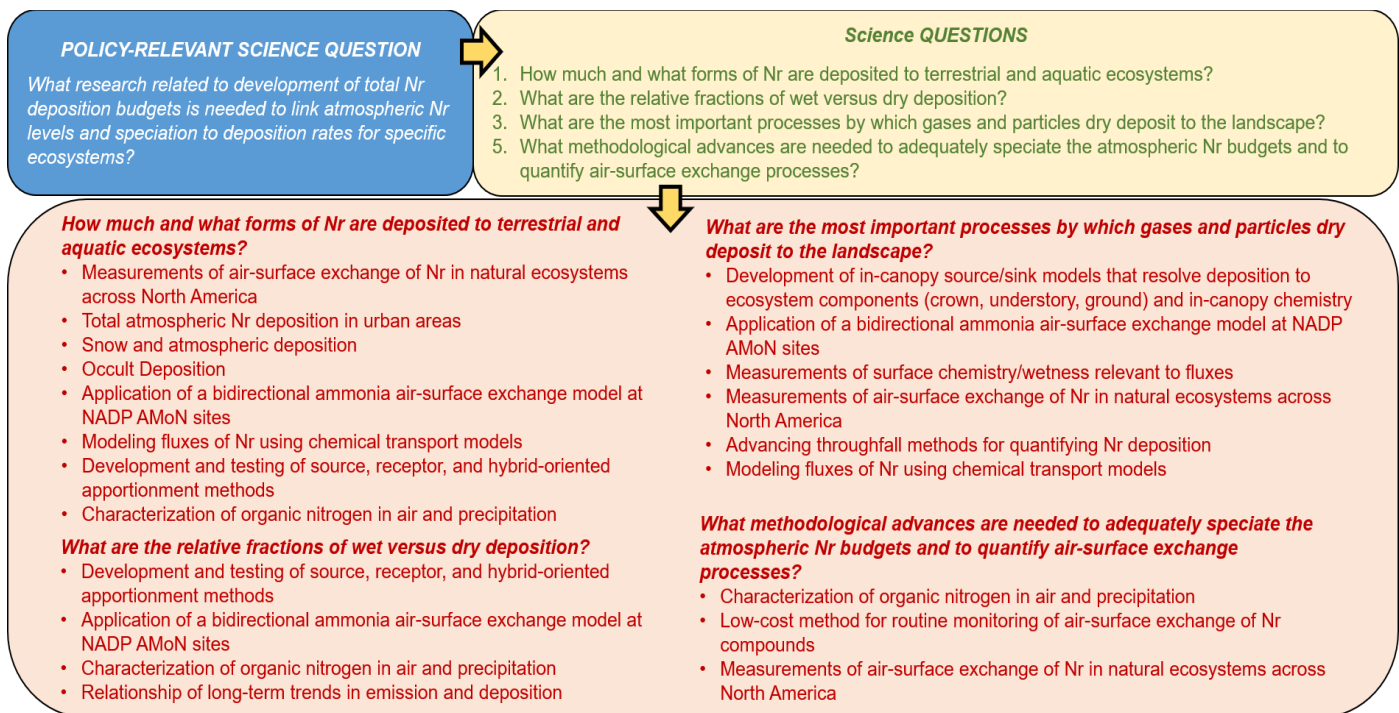

Figure 3.1. Example of relationship between a policy-relevant science question and its subsequent science questions and specific research topics.

At this level, we can begin to consider the very specific knowledge gaps that are identified for each research topic (Table 3.1). These knowledge gaps are identified and described in each research topic section where they have been prioritized and classified as “near-term” or “long-term” dependent on the level of effort and the current available technology as interpreted by the research topic authors.

The research topics presented in this document were selected by deliberation of the TDep committee and are not intended to represent an exhaustive list of focus areas of the field of Nr deposition, but are a starting list of research topics that the TDep committee has identified as important to advancing the state of the science. The sections on the research topics were developed by experts in their field or by consulting with experts in their field. While some degree of inter-topic variability and stylistic differences are inevitable, each topic contains a research topic summary, introduction, state of the science, and future research in an attempt to maintain consistency.

The “research topic summary” acts as an executive summary of the topic and includes the identified knowledge gaps in the field and summary of research needs discussed in the “future

research” section. The introduction will describe the background of the research topic. The “state of the science” section will expand on the introduction and identify any current or relevant research that has advanced or is advancing the current state of the science. The “future research” section will attempt to prioritize the key knowledge gaps and provide some specificity on potential paths forward. This could include an example of what a basic research study might entail, identify where potential collaboration opportunities might exist and indicate whether addressing the knowledge gap is a long-term or near-term endeavor.

List of Key Knowledge Gaps for Specific Research Topics

3.1. Measured total Nr deposition budgets

3.1.1. Process level measurements

3.1.1.1. *Measurements of air-surface exchange of Nr in natural ecosystems across North America*

Near-term:

- Develop a data base of existing flux measurement studies for model development and evaluation
- Develop a routine method for bulk organic nitrogen in precipitation
- Application of chemiluminescence/converter methods for speciated oxidized Nr and total reactive Nr flux measurements
- Deployment of low-costs time-integrated flux measurement techniques within existing monitoring infrastructure
- Assessment of dew volume and chemistry as supporting measurements for flux experiments
- Characterization of soil and vegetation chemistry to determine emission potentials as supporting measurements for NH₃ flux measurements
- Further development of open-path methods for direct measurement of NH₃ fluxes by eddy covariance
- Evaluation of the importance of NO₂ fluxes in high NO_x environments
- Application of online mass spectrometry for flux measurements of reduced forms of organic Nr, specifically amines and amides
- Assessment of surface resistance for HNO₃, alkyl and peroxy-nitrates

Long-term:

- Incorporating bulk ON into current routine monitoring infrastructure
- For oxidized organic Nr, separation of aerosol and gas phase contributions to the total oxidized organic Nr flux using coincident online aerosol and gas phase mass spectrometry methods
- Application of chemiluminescence/converter method for flux measurements of total alkyl and peroxy-nitrates
- Additional flux studies are needed in forest ecosystems, particularly deciduous forests, as well as high elevation and alpine environments, urban-to-rural gradients, agricultural regions, and coastal zones
- Assessment of effects of near-surface and in-canopy chemistry and reactivity on net air-surface exchange processes
- Measurements to elucidate the role of surface wetness and cuticle chemistry in the “non-stomatal” processes for gas phase HNO₃, NH₃, and peroxy-nitrates
- Measurements of N₂O₅ fluxes in coastal zones and downwind of urban areas
- Extension of micrometeorological flux measurement techniques to complex terrain typical of Nr sensitive high-elevation environments is also a long-term objective.
- Establishment of long-term sites for measurement of a core suite of reactive chemical fluxes including NO₂, total oxidized Nr, and total Nr
- Characterization of Nr deposition associated with “episodes” such as smoke plumes

3.1.1.2. *Measurements of surface chemistry and wetness relevant to fluxes*

Near-term:

- Apply measurements of dew volume to test surface moisture predictions in gridded chemical transport models such as CMAQ
- Use recent dew chemistry measurements to develop and test more representative parameterizations of cuticular resistance schemes.

Long-term:

- Expand current methods for assessing the volume and chemistry of surface wetness to include other chemical compounds
- Employing these methods to characterize a range of meteorological conditions, vegetation characteristics, atmospheric acidity, and atmospheric NH₃ concentrations
- Collocating this detailed surface wetness characterization with air-surface exchange measurements.
- Use dew chemistry measurements to develop and test more representative parameterizations of cuticular resistance schemes.

- Understanding the role of surface wetness in the deposition and re-emission of reactive nitrogen

3.1.1.3. Advancing throughfall methods for quantifying Nr deposition

Near-term:

- Assess collection efficiency and performance of throughfall measurements across canopy types and deposition regimes (wet versus dry proportions)
 - target different ecosystems and focus on spatial and temporal resolutions.
- Compile standardize database and implement standard methodologies for consistency and easier application of data.
- Increase the capacity of throughfall methods to relate to total Nr deposition, specifically to include stomatal uptake and deposition to canopy surfaces in both wet (precipitation and fog) and dry (gaseous and particulate) forms

Long-term:

- Expansion of IER methods to include other Nr compounds (organics),
- Development of methods for relating throughfall to deposition output from CTMs and in-canopy scale models.

3.1.1.4. Total atmospheric Nr deposition in urban areas

Near-term:

- Develop and deploy more passives (NH₃, NO_x) in large numbers to assess spatial variability (heterogeneity)
 - Expanding existing wet dep networks (e.g. NADP/NTN)
- Compile air-quality monitoring records for Nr species in urban air into a standardized data base for common research use (e.g. EPA CSN, IMPROVE, CASTNET)
- Conduct wet-&dry-sampling based on sub-categories of urban landscape paying particular attention to influential parameters such as population density, building height, tree or asphalt cover.

Long-term:

- development and expanded use of IER passive methods for sampling of bulk Nr deposition and throughfall in urban transects
- Investigate the relationship between atmospheric deposition and human population growth
- Conduct modeling studies to develop algorithms for urban deposition based on emission source terms and landscape characteristics and dynamics.
- Conduct studies of Nr in urban fog (occult deposition) and develop estimates of its relative importance to total deposition.
- Evaluate how structures (e.g. buildings) and urban forests affect estimation of total deposition variability in the urban environment.
- Improve modeling techniques to better define the radius of influence of urban emissions on surrounding areas.

3.1.1.5. Snow and atmospheric deposition

Near-term:

- Leverage resources for collaborative research sites to offset logistical challenges of remote and difficult terrain
- Improvements in monitoring technology and techniques to obtain more representative measurements of wet-deposition as snow
 - Improvement of NADP data validation, completeness criteria, and precipitation weighting of chemical concentration data at high elevation sites
 - Use of weekly bulk snow samples collocated with NADP sites to be used in cases when NADP samples are missed due to equipment failure.
 - Use of wind-shielded wet-deposition collectors to limit wind-blown secondary snow deposition
 - Use of independent precipitation gages not impacted by wind-redistributed snow to correct snow-deposition measurements.
- Use of bulk measurement methods to characterize spatial variability and deposition processes
 - IER throughfall/bulk deposition collectors to augment summer deposition measurements
 - Snowpack measurements to augment winter total deposition measurements.
 - Passive sampler methods to characterize spatial variability of air concentrations to inform dry deposition estimates
 - Measurements of bulk snow surface minus NTN weekly concentration differences to estimate dry deposition
 - Lysimeters to characterize the Nr content, transformations, and subsurface movement of the snowpack during melting
- Prioritization of dry deposition model improvements considering impact on deposition totals and simplicity and cost of sampling

Long-term:

- Implementation of consistent and standardized routine deposition measurement methods at alpine sites
- Intensive detailed measurements to examine processes and improve deposition models
 - Measurements of rime ice
 - Direct flux measurements to quantify dry deposition and re-emission from the snow surface
 - Coupled air-surface flux and snow measurements to quantify surface resistances to deposition and the roles of surface wetness and chemistry

3.1.1.6. Occult deposition: what we know, don't know, and should really know

Near-term:

- Outreach to fog and cloudwater communities to pursue consolidation of historic research (e.g. a review paper) and standardized datasets
- Analyze existing data to answer needed research questions (i.e. How much are existing datasets influenced by trends in background and long-range transport signals?)
- Collect data in different environments to improve spatial variability of estimates for total Nr or wet/dry fractions.

Long-term:

- Develop standardized and comparable sampling methods.
- Framework of current National monitoring networks is insufficient for mountain-top sampling, evaluate the feasibility of sampling in coastal or other fog prone areas.
- Characterizing process-level information empirically, so that it may be incorporated into parameters of CTMs.

3.1.2. Routine monitoring

3.1.2.1. Wet deposition annual precipitation-weighted mean concentrations from incomplete time series: Influence of completeness criteria, data validation, and data substitution methods

Near-term:

- Base network completion criterion on scientific consensus and experimental evidence rather than exclusive best-management practices
 - Evaluation of the definition of contaminated samples
 - Identifying valid data with systematic biases
 - Evaluation of differences in frequencies and types of sample invalidation among different wet-only collectors (i.e. Aerochem versus N-CON versus MIC-type collectors).
- Statistical treatment of missing or incomplete data (e.g. using nearby measurements to substitute for missing values)
 - Evaluate potential alternative methods (e.g. precipitation weighting, data completeness) for impacts on modeled results (e.g. TDep spatial variability)
- Comparison of reliability and functionality of optical precipitation sensors that can operate in remote areas on battery/solar power to improve precipitation collection

Long-term:

- Sampling improvements
 - Collection of more representative samples (wind shields, bird-proof, debris exclusion, operator training, real-time monitoring)
 - Back up samplers to reduce incomplete sampling intervals (e.g. backup bulk snow collectors)
 - Evaluate special protocols for monitoring extreme events and adverse weather conditions, especially for high-altitude and coastal sites

3.1.2.2. Satellite measurements of oxidized and reduced nitrogen for application to Nr budgets

Near-term:

- Continued incorporation of satellite-derived tropospheric-level VCDs into surface measurement-chemical transport model fusion tools to pursue existing research problems associated with the total Nr deposition budget.
 - Evaluation of spatial variations with surface measurements and land-use types to improve extrapolation techniques in hybrid deposition mapping approaches
 - Better understanding of synoptic-scale atmospheric chemical processes and pollution transport
 - Reversible processes of bidirectional deposition and particle formations
 - Effects of meteorology and other compounds
 - Use of measurable species as surrogates for non-measured species
 - Characterize the variability and uncertainty of emissions inventories for measured and non-measured point sources, area sources, and episodic events.
- Active participation of deposition scientists and ecologists in existing committees dedicated to connect users to available satellite data products (e.g. HA-QAST)

Long-term:

- Improved technologies (instrument sensitivities, geostationary orbits, and retrieval methods) to improve the overall quality of data products will increase the spatial and temporal resolution thereby decreasing needed averaging times and increasing applicability for research on Nr deposition.
- Better characterization of vertical profiles from surface stations
- Evaluation of variability and uncertainty of the retrieved satellite data product over a wide range of atmospheric conditions.

3.1.2.3. Linking of air concentrations to deposition via transference ratios

Near-term:

- Characterizing the relative uncertainty and sensitivity of transference ratios over:
 - Spatial and temporal scales and across different modeling platforms.

Long-term:

- Development of new “structures” for NH_x and fitting that framework to couple with available observations.

3.1.2.4. Low-cost method for routine monitoring of air-surface exchange of Nr compounds

Near-term:

- Further evaluation of method over short vegetation
 - Assessment of precision and accuracy of flow system and chemical measurements
 - Determination of optimal sampling duration and gradient configuration
 - Assessment of uncertainty and bias due to conditional sampling (e.g., “missing” flux)
 - Assessment of contribution of uncertainty in chemical measurements and conditional sampling to total uncertainty
 - Comparison to direct flux measurement technique
- Assess existing datasets of atmospheric chemistry and micrometeorology to investigate potential sites for deployment into existing national monitoring infrastructure
- Investigate variable flow rates to assess applicability to wider range of sampling environments

Long-term:

- Expand denuder/filter pack method to full suite of Nr compounds (e.g. particulate ON, total ON, total Nr)
- Evaluation of method over tall vegetation
- Deployment into select sites within existing national monitoring infrastructure

3.1.2.5. Characterization of organic nitrogen in air and precipitation

Near-term:

- Collaboration between the modeling and monitoring communities to identify and prioritize the largest sources of uncertainty in modeled ON estimates given the available measurement technologies.
- Development and testing of new analytical and measurement techniques to make more routine measurements or monitoring feasible
- Incorporate ON measurements into planned field programs investigating the impacts of biomass burning on atmospheric chemistry

Long-term:

- Standardization of ON measurement techniques to amass comparable data for ON to better determine speciation, trends and variability, characterization of sources, deposition processes and relative importance in the atmosphere and in ecosystems
- Examine tradeoffs in data coverage versus cost and complexity between real-time versus time-integrated measurements
- Incorporating bulk ON into current routine monitoring infrastructure

3.2. Modeled total Nr deposition budgets

3.2.1. Application of a bidirectional ammonia air-surface exchange model at NADP AMoN sites

Near-term:

- Development of a methodology for applying time-integrated AMoN NH₃ measurements to the bidirectional modeling framework
- Further evaluation of the bidirectional flux model against direct flux measurements in natural ecosystems
- Evaluation of methods for determining soil compensation points in natural and agricultural soils
- Evaluation of the importance of leaf litter as a source of NH₃ in natural ecosystems

Long-term:

- Development of a database of species-level stomatal emission potentials for natural vegetation across North America
- Development of a database of soil and leaf litter emission potentials for natural ecosystems across North America
- Incorporation of exchange pathway for wet surfaces into the bidirectional flux framework
- Improvement of the dry cuticular resistance within the bidirectional flux framework
- Expansion of AMoN to existing ecological observation networks to leverage data sets for NH₃ flux modeling

3.2.2. Development of in-canopy source/sink models that resolve deposition to ecosystem components (crown, understory, ground) and in-canopy chemistry

Long-term:

- Legacy models of vegetative canopies that were developed decades ago need to be updated to reflect the sophistication of modern scientific understanding, measurement techniques, and computational methods.
 - Incorporation of aerosols
 - Bidirectionality of biogenic hydrocarbons
 - Biologically-based representations of processes rather than empirical parameterizations (e.g. biogenic emissions)
 - Intermittency of canopy-atmosphere exchange
 - Within-canopy chemical and phase transitions
 - Parameterizations appropriate for finer grid-resolutions
- Advancement of these models will require:
 - Intermodal comparisons and evaluation
 - Dedicated field-measurement campaigns for model development and validation.
- Incorporation into large-scale CTMs will require downscaling and computational streamlining

3.2.3. Modeling fluxes of Nr using chemical transport models

Near-term:

- Improvement of inventories of mobile-source NO_x emissions inventory
- Improved understanding of the fate of organic nitrates and the parameters that drive N₂O₅ reactions
- Improved representation of cation chemistry in aerosol equilibrium models to improve phase partitioning
- Expanded measurements to improve the understanding of non-stomatal exchange processes in different conditions and reduce the need for empirical parameterization in models
- Database of NH₃ emission potentials for range of North American vegetation and soil types
- Field studies to improve understanding of surface-atmosphere exchanges of accumulation mode (0.1 - 2 μm) particles
- Model intercomparison studies to characterize uncertainty and variability of modeled deposition values and inform priorities for process-level measurements and monitoring

Long-term:

- Reducing uncertainties in NH₃ emissions inventories
 - Facility-scale inventories for confined animal feeding operations
 - Studies to evaluate EPIC NH₃ emission potentials against soil biogeochemical Nr measurements and NH₃ fluxes for different ranges of soil and fertilizer types, application methods, and meteorological conditions
- Intensive field studies that characterize the effects of in- and near-canopy chemistry on net fluxes including measurement of NO_y, NH_x, and relevant BVOC chemistry budgets
- Long-term flux measurement studies
- Improved understanding of emissions, atmospheric chemistry, and air-surface exchange processes of amines

3.2.4. Assessing uncertainty in total Nr deposition estimates for North American critical load applications

Near-term:

- Engagement with critical loads community to identify most useful metrics of uncertainty for exceedance assessments
- Compilation of databases of non-network deposition measurements (e.g., throughfall, canopy-scale flux studies) for model development and evaluation
- Comparison of outputs from chemical transport models and model ensembles (CMAQ, CAMx, GEM-MACH) currently used for North American deposition assessments (e.g. AQMEII-4)
 - Assess the components (e.g. MET, surface roughness heights) of chemical transport models that contribute the most to deposition uncertainty
- Geographical expansion of lichen sampling to improve biomonitoring deposition models
- Comparison of total deposition estimates from ADAGIO and TDep hybrid measurement-model fusion methods
- Expansion of measurement-model fusion methods to include more networks (e.g. IMPROVE) and 'out of network' measurements
- Analysis of sub-grid (land use specific) variability in deposition using CMAQ MOSAIC

Long-term:

- Further development of methods to incorporate satellite data into measurement-model fusion approaches
- Improvement of CTM chemistry and air-surface exchange:
 - Adoption of methods within CTMs to output land use specific deposition velocities and fluxes for ecological applications
 - Improvement of dry deposition algorithms in CTMs
 - Parameterizations of non-stomatal exchange pathways
 - Consideration of the influence of in- and near-canopy chemistry on net exchange fluxes (e.g. forests)
 - Improved treatment of organic Nr
- Development of deposition uncertainty maps for critical loads applications
 - Development of methods for mapping land use specific deposition velocities and fluxes and bias correction of bidirectionally exchanged compounds in MMF procedure
- Establishment of long-term sites for process-level and routine reactive chemical flux measurement across different ecosystems and deposition regimes for developing models and calibrating throughfall measurements
- incorporating bulk ON into current routine monitoring infrastructure

3.3. Source contributions to total Nr deposition

3.3.1. Development and testing of source, receptor, and hybrid-oriented apportionment methods

Long-term:

- Improving base model performance through improvements in input data and process parameterizations
- Incorporation of the state of the science of chemical and physical atmospheric processes into source apportionment modules
- Development and improvement of methods to capture uncertainty associated with source apportionment modeling

3.3.2. Isotopic advances in understanding Nr deposition

Near-term:

- Research on characterizing isotopic Nr signatures from emission sources
 - More robust inventory of emission source signature for NO_x and NH₃ emission sources
 - Observations that focus on mechanisms driving variations in source signatures
- Research to characterize isotope effects (i.e. fractionations) that can occur in the atmosphere that can alter the fidelity of isotopic source signatures and the composition of Nr

- Laboratory and field studies to address the effects of field conditions, geographic scale, and atmospheric processes on resulting isotopic compositions of Nr deposition
 - Gradient studies, microscale to national-scale, employing Nr sampling, back trajectory analyses, mixing models, fractionation factors
 - Application of $\Delta^{17}\text{O}-\text{NO}_3^-$ to understand the impact of atmospheric NO_3^- deposition on ecosystems
 - Resolving potential funding venues for atmospheric deposition research within the atmospheric chemistry discipline
- Long-term:**
- Coupling of isotopic information with CTMs for analysis of chemistry and deposition processes, validation of emissions, and source tracking.

3.4 Spatial and temporal patterns of total Nr deposition

3.4.1. Relationship of long-term Nr trends in emission and deposition

Near-term:

- Assessment of past regional and national studies on linkages between emissions and ambient monitoring data for Nr species
 - Understand how EGU pollution control reductions and subsequent emissions have impacted monitoring trends of Nr and deposition
 - Understand how local pollution controls can impact regional ambient Nr monitoring trends
- Existing measurements could be used to evaluate biases in deposition models that can impact long-term trends
- Explore methods (e.g. gridded bias surface corrections) to preserve consistency of modern deposition estimates with past estimates as methods improve

Long-term:

- More robust emissions inventories for NH_x sources, organic nitrogen (ON) compounds, and non-EGU sources
- Current monitoring networks need to incorporate new sampling strategies to address lack of spatially and temporally resolved Nr measurements
 - Routine measurements of ON (in precipitation and in the ambient atmosphere)
 - Increased deployment in urban, coastal, and agricultural areas
 - Addition of passive NO_2 samplers to NADP AMoN network
 - Incorporate satellite measurements
 - Long-term measurements of direct dry deposition
 - Speciated measurements of oxidized nitrogen

3.4.2. Spatial variability of ammonia in agricultural regions

Near-term:

- Expand AMoN network in agricultural areas (especially those with significant spatial gradients)
- Conduct small-scale, localized concentration studies near large agricultural emissions sources.
 - High spatial density deployment of integrated NH_3 passive monitors to capture sharp concentration gradients in combination with one or two high-time resolution sites to capture diurnal patterns.
- Improve communication between modelers and field scientists on how existing and future datasets will be used in modeling applications.
 - Data on animal operations could be used to constrain the radius of influence around a monitoring site for locations influenced by large NH_3 emissions sources
 - Specific field results could be added to emissions inventories to better characterize predicted radius of influence
 - Exchange of information on key biases and uncertainties and how studies can be run to address these

Long-term:

- Characterize NH_3 spatial variabilities by type of emission facility (e.g. crop-production vs. animal husbandry), facility management activities (e.g. manure turning, fertilizer spreading), distances from the source, and density of surrounding operations (e.g. cattle-head counts)
- Increase robustness of emission inventories (spatially resolved and operation-specific)
 - Chemical transport models need to be able to capture CAFO locations, sizes, and seasonal changes to characterize the variability between NH_3 monitoring sites. Model results can then be bias-corrected using measurements where they are available.
 - Development of a facility scale emissions inventory for CAFOs is needed, which will require collaboration with industry stakeholders, USDA and other Federal agencies, as well as academic institutions
 - For emissions from fertilized soils, additional studies are needed to evaluate EPIC NH_3 emission potentials against soil biogeochemical Nr measurements and NH_3 fluxes for a wider range of soil and fertilizer types, including increased Nr efficiency formulas, application methods, and soil types

Table 3.1. Summary of research topics and knowledge gaps.

3.1. Measured Total Nr Deposition Budgets

The field of measuring Nr deposition budgets is categorized here in two different sub-sections. The first, “process-level measurements”, represent measurements and studies that have a more “ground-up approach” to measure and understand the physical phenomena inherent in air-surface exchange processes to aid modelers in developing accurate and data-driven deposition algorithms and modeling approaches. The second category, “routine monitoring”, is more of a “top-down approach” to acquire large amounts of air concentration and deposition data in a standardized and large scale manner that is characteristic of a monitoring network. These Nr measurements need to be performed easily and cheaply to understand the patterns of Nr deposition on a regional scale and are incorporated into modeling approaches to “calibrate” or evaluate model results with real-world observations. Both of these approaches have specialized measurement methods and techniques of varying degrees of maturity, which are discussed in detail in the respective research topics.

3.1.1. Process-Level Measurements

Process-level measurements attempt to quantify and characterize the fundamental chemical, physical, and biological processes affecting deposition. Depending on the unknown parameter, approaches can range from sophisticated high-time resolution techniques for direct flux measurements to the expansion of more low-technology sampling methods in different ecosystems or remote environments that are not yet well-characterized (e.g. cloud water sampling, within canopy forest deposition sampling, high-elevation snow surface sampling). The research topics chosen for this area include research for improving the current understanding of dry deposition processes as discussed in section **3.1.1.1. Measurements of air surface exchange of Nr in natural ecosystems across North America**. This section looks closer into the application of high-time resolution methods for the direct measurement of deposition fluxes and expanding those direct measurement techniques to characterize fluxes for different nitrogen species in both oxidized and reduced forms. For example, a major uncertainty in understanding the deposition flux process is the role of the surface chemistry that occurs with wetness on surfaces. Section **3.1.1.2. Measurements of surface chemistry/wetness relevant to fluxes** describes the role that dew can play in the deposition fluxes of both gas and aerosol phases for different species, especially with diurnal patterns of formation and evaporation.

Most regional deposition monitoring in the U.S. is done in open-field sites in rural areas. Sampling within forested areas is limited. Methods to expand monitoring within forested canopies and to integrate that data into regional deposition estimates is discussed in section **3.1.1.3. Advancing throughfall methods for quantifying Nr deposition**. Similarly, there are limited measurements of deposition made in urban areas, owing to the difficulties in sampling logistics and highly variable concentrations and micrometeorology. These issues are discussed in **3.1.1.4. Total atmospheric Nr deposition in urban areas**. Pollutants will deposit to snow surfaces via differing processes in snowy or alpine environments, there is interest in better understanding these processes as many of these areas are particularly sensitive ecosystems.

These processes are discussed in **3.1.1.5. *Snow and atmospheric deposition***. Most current deposition monitoring and modeling is limited in terms of occult deposition. In many areas (e.g. high elevation, coastal areas), this can be an important deposition pathway as discussed in **3.1.1.6. *Occult deposition: what we know, don't know, and should really know***.

3.1.1.1. Measurements of air-surface exchange of Nr in natural ecosystems across North America

John T. Walker¹, Gregory M. Beachley², Katherine B. Benedict³, Barkley C. Sive⁴, Donna B. Schwede¹

¹U.S. EPA, Office of Research and Development, Durham, NC

²U.S. EPA, Office of Air Programs, Washington, DC

³Colorado State University, Department of Atmospheric Science, Fort Collins, CO

⁴National Park Service, Air Resources Division, Denver, CO

Research topic summary

Total Nr deposition budgets rely heavily on estimates of speciated fluxes derived from site specific inferential models, gridded chemical transport models, and hybrid approaches that fuse measurements and models. Direct flux measurements are needed to develop more complete and accurate budgets of Nr deposition in sensitive ecosystems and to improve deposition models.

This section summarizes the state of the science of measurements of dry deposition of Nr compounds, beginning with a review of the current understanding of the importance of dry deposition to total deposition at the continental scale, followed by a review of the micrometeorological and analytical methods used for direct measurements of air-surface exchange, and then summarizing the existing measurements of Nr air-surface exchange measurements in natural ecosystems in North America. The data and knowledge gaps summarized below motivate research needed to address the incompleteness of dry deposition budgets, more fully characterize temporal and geographical variability of fluxes, and better understand air-surface exchange processes to improve models used for deposition assessments.

With respect to the completeness of deposition budgets, the contribution of organic Nr dry deposition is unknown. For reduced Nr species, techniques which allow for direct measurement of the total reduced Nr flux represent an important first step in accounting for this component of the dry deposition budget and could be implemented in the near term. Further development of analytical techniques for separating gas phase and particulate organic nitrate fluxes and for directly measuring fluxes of amines represent high priority longer term efforts.

Better characterization of the spatial and temporal patterns of dry deposition is needed. Establishment of long-term sites for process level measurements of reactive chemical fluxes is an important long-term endeavor of the atmospheric chemistry and ecological communities. This effort could be complemented in the shorter term by deployment of low-cost time-integrated flux measurement techniques within existing network infrastructures. Additional flux

measurements are needed in forest ecosystems, particularly deciduous forests. Other specific geographical gaps where measurements are needed over the long term include high elevation and alpine environments, urban-to-rural gradients, agricultural regions, arid ecosystems, and coastal zones. Characterization of Nr deposition associated with smoke plumes (e.g., wildfire) is a high priority but likely a longer-term, opportunistic effort.

From a process standpoint, establishment of a publicly available metadatabase for Nr flux measurements in the near term would serve the atmospheric science and ecological communities interested in better understanding the processes and drivers of land-atmosphere exchange of Nr and development of models to better simulate these processes. Measurements of particulate and gas phase oxidized Nr fluxes point to the need for studies to quantify within- and near-canopy sources and sinks of the components of the chemical system under study (e.g., NO_y or HNO₃-NH₃-NH₄NO₃) such that models can be advanced to incorporate underlying biological, chemical, and physical processes. Surface wetness and chemistry to elucidate the role of surface wetness and cuticle chemistry in the canopy resistances for gas phase HNO₃, NH₃, and peroxyacyl nitrates (PAN) species and biogeochemistry to parameterize NH₃ emission potentials are high priority process measurements that could be incorporated into flux experiments in the near term.

Regarding technological advances, development of open-path techniques for NH₃ flux measurements and application of online mass spectrometry for flux measurements of reduced forms of organic Nr, specifically amines, could be accomplished in the relatively near term. Extension of micrometeorological flux measurement techniques to complex terrain typical of Nr sensitive high-elevation environments is a long-term objective.

This review highlights the need for closer collaboration between the atmospheric chemistry and ecological communities with respect to advancement of Nr deposition budgets in North America. The NADP TDep community could engage with atmospheric chemistry studies more directly where possible to advocate for science objectives that integrate atmospheric chemistry and ecological questions relevant to Nr deposition.

Introduction

Direct measurements of Nr fluxes are urgently needed to develop fully speciated total Nr deposition budgets and to improve air-surface exchange algorithms used in soil-vegetation-atmosphere models. Routine monitoring of wet and dry deposition in the U.S. does not capture the full budget of reactive nitrogen. For example, while the spatial coverage of wet deposition across the NADP network is extensive, only inorganic forms of Nr are measured. Organic forms of Nr, which contribute ~ 25% of Nr in precipitation on a global scale (Jickells et al., 2013) are not routinely measured under NADP due to difficulties in preserving samples both in the field and laboratory (Walker et al., 2012). For dry Nr deposition, the Clean Air Status and Trends Network (CASTNET) provides estimates of HNO₃, NH₄⁺ and NO₃⁻ dry deposition fluxes derived from concentration measurements applied to modeled deposition velocities (Bowker et al.,

2011). CASTNET does not monitor NH₃ or organic forms of nitrogen. The NADP AMon network provides two-week integrated measurements of NH₃ at approximately 100 sites across the U.S. Methods for application of AMon measurements to dry deposition modeling are under development. Thus, routine monitoring in the U.S. does not currently provide wet or dry estimates of organic Nr or dry deposition estimates of NH₃, which are estimated to contribute significantly to total Nr deposition (Jickells et al., 2013; Schwede and Lear, 2014). Until these components of the Nr deposition budget are routinely measured, flux measurement studies are needed to provide total deposition budgets by which to assess critical load exceedances and to quantify the fraction of Nr deposition subject to regulatory control.

Direct flux measurements and associated measurements of surface chemical, physical, and biological characteristics are urgently needed to improve air-surface exchange algorithms used in field scale deposition modeling as well as gridded chemical transport models (CTMs). Measurements are particularly needed for NH₃ and gas phase organic Nr compounds (e.g., PANs). Improvement of dry deposition and bidirectional air-surface exchange algorithms relies on technological advances in analytical methods suitable for flux measurements of the important Nr compounds and their application across a range of atmospheric conditions and ecosystem types to develop datasets of sufficient process-level detail for improvement and rigorous evaluation of soil-vegetation-atmosphere transfer models.

Recent assessments in Europe (Flechar et al., 2011) and the U.S. (Li et al., 2016) show that commonly used field-scale inferential models may differ by a factor of 3 or more. Canopy resistances used in deposition schemes in chemical transport models can also exhibit relatively large differences across models (Wu et al., 2011), leading to large differences in deposition estimates. Adoption of a bidirectional flux framework for NH₃, which is now common in CTMs, requires the use of compensation point parameterizations (e.g., soil and vegetation emission potentials) that remain poorly characterized for many ecosystems, leading to large uncertainty in NH₃ dry deposition rates at the local scale (Dennis et al., 2013). Parameterization of emission potentials and surface resistances for NH₃ are largely derived from European experiments (Massad et al., 2010; Zhang et al., 2010) and their applicability to North American ecosystems remains an open question. Additionally, spatial variability of NH₃ concentrations, particularly in agricultural areas, results in large uncertainty in NH₃ concentrations at the model sub-grid scale, imparting additional uncertainty to NH₃ dry deposition estimates (Schwede and Lear, 2014).

This section summarizes the state of the science of measurements of dry deposition of Nr compounds in North America, beginning with a review of the current understanding of the importance of dry deposition to total deposition at the continental scale, followed by a review of the micrometeorological and analytical methods used for direct measurements of air-surface exchange, and then summarizing the existing measurements of Nr air-surface exchange measurements in natural terrestrial ecosystems. We then identify examples of long- and short-term research needed to address data gaps from the perspective of developing more complete deposition budgets and improving current understanding of air-surface exchange processes.

We acknowledge that because the scope of this review is constrained to North America, the large body of Nr flux work performed in Europe and elsewhere, which established the basis for much of the work in the U.S., particularly for NH₃, is not covered in detail.

State of the science

Deposition budget

To provide context for the discussion of dry deposition in the following sections, the total and dry components of the deposition budget for 2015 for the continental U.S. are shown in Figure 1. The budget was developed using version 5.2.1 of the Community Multi-scale Air Quality Model (CMAQ, www.epa.gov/CMAQ). The depositing species are categorized by wet or dry deposition, and oxidized (labeled with 'OXN') versus reduced (labeled with 'REDN') forms of nitrogen. OXN_NOX includes NO and NO₂; OXN_PANT represents total peroxy nitrates (PNs) in the gas phase; OXN_ORGN represents other gas phase organic Nr species such as isoprene nitrates; OXN_OTHR represents nitrogen pentoxide (N₂O₅) and nitrous acid (HONO); NO₃ and NH₄ represent particulate components; TNO₃ represents total gaseous HNO₃ + particulate NO₃⁻; and REDN_TOT represents total gaseous NH₃ + particulate NH₄⁺. Relevant to the total budget, it is important to note that reduced forms of organic Nr are not considered in either the dry or wet components, nor is the treatment of oxidized organic Nr comprehensive. Thus, from a completeness standpoint the budget will be biased low. With this caveat, the budgets shown in Figure 1 reflect the state of the science of deposition modeling as represented by a widely used regional CTM and, as such, are used here to illustrate the relative importance of the dry deposited fraction of Nr and the contribution of individual species or groups of compounds to the dry deposition budget. Nr deposition budgets have been previously developed for the U.S. and Canada using other versions of CTMs (Dennis et al., 2013; Zhang et al., 2012a) and combinations of measurements and inferential modeling (Zhang et al., 2009).

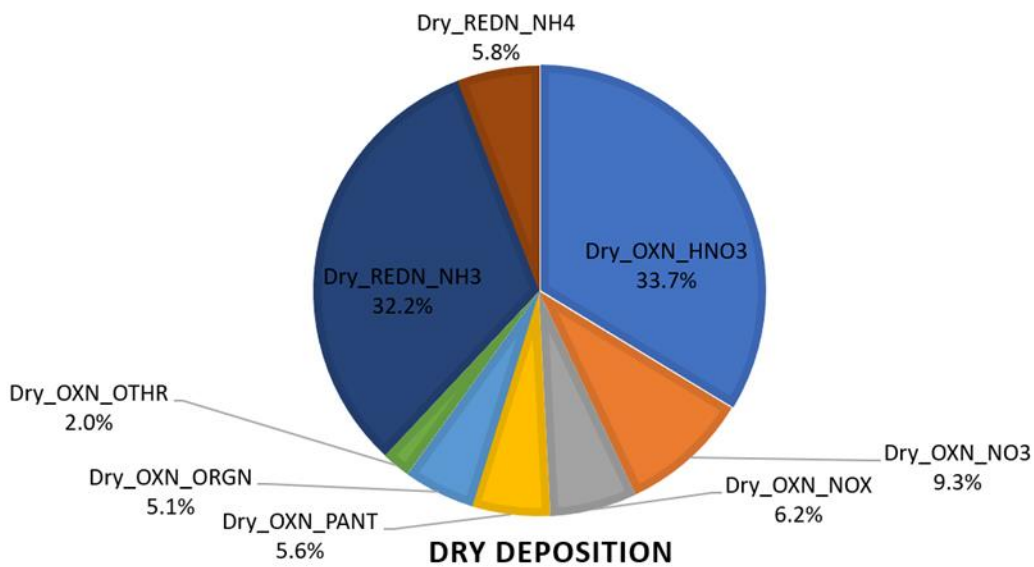
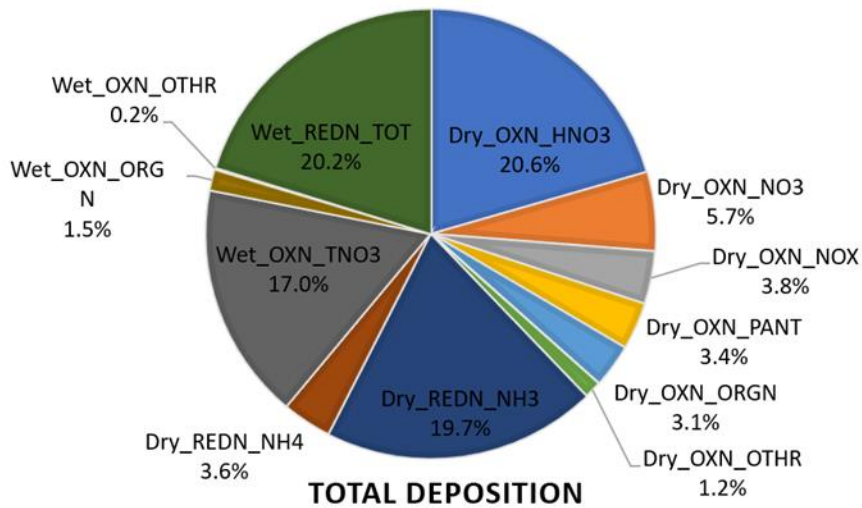

Figure 1. Reactive Nr deposition budget for the continental U.S. developed using CMAQ V5.2.1. The upper pie is the Total Nr budget, the lower pie is dry deposition only. The depositing species are categorized by wet versus dry deposition, and oxidized (OXN) versus reduced (REDN) forms of nitrogen.

The CMAQ simulation summarized in Figure 1 shows that dry deposition dominates the Nr budget at the continental scale, contributing 61% of total deposition compared to 39% from wet deposition. Due to the uncertainties as noted in the Introduction, the dry deposition

component of the budget is much more uncertain than the wet component, further emphasizing the need for additional data and improved modeling algorithms for dry deposition (Wu et al., 2011; Flechard et al., 2011; Li et al., 2016). The reader is referred to Section **3.2.3. Modeling fluxes of reactive nitrogen using chemical transport models** and Section **3.2.4. Assessing uncertainty in total Nr deposition estimates for North American critical load applications** for a detailed discussion of key uncertainties and knowledge gaps related to modeling of gas and aerosol dry deposition of Nr species. Oxidized and reduced forms of nitrogen account for 57% and 43% of total N deposition and 62% and 38% of dry deposition, respectively. The primary forms of dry deposition are HNO₃ (33.7%) and NH₃ (32.2%), which together account for approximately 2/3 of dry N deposition. We note that in this simulation NH₃ fluxes are modeled using a bidirectional flux framework (Pleim et al., 2013; Bash et al., 2013). Deposition of NO₃⁻ aerosol (OXN_NO₃) contributes 9.3% of dry deposition. OXN_NOX, which due to atmospheric processing is essentially all NO₂, contributes 6.2% of the dry budget, followed in importance by dry deposition of NH₄⁺ aerosol (5.8%). Dry deposition of gas phase organics (OXN_PANT = 5.6%; OXN_ORG = 5.1%) together account for 10.7% of the dry budget while OXN_OTHR (N₂O₅ and HONO) contribute 2.0%.

Flux measurement methods

Micrometeorological methods for direct measurement of Nr air-surface exchange include eddy covariance, gradient methods, and relaxed eddy accumulation (Baldocchi et al., 1988).

Eddy covariance

The most direct approach to quantifying air surface exchange is the eddy covariance technique (EC), in which the vertical flux (F) of mass or heat through a horizontal plane in the atmosphere, such as above a forest canopy, is the covariance of the fluctuating components of the vertical wind velocity (w) and the scalar of interest, which in this case is the concentration of the chemical species of interest (c), represented in equation (1) as:

$$F = \overline{w'c'} \quad (1)$$

where the overbar represents time-averaging, usually 30 minutes, and the primes represent deviations from the mean, illustrated in equation (2).

$$c' = c - \bar{c} \quad (2)$$

The primary requirements for standard EC (e.g., ignoring advection and storage) are flat, homogeneous terrain over a sufficient area surrounding the measurement location, typically 100 m horizontal fetch for every 1 m of sensor height above the surface, well-developed turbulence, and chemical and meteorological instruments of sufficient time response and precision to capture the range of eddy motions driving the air surface exchange. Time response requirements are typically between 1 and 10 measurements per second depending on the surface and corresponding sensor height.

Gradient methods

Gradient approaches involve measuring the vertical concentration profile at two or more heights above the exchange surface and applying the measured vertical concentration gradient to the measured eddy diffusivity for momentum, heat, or mass. The typical calculation (e.g., Thomas et al., 2009) for the vertical flux (F) of chemical species X is an adaptation from Thom (1975):

$$F_x = -C_* u_* \quad (3)$$

where u_* is friction velocity, calculated from the momentum flux measured EC, and C_* is the concentration scale calculated as:

$$C_* = \frac{k}{\ln\left(\frac{z_2 - d}{z_1 - d}\right) - \psi_H\left(\frac{z_2 - d}{L}\right) + \psi_H\left(\frac{z_1 - d}{L}\right)} \cdot \Delta C \quad (4)$$

Here ψ_H is the integrated stability function for sensible heat (Thom, 1975), z_1 and z_2 are the measurement heights above ground between which the concentration gradient (ΔC) is measured, L is the Monin-Obukhov length calculated from the EC derived sensible heat flux, k is the von Karman constant ($k = 0.41$), and d is the zero plane displacement height. A variant of this method is the modified Bowen-ratio (MBR) (Meyers et al., 1998) in which the turbulent diffusivity is assumed to be similar to the turbulent diffusivity for heat such that the flux may be calculated as:

$$F_x = \overline{w'T'} \frac{\Delta C}{\Delta T} \quad (5)$$

$\overline{w'T'}$ is the kinematic heat flux measured by EC, and $\Delta \overline{C}$ and $\Delta \overline{T}$ are co-located mean concentration and air temperature differences between heights z_1 and z_2 above the canopy. The ratio of the heat flux to the temperature gradient is also known as the eddy diffusivity for heat (K_h). Gradient methods also require flat, homogeneous terrain and well-developed turbulence. Drawbacks relative to EC include the need to correct profiles for atmospheric stability (aerodynamic method), the increased uncertainty during transition periods when heat fluxes (or other scalars on which the eddy diffusivity is based) become small (MBR method), and the need to correct for effects of sampling within the roughness sublayer in the case of tall vegetation. The advantage to gradient methods relative to EC is that they can be employed to measure fluxes of compounds for which fast sensors are not available. Fluxes are typically determined from gradients of concentrations integrated over 30 minutes to an hour.

Relaxed eddy accumulation

Relaxed eddy accumulation (REA) is an alternative technique that allows for measurement of the flux at a single height but without the > 1 Hz sampling requirement of eddy covariance

(Businger and Oncley, 1990). Measurement of the flux at a single height avoids the need for stability corrections and uncertainty in flux footprint estimation associated with gradient techniques. The REA approach employs fast switching based on measurement of the vertical wind speed to sample air concentrations in upward versus downward moving eddies, over averaging periods up to a few hours, from which the flux is determined as:

$$F_x = \beta \sigma_w (X \uparrow - X \downarrow) \quad (6)$$

$X \uparrow$ and $X \downarrow$ are the average air concentrations in the up- and down-drafts, respectively, σ_w is the standard deviation of the vertical wind velocity (measured at 10 Hz), and β is an empirical dimensionless parameter that can be estimated from EC measurements of temperature and other scalars (Katul et al., 1996). REA systems can employ continuous or time-integrated measurements of atmospheric concentrations, with averaging periods from 30 minutes to 4 hours.

Flux datasets

Published datasets of Nr micrometeorological flux measurements for natural ecosystems in North America are summarized in Table 1. Data are categorized by flux measurement method and analytical (e.g., online measurements) or sampling methods (e.g., time integrated approaches) are also indicated. Our review is limited to studies employing micrometeorological flux measurement techniques and focusses on studies in the U.S. and Canada. Earlier flux measurements conducted in North America and elsewhere have been previously summarized by Zhang et al. (2002).

Table 1. Published datasets of Nr micrometeorological flux measurements for natural ecosystems in North America

Phase	Nr compounds	Flux Technique		
		Eddy Covariance	Gradient	REA
<i>Oxidized inorganic Nr</i>				
<i>Gas</i>	NO _x (NO+NO ₂)	CL, Wolfe et al., 2015. CL, Geddes et al., 2014; CL, TD-LIF, Min et al., 2014; TD-LIF, Farmer et al., 2006; CL, TD-LAS, Horii et al., 2004; Delaney et al., 1986	N/A	N/A
	HNO ₃	CIMS, Nguyen et al., 2015; TD-LIF, Min et al, 2014; TD-LIF, Farmer et al, 2006; TD-LAS, Horii et al., 1999	WRD-OIC, Rumsey and Walker, 2016; MD, Pryor et al., 2002; FP, Sievering et al., 2001; FP, Meyers et al., 1998; FP, Meyers et al., 1989; FP, Huebert et al., 1988; FP, Huebert et al., 1985; Lee et al., 1993	MD, Hansen et al., 2015; MD, Myles et al., 2007; MD, Pryor et al., 2002

	HONO	N/A	N/A	AP, Zhang et al., 2012b; AP, Ren et al., 2011; AP, Zhou et al., 2011;
	NO _y	CL, Geddes et al., 2014; CL, Sparks et al., 2008; CL, Munger et al., 1996;	N/A	N/A
	N ₂ O ₅	N/A	Huff et al., 2011	N/A
<i>Particulate</i>	NO ₃ ⁻	AMS, Farmer et al., 2013; AMS, Farmer et al., 2011; AMS, Gordon et al., 2011;	WRD-OIC, Rumsey and Walker, 2016	FP, Rattray and Sievering, 2001; FP, Huebert et al., 1988
Reduced inorganic Nr				
<i>Gas</i>	NH ₃	CIMS, Shaw et al., 1998.	WRD-OIC, Rumsey and Walker, 2016; CL-Phillips et al., 2004; WEDD-OF, Pryor et al., 2001; FP, Rattray and Sievering, 2001; MD, Langford et al., 1992.	WEDD-OF, Hansen et al., 2015; MD, Myles et al., 2007
<i>Particulate</i>	NH ₄ ⁺	AMS, Farmer et al., 2013; AMS, Farmer et al., 2011	WRD-OIC, AGM, Rumsey and Walker, 2016; FP, Rattray and Sievering, 2001	N/A
Organic Nr				
<i>Gas</i>	Peroxy-nitrates	TD-CIMS, Wolfe et al., 2015; TD-LIF, TD-CIMS; Min et al, 2012; TD-CIMS, Wolfe et al., 2009; TD-LIF, Farmer et al., 2006; TD-CIMS, Turnipseed et al., 2006	MB-GC, Doskey et al., 2004	N/A
	ISOPN	Wolfe et al., 2015; CIMS, Nguyen et al., 2015	N/A	N/A
	MACN+MVKN	CIMS, Nguyen et al., 2015	N/A	N/A
	PROPNN	CIMS, Nguyen et al., 2015	N/A	N/A
	INP	CIMS, Nguyen et al., 2015	N/A	N/A
	MTNP	CIMS, Nguyen et al., 2015	N/A	N/A
	HCN	CIMS, Nguyen et al., 2015	N/A	N/A
<i>Particulate</i>	Total Alkyl-nitrates (gas + particle)	TD-LIF, Min et al, 2012; TD-LIF, Farmer et al., 2006; CIMS,	N/A	N/A

AMS: aerosol mass spectrometer

AP: absorption photometer

CIMS: chemical ionization mass spectrometer

CL: chemiluminescence

FP: filter pack

MD: manual denuder

MB-GC: manual bag-gas chromatography

TD-CIMS: thermal desorption-chemical ionization mass spectrometer

TD-LAS: tunable diode-laser absorption spectrometer

TD-LIF: thermal dissociation-laser induced fluorescence
WEDD-OF: wet effluent diffusion denuder-online fluorescence
WRD-OIC: wet rotating denuder-online ion chromatography
ISOPN: isoprene hydroxy nitrate
MACN_MVKN: hydroxy nitrates with carbon backbones of methacrolein and methylvinylketone
PROPNN: propanone or propanal nitrate
INP: isoprene nitrooxy hydroperoxide
MTNP: monoterpene nitrooxy hydroperoxide

Oxidized inorganic Nr

In addition to understanding the total deposition budget of Nr and categorizing the deposition processes to both wet and dry fractions, it is necessary to understand the composition of Nr deposition in order to identify portions that are subject to regulatory control. In the U.S., this is limited to the anthropogenic fraction of oxidized inorganic Nr which primarily originates from fossil fuel combustion. The oxidized Nr chemical system is summarized in Figure 2, illustrating the diversity of inorganic and organic species in both the particle and gas phase that make up the NOy budget.

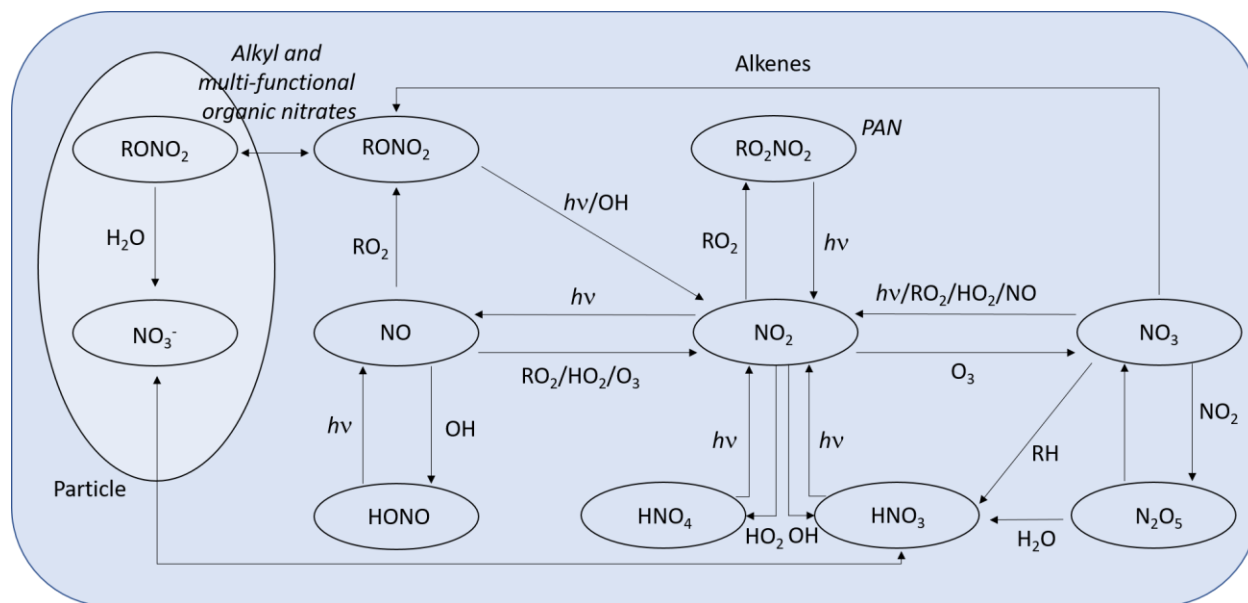

Figure 2. Schematic of the NO_y system. Adapted from Seinfeld and Pandis, 1998.

The flux of total oxidized Nr can be quantified by measuring the total NO_y flux, which is dominated by inorganics but may contain a significant organic fraction, both in gaseous and particulate forms (e.g., organic nitrates). Fluxes are typically measured by EC using a 3-D sonic anemometer for the micrometeorological parameters and the thermal conversion of all oxidized Nr to NO on a heated catalyst followed by detection of NO by chemiluminescence for ambient concentrations. While this approach is relatively straightforward compared to other

techniques for specific compounds, existing datasets are limited to a few forest sites (Geddes et al., 2014; Sparks et al., 2008; Munger et al., 1996). We note that the work of Munger and colleagues at Harvard Forest represents the only multi-year long-term dataset of Nr deposition in North America. Because NO_y is a bulk measurement of multiple species, it is most useful for budget development rather than process analysis and is most beneficial when conducted over temporal scales that allow for calculation of seasonal or annual budgets.

As illustrated in Figure 1, HNO₃ deposition dominates the oxidized Nr dry deposition budget, owing to its higher concentration relative to other compounds and large deposition velocity, which is generally thought to be limited only by atmospheric rather than surface resistances to deposition. For this reason, it is the most studied component of the NO_y deposition budget across a range of North American ecosystems. As detailed in Table 2, fluxes of HNO₃ have been quantified using gradient and REA methods employing a variety of analytical and batch sampling techniques. More recently, advancements in online chemical ionization mass spectrometry (Nguyen et al., 2015) and spectroscopic methods (Farmer et al., 2006; Horii et al., 1999) have allowed the use of EC techniques. While a number of datasets exist for model evaluation across a range of ecosystems, additional studies are needed to better understand the potential influences of surface chemistry on HNO₃ canopy resistance, which is assumed to be zero, and to quantify sources of uncertainty in measured canopy scale fluxes resulting from gas-particle interconversion within the NH₄NO₃ + HNO₃ + NH₃ system (i.e. flux divergence). The presence of an acid in equilibrium with NO₃⁻ salts on leaf surfaces (cuticle) may result in the presence of a “non-zero” surface resistance (R_c) for HNO₃ (Nemitz et al., 2004a). This case is typically assumed to deposit according to V_{dmax} , which is calculated at $1/(R_a + R_b)$ where R_a is the aerodynamic resistance to turbulent transfer and R_b is the diffusive resistance at the leaf boundary layer. Chemistry of the wet leaf cuticle, and its implications for resistance modeling of HNO₃ deposition, have not been well characterized for North American conditions (see Section **3.1.1.2 Measurements of surface chemistry/wetness relevant to fluxes**). Secondly, as summarized by Nemitz et al. (2004b) and references therein, perturbation of the NH₄NO₃ thermodynamic equilibrium within and above the canopy affects the vertical gradients NH₄NO₃ + HNO₃ + NH₃. NH₄NO₃ evaporation at the surface, for example, results in anomalous measurements of HNO₃ and NH₃ emissions from the canopy and corresponding over-fast NO₃⁻ deposition in which the measured deposition velocity (V_d) exceeds the velocity limited by turbulent transfer (V_{dmax}). This process can furthermore result in apparent emission of smaller particles from the canopy.

At the continental scale, NO_x (NO + NO₂), which is primarily NO₂, may contribute on the order of 5% of the Nr dry deposition budget (Figure 1). The NO_x fraction of the oxidized inorganic Nr flux has been studied relatively extensively in the context of in-canopy and near surface chemical processing within the NO_y system. Because the chemical timescale of the cycling of NO_x between NO and NO₂ is similar to the turbulence time scale, their canopy-scale fluxes will reflect a combination emission from the soil, deposition to the canopy, and in-situ chemical

processing. NO and NO₂ fluxes are measured by EC using several approaches. NO fluxes are measured directly by fast chemiluminescence (e.g., Geddes et al., 2014) whereby NO₂ fluxes may be determined directly by spectroscopic techniques (Horii et al., 2004; Farmer et al., 2006), or by fast NO chemiluminescence after conversion of NO₂ by photolysis (Geddes et al., 2014). Canopy scale NO and NO₂ fluxes have been conducted in a few evergreen (Blodgett Forest, Sierra Nevada Mountains, CA, Farmer et al., 2006; Min et al., 2014) and deciduous forests (Harvard Forest, MA, Horii et al., 2004; Haliburton Forest, Ontario, Geddes et al., 2014; and PROPHET site, MI, Geddes et al., 2014). Fluxes at these sites exhibit patterns of upward and downward canopy-scale fluxes of NO and NO₂, reflecting the net result of chemical processing within the canopy air-space and turbulent exchange. Results can depend on the specific location, for instance Geddes et al. (2014) noted that the fluxes at different times of day tended to offset in deciduous forests (in Haliburton, Ontario and at the PROPHET site in MI), yielding a total NO_x flux near zero, while net upward fluxes of NO and NO₂ were observed at an evergreen forest (Blodgett Forest in CA; Min et al., 2014). Net downward fluxes of NO₂ consistent with the presence of a compensation point were observed at Harvard Forest (Horii et al., 2004). Additional flux measurements are needed in locations such as urban to rural gradients where NO₂ contributes a more significant fraction of NO_y than experienced in rural locations more distant from sources. It is these locations where NO₂ will contribute more significantly to the Nr deposition budgets and where the accuracy of modeled deposition rates is likely more critical. NO and NO₂ fluxes have also been measured by EC from aircraft (Wolfe et al., 2015). Sitewise differences in patterns of NO_x air-surface exchange, and in the relative importance of in-situ chemical processing to the net canopy-scale flux, reinforce the need for measurements and models that explicitly quantify in-canopy and near-canopy sources and sinks as well as net-canopy scale exchange.

As shown in Figure 1, CMAQ suggests HONO and N₂O₅ (OXN_OTHR) likely make a relatively small contribution (2%) to the Nr deposition budget at the continental scale. Of the gas phase oxidized inorganic Nr compounds, HONO has received less attention than NO_x in terms of canopy-scale fluxes in North American natural ecosystems. As noted in Table 1, only a few published studies were identified, which describe fluxes measured by REA at the PROPHET deciduous forest site in Michigan (Zhang et al., 2012b; Zhou et al., 2011) and the Blodgett Forest ponderosa pine forest in California (Ren et al., 2011), both rural low-NO_x environments. Net upward fluxes from the canopy to the atmosphere were observed at both forest sites, with lower fluxes at Blodgett Forest corresponding to lower concentrations. Viewed in light of the deposition budget shown in Figure 1, which reflects a model algorithm in which HONO fluxes are unidirectional toward the surface, these studies point to the need for a more detailed treatment of within- and near-canopy chemistry in order to accurately resolve the net atmosphere-biosphere exchange of HONO. Additional measurements are also needed in natural ecosystems experiencing higher atmospheric concentrations of HONO than observed at these two rural forested sites. Measurements of N₂O₅ fluxes are more limited. The measurements of Huff et al. (2011) over a snow covered agricultural field are the only

published measurements that could be found for a North American terrestrial ecosystem. Fluxes suggested that N_2O_5 deposition was likely limited by turbulent transfer (i.e., similar to HNO_3), which is expected given its high solubility and is in agreement with N_2O_5 fluxes measured above the air-sea interface near San Diego, CA (Min et al., 2014). Additional measurements of N_2O_5 fluxes are needed, particularly in coastal zones and ecosystems downwind of urban areas. (Thornton, et al., 2010).

Nitrate aerosol (NO_3^-) is another component of the oxidized inorganic Nr budget, though is likely a relatively minor component at the continental scale (Figure 1). While the regional patterns and trends of atmospheric concentrations are relatively well characterized by national monitoring networks (e.g., CASTNET, IMPROVE), there exist relatively few published studies in which NO_3^- fluxes and deposition velocities have been directly measured in North America (Table 2). Earlier measurements (Huebert et al., 1988; Rattray and Sievering, 2001) employed filter packs to measure fluxes in a gradient mode, while online techniques employing steam aerosol collection and ion chromatography have been used more recently (Rumsey and Walker, 2016). Gradient studies have been conducted in grassland (Huebert et al., 1988; Rumsey and Walker, 2016) and alpine (Rattray and Sievering, 2001) environments. Recent advancement of online aerosol mass spectrometry has enabled the use of EC techniques for NO_3^- flux measurements at two North American forest sites (Blodgett Forest, CA, ponderosa pine, Farmer et al., 2011 and 2013; Borden Forest, Ontario, mixed deciduous/coniferous, Gordon et al., 2011).

While inorganic NO_3^- may make a relatively minor contribution to the Nr deposition budget at the continental scale, coastal environments, where deposition of coarse mode NO_3^- may contribute more significantly to the Nr deposition budget than fine mode NO_3^- at inland sites, represent an important geographical data gap. From a process standpoint, additional observations of NO_3^- flux, coincident with HNO_3 and NH_3 fluxes, are needed to better understand potential sources of uncertainty in measured canopy-scale fluxes resulting from gas-particle interconversion within the $\text{NH}_4\text{NO}_3 + \text{HNO}_3 + \text{NH}_3$ system (i.e. flux divergence), which, for example, Gordon et al. (2011) note may explain the observed positive NO_3^- fluxes from the canopy to atmosphere in their study at Borden Forest.

Reduced inorganic Nr

Reduced inorganic Nr (NH_x = gaseous NH_3 and particulate NH_4^+) in the atmosphere primarily originates from agricultural sources of NH_3 , including animal manure and fertilized soil (Reis et al., 2015), which, in contrast to oxidized Nr emissions, are not regulated in the U.S. As illustrated in Figure 1, deposition of gaseous NH_3 may be the dominant contributor to the continental scale Nr deposition budget. Furthermore, the relative contribution of reduced forms of nitrogen to the atmospheric inorganic nitrogen budget is increasing over time as NO_x emissions continue to decline (Li et al., 2016). Li et al. (2016) show that reduced nitrogen now dominates the inorganic Nr deposition budget across the U.S. and with the contribution of NH_3

dry deposition alone varying regionally from 19% (Northwest) to 63% (Southwest). Thus, knowledge of the role of NH_3 and NH_4^+ in Nr deposition budgets is becoming more important for understanding ecological impacts and for developing approaches to maintain or reduce deposition rates below critical Nr loads in North American ecosystems (Pardo et al., 2011). NH_3 is unique to other Nr compounds in that it is exchanged bi-directionally between the atmosphere and biosphere depending on the compensation point and emission potential of the underlying surface. NH_3 may be emitted from or taken up at the leaf surface via stomatal and cuticular pathways and may emit from or deposit to soil and the overlying litter layer (see Massad et al., 2010 and references therein).

Bidirectional NH_3 air-surface exchange algorithms used in North American deposition assessments, both at the field scale (Li et al., 2016) and within gridded chemical transport models (Zhang et al., 2010; Pleim et al., 2013; Bash et al., 2013; Zhu et al., 2015; Whaley et al., 2018), are largely based on parameterizations developed from European datasets (see Massad et al., 2010 and references therein). Stomatal and soil exchange pathways are regulated by NH_3 emission potentials that vary by vegetation and soil type along with other aspects of ecosystem biogeochemistry. Cuticular exchange processes are affected by the acidity of the exchange surface, which is influenced by the vegetation itself as well as the chemical composition of material deposited to the surface. Because these properties are to some extent ecosystem specific and dependent on atmospheric chemistry, datasets are needed to assess seasonal and annual net fluxes of NH_3 and to validate or revise current parameterization for North American conditions. The reader is referred to Section **3.2.1. Application of a bidirectional ammonia air-surface exchange model at NADP AMoN sites** for a detailed discussion of NH_3 air-surface exchange processes and associated knowledge and data gaps relevant to North America.

Table 1 summarizes published datasets of directly measured NH_3 and NH_4^+ fluxes in North American natural ecosystems. The work of Langford et al. (1992) summarizes early studies of NH_3 fluxes at a grassland (Pawnee grasslands, northeast CO) and forest sites (Walker Branch, Oak Ridge, TN) measured using batch collection techniques in a flux gradient configuration. More recent measurements have employed a range of gradient approaches employing batch collection of NH_3 using acid coated filters (alpine tundra, Rattray and Sievering, 2001); NH_3 conversion to NO by heated catalyst/chemiluminescence in gradient mode (grass, NC, Phillips et al., 2004) and continuously wetted denuder with online concentration measurement (Morgan-Monroe State Forest, deciduous, IN; Pryor et al., 2001; grass, NC, Rumsey and Walker, 2016). REA has been used with batch NH_3 collection by denuder (grass, FL, Myles et al., 2007) and by wet effluent diffusion denuder with online concentration measurement above a forest (Morgan-Monroe State Forest, deciduous, IN; Hansen et al., 2015). Shaw et al. (1998) report fluxes measured by EC over a grass field using a tandem mass spectrometer. Given the potential importance of NH_3 to the overall deposition budget, additional measurements in geographically diverse natural ecosystems and under differing NH_3 concentrations are urgently needed.

While a number of studies have been conducted in grasslands and to a lesser extent forests, coastal ecosystems, wetlands, arid zones represent geographical gaps where NH_3 flux measurements are needed. Additionally, flux measurements are needed within and downwind of agricultural areas to better characterize rates of NH_3 deposition to natural ecosystems experiencing elevated NH_3 concentrations see Section **3.4.2. Spatial variability of ammonia in agricultural regions**. It is also notable that the only published datasets for forests (Langford et al., 1992; Pryor et al., 2001; and Hansen et al, 2015) are for mixed-hardwood ecosystems; published studies in coniferous North American forests could not be identified. From a process standpoint, additional flux datasets are needed in deciduous and coniferous forest ecosystems targeting a range of atmospheric concentrations of NH_3 and atmospheric acidity. Supporting datasets of surface wetness and biogeochemistry are also critical for interpreting fluxes within the context of surface emission potentials and cuticle chemistry. The reader is referred to Sections **3.1.1.2. Measurements of surface chemistry/wetness relevant to fluxes'** and Section **3.2.1. Application of a bidirectional ammonia air-surface exchange model at NADP AMoN sites** for a more detailed discussion of knowledge and data gaps related to better understanding the role of surface wetness in NH_3 air-surface exchange and role of biogeochemistry in the measurement and modeling of NH_3 fluxes.

From a technological standpoint, open-path techniques suitable for EC NH_3 fluxes are advancing (Sun et al., 2015) and show promise for application to flux measurements in natural ecosystems. Open-path technology has an obvious advantage in avoiding inlet NH_3 effects which limit the effective response time of fast detectors such as quantum cascade laser (QCL), tunable diode laser (TDL), or chemical ionization mass spectrometry (CIMS) systems in a "closed" configuration (Zoll et al., 2016; Famulari et al., 2004; Ellis et al., 2010; Sintermann et al., 2011; Ferrara et al., 2012).

Owing to relatively low deposition velocities for particles, NH_4^+ makes a much smaller contribution to the overall Nr deposition budget than NH_3 (Figure 1). As with NO_3^- , the regional patterns and trends of atmospheric concentrations of NH_4^+ aerosol are relatively well characterized by national monitoring networks (e.g., CASTNET, IMPROVE). However, published direct flux measurements for North American sites appear to be limited to three studies (Table 1). Rattray and Sievering (2001) employed batch collection with filter packs in a gradient configuration to measure fluxes above alpine tundra (Niwot Ridge, CO). Rumsey and Walker (2016) used a steam-jet aerosol collector with online ion-chromatography in gradient mode to measure fluxes over grass (Chapel Hill, NC). Aerosol mass spectrometry was used to measure fluxes by EC at a single North American forest site (Blodgett Forest, CA, ponderosa pine, Farmer et al., 2011 and 2013). As with NO_3^- , additional studies of NH_4^+ deposition are needed to better understand potential sources of uncertainty in measured canopy scale fluxes resulting from gas-particle interconversion within the $\text{NH}_4\text{NO}_3 + \text{HNO}_3 + \text{NH}_3$ system (i.e. flux divergence).

Organic Nr

On a global basis, organic Nr may contribute ~ 25% of the total Nr deposition in precipitation (Jickells et al., 2013), yet the composition, sources, and deposition processes for organic Nr remain poorly characterized for all but a relatively few compounds or groups of compounds. Organic Nr comprises a wide range of gaseous and particulate forms whose sources include soil dust, biomass burning, agricultural, marine, and anthropogenic emissions. Classes of compounds include primary emissions and secondary reaction products such as amines and amino acids, urea, nitrophenols, alkyl amides, N-heterocyclic alkaloids, and organic nitrates (Jickells et al., 2013; Cape et al., 2011). Dry deposition of organic Nr remains poorly characterized at the global scale, though technological advances in measurement techniques suitable for flux measurements have led to an increase in dry deposition studies in recent years. The reader is referred to section 3.1.2.5. ***Characterization of organic nitrogen in air and precipitation*** for a detailed discussion of the current state of the science of organic Nr measurements. Here we provide a brief summary of published measurements of dry deposition and bi-directional air-surface exchange of organic Nr compounds for North American natural ecosystems.

Oxidized organic Nr

With respect to air-surface exchange, the oxidized portion of organic Nr in the atmosphere has been studied in the context of particulate and gas phase organic nitrates. When VOCs are present, NO_x can react with organic peroxy radicals (RO₂) to form peroxy nitrates (RO₂NO₂) and alkyl and multifunctional nitrates (RONO₂) (Figure 2). Peroxy nitrates (PNs) may account for 10–80% of total NO_y in high NO_x environments (Roberts, 1990; Roberts et al., 2004; Cleary et al., 2007; Murphy et al., 2006; Day et al., 2008), with PAN contributing the majority of the PN budget. PN species exist in the gas phase and are thermally unstable, with lifetimes ranging from a few hours to weeks depending on temperature. In the context of air-surface exchange, PNs are the most studied class of organic Nr compounds in North America. Figure 1 shows that PNs may contribute on the order of 5% of the total Nr dry deposition budget at the continental scale.

As summarized in Table 1, PNs are reported as speciated PAN, peroxypropionyl nitrate (PPN) and peroxyacetyl nitrate (MPAN), where total acyl peroxy nitrates (APN) = PAN + PPN + MPAN, or as total peroxy nitrates (ΣPN). With the exception of a single study employing the gradient method and offline analysis of bag samples (Doskey et al., 2004), fluxes are typically measured by EC using online CIMS (Turnipseed, 2006) or thermal dissociation to NO₂ followed by laser induced fluorescence (TDLIF, Farmer et al., 2008). In North America, fluxes have been measured over grass (Doskey et al., 2004); loblolly pine (Duke Forest, Chapel Hill, NC, Turnipseed et al., 2006); ponderosa pine (Blodgett Forest, CA, Farmer et al., 2006; Wolfe et al., 2009; Min et al., 2012); and by aircraft over the southeastern U.S. (Wolfe et al., 2015).

PN fluxes have been studied extensively at the Blodgett Forest (ponderosa pine, CA) and observations spanning multiple years reflect the complexities of PN air-surface exchange. Farmer et al. (2008) report a net upward flux of ΣPN from the canopy in a 2004 study, driven by production within the canopy air-space. Wolfe et al. (2009) report net deposition of PAN, PPN,

and MPAN during BEARPEX-2007, with the majority of deposition attributed to stomatal uptake and vertical gradients in PAN decomposition, leaving a small residual flux attributed to “non-stomatal” uptake. Min et al. (2012) also report net deposition of APN during BEARPEX-2009, but much smaller net fluxes of Σ PN attributed to in-canopy production and emission of PN species other than APNs. Differences across years may be attributed to differences in photochemical conditions and biogenic emissions of PN precursors. Wolfe estimate an overall contribution of PN to the Nr deposition budget at their site of 4–19%. Across PN species, Wolfe et al reporting larger deposition velocities for PPN than PAN and MPAN while Turnipseed et al (2006) reporting similar deposition velocities for the three compounds. Turnipseed reported that approximately half of daytime deposition could be explained by stomatal uptake and that night-time fluxes tended to be larger when the canopy was wet.

Similar to the studies of NO_x and HONO, which show a combination of net emission and deposition to the canopy across sites and time periods, measurements of PAN fluxes reiterate the importance of quantifying the role of in-canopy chemistry in net canopy exchange with the atmosphere, processes which are not captured in the model algorithms employed in most chemical transport models, including CMAQ. Deciduous forests represent a notable data gap for PN fluxes were additional measurements are needed.

Alkyl and multifunctional nitrates (ANs), which can exist in the gas or particle phase, can be the dominant chemical sink for NO_x in high biogenic volatile organic compound (BVOC)/low NO_x environments (Browne and Cohen, 2012; Paulot et al., 2012; Browne et al., 2014). Recent aircraft and ground-based observations combined with GEOS-CHEM simulations show that gas-phase isoprene nitrates account for 25-50% of surface RONO₂, 10% contribution for gas phase monoterpene nitrates, and approximately 10% in the particle phase (Fisher et al., 2016). CMAQ simulations suggest that the gas phase portion of these “other” organic nitrates may contribute on the order of 4% of the total Nr deposition budget (Figure 1, “OXN_ORGN”). While understanding of the importance of ANs to the NO_x budget and the AN chemical system is expanding rapidly, the processes of AN air surface exchange is poorly known. Only four North American studies (Table 1) could be identified in which air-surface exchange of ANs was directly measured. In all cases, fluxes were measured by EC using TD-LIF (Farmer et al., 2006; Min et al., 2012) or CIMS (Wolfe et al., 2015; Nguyen et al., 2015). Measurements of total AN fluxes (gas + particulate) at the Blodgett Forest ponderosa pine site during 2004 and 2005 showed net downward fluxes to the canopy, with a median V_d of 2.1 cm s⁻¹, indicating the presence of a surface resistance when compared with the maximum V_d allowed by turbulence (Farmer et al., 2006). Min et al. (2012) report that total alkyl nitrate fluxes were also measured during BEARPEX 2009 at Blodgett Forest but the fluxes themselves are not reported.

Published measurements of speciated alkyl nitrate fluxes at North American sites are also few. EC fluxes of isoprene hydroxy nitrates (ISOPN) have been measured by CIMS (Wolfe et al., 2015; Nguyen et al.; 2015). Wolfe et al. (2015) report an average deposition velocity of 1.1 cm s⁻¹ from aircraft flux measurements over the “isoprene volcano” region of the Ozark mountains, which agrees with the ground-based flux measurements (mean V_d of 1.5 cm s⁻¹) of Nguyen et al. (2015, SOAS study) over a mixed coniferous/deciduous forest in the southeastern U.S. Nguyen

et al. (2015) also report CIMS EC fluxes of several other multifunctional gas phase organic nitrates, including methacrolein and methyl vinyl ketone hydroxy nitrates (MACN + MVKN), propanone nitrate (PROPNN), isoprene nitrooxy hydroperoxide (IPN), and monoterpene nitrooxy hydroperoxide (MTNP). With the exception of MTNP, average deposition velocities of these compounds are similar over the approximately 4-week period of study, ranging from 1.3 to 1.7 cm s⁻¹. The V_d for MTNP was lower, averaging 0.8 cm s⁻¹. All species deposited more slowly than allowable by purely turbulent exchange, indicating the presence of a surface resistance.

Reduced forms of organic Nr

While measurements of rainfall composition suggest that reduced Nr compounds may cumulatively make a significant contribution to the atmospheric organic Nr budget (Neff et al., 2002; Altieri et al., 2012), the processes by which reduced organic Nr compounds dry deposit are largely unknown, explaining the lack of representation in chemical transport models such as CMAQ (i.e., not included in the Figure 1 budget). Fluxes of hydrogen cyanide (HCN) measured by Nguyen et al. (2015) are the only published dry deposition data for reduced organic Nr compounds that could be identified in the literature. HCN is of interest as a tracer for biomass burning (Rinsland et al., 1999). Nguyen et al. (2015) report a very low average V_d = 0.3 cm s⁻¹ over a mixed coniferous/deciduous forest during summer (SOAS study), likely resulting from low solubility and reactivity at the leaf surface. Measurements of air-surface exchange of other gas phase reduced organic Nr compounds, such as amino acids, aliphatic amines, N-containing nitroso compounds could not be identified.

Future research

The data and knowledge gaps summarized above motivate research needed to address the incompleteness of dry deposition budgets, more fully characterize temporal and geographical variability of fluxes, and better understand air-surface exchange processes to improve models used for deposition assessments. These research needs can further be broken down into near- and longer-term efforts.

Completeness of deposition budgets - Model deposition budgets used for critical loads assessments do not include the full contribution of organic Nr forms. Global measurements (Jickells et al., 2013) suggest that omission of the water soluble organic Nr fraction may result in a low bias of the wet Nr deposition budget by 25% on average; total contribution of organic Nr to the dry deposition fraction is unknown. Development of a routine method for measurement of bulk organic Nr in precipitation could be accomplished in the relatively near term, while implementation of such measurements into routine monitoring of wet deposition across North America is a longer-term effort.

For reduced organic Nr species, techniques which allow for direct measurement of the total reduced Nr flux (Brummer et al., 2013) represent an important first step in accounting for this component of the dry deposition budget and could be implemented in the near term. For

oxidized organic Nr, application of bulk alkyl and peroxy nitrate converter methods (Farmer et al., 2006) to chemiluminescence detection for EC fluxes could be explored in the near term. Separation of aerosol and gas phase contributions to the total oxidized organic Nr flux using coincident online aerosol and gas phase mass spectrometry methods is a long-term goal. Following advances in measurements of oxidized organic Nr forms (Nguyen et al., 2015), application of online mass spectrometry techniques to quantify speciated fluxes of amines and amides (You et al., 2014; Yao et al., 2016) may also be possible in the short term.

Temporal and geographical variability of fluxes - With exception of the work of Munger et al. (1996) at Harvard Forest, most air-surface exchange data sets span periods of a few weeks to months, failing to capture the range of atmospheric, biogeochemical, and phenological conditions that drive annual scale fluxes. For this reason, establishment of long-term sites for process level measurements of reactive chemical fluxes is viewed as a high priority long-term endeavor of the atmospheric chemistry and ecological communities. Because the expense of process-level measurements makes the establishment of a large number of sites unfeasible, in the shorter term low-cost approaches for direct flux measurements, such as the Conditional Time-Averaged Gradient (COTAG) technique (Famulari et al., 2010 and Section **3.1.2.4. Low-cost method for routine monitoring of air-surface exchange of Nr compounds**) could be deployed in a routine monitoring mode, within existing infrastructure (e.g., CASTNET, NADP, Ameriflux) to quantify dry deposition for seasonal and annual deposition budgets.

Short term flux measurements also miss potentially important deposition episodes. For example, large enhancements of Nr compounds have been observed in smoke plumes (Benedict et al., 2017; Prenni et al., 2014). While these observations demonstrate that smoke plumes represent a significant source of site-specific temporal variability in atmospheric Nr, there remains a paucity of measurements sufficient to characterize the importance of biomass burning episodes to annual deposition budgets, which may be particularly important at remote sites where background Nr deposition is low. Characterization of Nr deposition associated with smoke plumes is a high priority but likely a longer-term, opportunistic effort.

With respect to Nr flux measurements in natural ecosystems, low elevation forests and grasslands have been studied most extensively. However, with the exception of HNO₃, relatively few geographical locations have been characterized. As a general conclusion, more measurements are needed in forest ecosystems, particularly deciduous forests. Other specific geographical gaps include:

- *High elevation and alpine environments* are particularly sensitive to Nr inputs and may thus exhibit relatively low critical Nr loads. There are only a very few studies of direct flux measurements in high elevation ecosystems, owing to the challenges of applying flux measurement techniques in non-ideal terrain and the generally low concentrations observed in these remote areas.

- *Urban-to-rural gradients* represent areas where deposition of oxidized Nr forms to natural ecosystems is expected to be large and poorly understood species such as NO₂ and HONO may make particularly important contributions.
- *Agricultural regions* represent areas where NH₃ deposition is highly spatially variable. NH₃ fluxes to natural ecosystems at high concentrations typical of agricultural areas are not well characterized. These may also be areas where reduced organic Nr forms (e.g., aliphatic amines) may be particularly important.
- *Coastal zones* represent areas where coarse NO₃⁻ aerosol and organic Nr compounds from marine sources may be particularly important components of the dry deposition budget.
- Dry deposition is the dominant pathway in *arid ecosystems*, which cover large areas of the western U.S. Measurements of fluxes in these ecosystems are limited (Fenn et al., 2009). Additional measurements that elucidate the processes of exchange with the soil surface are particularly needed (Padgett et al., 1999, 2001).

Experiments targeting these specific environments are a long-term objective.

Air-surface exchange processes - Efforts are underway to develop a global metadatabase of Nr fluxes to facilitate collaboration in the area of dry deposition model development. The purpose of this effort is to establish a publicly available, searchable archive that can be queried to easily assess where and when measurements of Nr fluxes have been conducted. While this information is easily accessible for more routine measurements (e.g., wet deposition, air concentrations) collected within networks, direct measurements of air-surface exchange of particles and trace gases (i.e., dry deposition and bidirectional exchange) are typically conducted in intensive, shorter-term studies. These datasets are therefore often less visible and accessible to the user community. Establishment of a publicly available metadatabase for Nr flux measurements would serve the atmospheric science and ecological communities interested in better understanding the processes and drivers of land-atmosphere exchange of Nr and development of models to better simulate these processes.

The review of existing North American flux datasets points to several data and knowledge gaps related to air-surface exchange *processes* that need to be addressed in order to advance model algorithms. Several studies summarized above challenge the fundamental conceptual framework of air-surface exchange employed in field-scale and gridded chemical transport models, which is that PM and oxidized forms of gas phase Nr always deposit from the atmosphere to the surface. Measurements in several forest ecosystems document the importance of in-canopy chemical processes in regulating the net flux between the atmosphere and biosphere, which can result in net loss from the canopy. These results point to the need for studies to quantify within- and near-canopy sources and sinks of the components of the chemical system under study (e.g., NO_y or HNO₃-NH₃-NH₄NO₃) such that models can be advanced to incorporate underlying biological, chemical, and physical processes as described in Section **3.2.2. Development of in-canopy source/sink models that resolve deposition to**

ecosystem components (crown, understory, ground) and in-canopy chemistry. This is a high priority and represents a long-term effort.

Measurements to elucidate the role of surface wetness and cuticle chemistry in the canopy resistances for gas phase HNO₃, NH₃, and PNs are also seen as a high priority. Assessment of the volume and chemistry of dew (e.g., Wentworth et al., 2016) and guttation could be incorporated into flux experiments in the near term, which could help improve parameterizations of “non-stomatal” deposition pathways and surface resistances. For NH₃, flux measurements should also be accompanied by measurements of soil and vegetation chemistry in order to constrain the emission potentials responsible for soil and stomatal compensation points. Such measurements could also be incorporated into flux experiments in the short term.

From a technological standpoint, further development of open-path techniques for NH₃ flux measurements is a short-term, high priority objective.

Extension of micrometeorological flux measurement techniques to complex terrain typical of N_r sensitive high-elevation environments is also a long-term objective.

Opportunities for collaboration - This review also highlights the need for closer collaboration between the atmospheric chemistry and ecological communities with respect to advancement of N_r deposition budgets in North America. Coordinated multi-agency field studies, leveraging expertise and resources, can be a cost-effective approach to addressing the most urgent process-oriented research questions. Historically, large-scale atmospheric measurement campaigns in the U.S. have been developed and coordinated by the atmospheric chemistry community. While measurements of N_r and deposition are often components of these studies, the NADP TDep community could engage with these efforts more directly to advocate for science objectives that integrate atmospheric chemistry and ecological questions relevant to N_r deposition.

References

- Altieri, K.E., Hastings, M.G., Peters, A.J., Sigman, D.M. (2012) Molecular characterization of water soluble organic nitrogen in marine rainwater by ultra-high resolution electrospray ionization mass spectrometry. *Atmos. Chem. Phys.*, 12, 3557-3571.
- Baldocchi, D.D., Hicks, B.B., Meyers, T.P. (1988). Measuring biosphere-atmosphere exchanges of biologically related gases with micrometeorological methods. *Ecology*, 69, 1331-1340.
- Bash, J.O., Cooter, E.J., Dennis, R.L, Walker, J.T., Pliem, J.E. (2013). Evaluation of a regional air-quality model with bidirectional NH₃ exchange coupled to an agroecosystem model. *Biogeosciences*, 10, 1635-1645.

- Benedict, K.B., Prenni, A.J., Carrico, C.M., Sullivan, A.P., Schichtel, B.A., Collett Jr., J.L. (2017). Enhanced concentrations of reactive nitrogen species in wildfire smoke. *Atmos. Environ.*, 148, 8–15.
- Bowker, G.E., Schwede, D.B., Lear, G.G., Warren-Hicks, W.J., Finkelstein, P.L. (2011). Quality Assurance Decisions with Air Models: A Case Study of Imputation of Missing Input Data Using EPA's Multi-Layer Model. *Water, Air, Soil Poll.*, 223, 391-402.
- Browne, E.C., Cohen, R.C. (2012). Effects of biogenic nitrate chemistry on the NO_x lifetime in remote continental regions. *Atmos. Chem. Phys.*, 12, 11917–11932.
- Browne, E.C., Wooldridge, P.J., Min, K.-E., Cohen, R.C. (2014). On the role of monoterpene chemistry in the remote continental boundary layer. *Atmos. Chem. Phys.*, 14, 1225–1238.
- Brümmer, C., Marx, O., Kutsch, W., Ammann, C., Wolff, V., Flechard, C.R., Freibauer, A. (2013). Fluxes of total reactive atmospheric nitrogen (Nr) using eddy covariance above arable land. *Tellus Ser B*, 65, 19770.
- Businger, J.A. and Oncley, S.P. (1990). Flux Measurement with Conditional Sampling. *J. Atmospheric and Oceanic Technology*, 7, 349-352.
- Cape, J.N., Cornell, S.E., Jickells, T.D., and Nemitz, E. (2011). Organic nitrogen in the atmosphere – Where does it come from? A review of sources and methods. *Atmos. Res.*, 102, 30–48.
- Cleary, P.A., Wooldridge, P.J., Millet, D.B., McKay, M., Goldstein, A.H., Cohen, R.C. (2007). Observations of total peroxy nitrates and aldehydes: measurement interpretation and inference of OH radical concentrations, *Atmos. Chem. Phys.*, 7, 1947– 1960.
- Day, D.A., Wooldridge, P.J., Cohen, R. C. (2008). Observations of the effects of temperature on atmospheric HNO₃, sumANs, sumPNs, and NO_x: evidence for a temperature-dependent HO_x source. *Atmos. Chem. Phys.*, 8, 1867–1879.
- Delany, A.C., Fitzjarrald, D.R., Lenschow, D.H., Pearson, R. Jr., Wendel, G.J., Woodruff, B. (1986). Direct measurements of nitrogen oxides and ozone fluxes over grassland. *J. Atmos. Chem.*, 4, 429-444.
- Dennis, R.L., Schwede, D.B., Bash, J.O., Pleim, J.E., Walker, J.T., Foley, K.M. (2013) Sensitivity of continental United States atmospheric budgets of oxidized and reduced nitrogen to dry deposition parameterizations. *Philos. Tr. R. Soc. B*, 368, 20130124.
- Doskey, P. V., Kotamarthi, R. V., Fukui, Y., Cook, D. R., Breitbeil III, F. W., Wesely, M. L. (2004). Air-surface exchange of peroxyacetyl nitrate at a grassland site. *J. Geophys. Res. Atm.*, 109, D10310.

- Ellis, R.A., Murphy, J.G., Pattey, E., van Haarlem, R., O'Brien, J.M., Herndon, S.C. (2010). Characterizing a Quantum Cascade Tunable Infrared Laser Differential Absorption Spectrometer (QCTILDAS) for measurements of atmospheric ammonia. *Atmos. Meas. Tech.*, 3, 397–406.
- Famulari, D., Fowler, D., Hargreaves, K., Milford, C., Nemitz, E., Sutton, M. A., Weston, K. (2004). Measuring eddy covariance fluxes of ammonia using tunable diode laser absorption spectroscopy. *Water Air Soil Pollut.*, 4, 151–158.
- Famulari, D., Fowler, D., Nemitz, E., Hargreaves, K.J., Storeton-West, R.L., Rutherford, G., Tang, Y.S., Sutton, M.A., Weston, K.J. (2010). Development of a low-cost system for measuring conditional time-averaged gradients of SO₂ and NH₃. *Environmental Monit. Assess.*, 161, 11-27.
- Farmer, D.K., Wooldridge, P.J., Cohen, R.C. (2006). Application of thermal-dissociation laser induced fluorescence (TD-LIF) to measurement of HNO₃, Σ alkyl nitrates, Σ peroxy nitrates, and NO₂ fluxes using eddy covariance. *Atmos. Chem. Phys.*, 6, 3471–3486.
- Farmer, D. K., Cohen, R. C. (2008). Observations of HNO₃, PP AN, PN and NO₂ fluxes: evidence for rapid HO_x chemistry within a pine forest canopy, *Atmos. Chem. Phys.*, 8, 3899–3917.
- Farmer, D.K., Kimmel, J.R., Phillips, G., Docherty, K.S., Worsnop, D.R., Sueper, D., Nemitz, E., Jimenez, J.L. (2011). Eddy covariance measurements with high-resolution time-of-flight aerosol mass spectrometry: A new approach to chemically resolved aerosol fluxes. *Atmos. Meas. Tech.*, 4, 1275–1289.
- Farmer, D.K., Chen, Q., Kimmel, J.R., Docherty, K.S., Nemitz, E., Artaxo, P.A., Cappa, C.D., Martin, S.T., Jimenez, J.L. (2013). Chemically-resolved particle fluxes over tropical and temperate forests. *Aerosol Sci. Tech.*, 47, 818-830.
- Fenn, M.E., Sickman, J.O., Bytnerowicz, A., Clow, D.W., Molotch, N.P., Pleim, J.E., Tonnesen, G.S., Weathers, K.C., Padgett, P.E., Campbell, D.H. (2009). Methods for measuring atmospheric nitrogen deposition inputs in arid and montane ecosystems of western North America. In: Legge, A.H., ed. 2009. *Developments in Environmental Science, Vol. 9: Air Quality and Ecological Impacts: Relating Sources to Effects*. Elsevier, Amsterdam. pp.179-228
- Ferrara, R. M., Loubet, B., Di Tommasi, P., Bertolini, T., Magliulo, V., Cellier, P., Eugster, W., Rana, G. (2012). Eddy covariance measurement of ammonia fluxes: Comparison of high frequency correction methodologies, *Agr. Forest Meteorol.*, 158, 30– 42.
- Fisher, J.A., Jacob, D.J., Travis, K.R., Kim, P.S., Marais, E.A., Miller, C.C., Yu, K., Zhu, L., Yantosca, R.M., Sulprizio, M.P., Mao, J., Wennberg, P.O., Crouse, J.D., Teng, A.P., Nguyen, T.B., St Clair, J.M., Cohen, R.C., Romer, P., Nault, B.A., Wooldridge, P.J., Jimenez, J.L., Campuzano-Jost, P., Day, D.A., Hu, W., Shepson, P.B., Xiong, F., Blake, D.R., Goldstein, A.H., Misztal, P.K., Hanisco, T.F., Wolfe, G.M., Ryerson, T.B., Wisthaler, A., Mikoviny, T. (2016). Organic nitrate chemistry and its implications for nitrogen budgets in an isoprene- and monoterpene-rich atmosphere:

constraints from aircraft (SEAC4RS) and ground-based (SOAS) observations in the Southeast US. *Atmos. Chem. Phys.*, 16, 5969-5991.

Flechard, C.R., Nemitz, E., Smith, R.I., Fowler, D., Vermeulen, A.T., Bleeker, A., Erisman, J.W., Simpson, D., Zhang, L., Tang, Y.S., Sutton, M.A. (2011). Dry deposition of reactive nitrogen to European ecosystems: a comparison of inferential models across the NitroEurope network, *Atmos. Chem. Phys.*, 11, 2703–2728.

Geddes, J.A., Murphy, J.G. (2014). Observations of reactive nitrogen oxide fluxes by eddy covariance above two mid-latitude North American mixed hardwood forests. *Atmos. Chem. Phys.*, 14, 2939-2957.

Gordon, M., Staebler, R.M., Liggio, J., Vlasenko, A., Li, S.-M., Hayden, K. (2011). Aerosol flux measurements above a mixed forest at Borden, Ontario. *Atmos. Chem. Phys.*, 11, 6773-6786.

Hansen, K., Pryor S.C., Boegh, E., Hornsby, K.E., Sørensen, L.L. (2015). Background concentrations and fluxes of atmospheric ammonia over a deciduous forest. *Agric. For. Meteorol.*, 214-215, 380-392.

Horii, C.V., Zahniser, M., Nelson, D., McManus, J.B., Wofsy, S.C. (1999). Nitric acid and nitrogen dioxide flux measurements: a new application of Tunable Diode Laser Absorption Spectroscopy. *Proceedings of SPIE*, 3758, 152–161.

Horii, C.V., Munger, J.W., Wofsy, S.C., Zahniser, M., Nelson, D., McManus, J.B. (2004). Fluxes of nitrogen oxides over a temperate deciduous forest. *J. Geophys. Res. Atmos.*, 109, D08305. doi:10.1029/2003JD004326.

Huebert, B. J., Robert, C.H. (1985). The dry deposition of nitric acid to grass. *J. Geophys. Res. Atmos.*, 90, 2085-2090.

Huebert, B.J., Luke, W.T., Delany, A.C., Brost, R.A. (1988). Measurements of concentrations and dry surface fluxes of atmospheric nitrates in the presence of ammonia. *J. Geophys. Res. Atmos.*, 93, 7127-7136.

Huff, D.M., Joyce, P.L., Fochesatto, G.J., Simpson, W.R. (2011). Deposition of dinitrogen pentoxide, N₂O₅, to the snowpack at high latitudes. *Atmos. Chem. Phys.*, 11, 4929–4938

Jickells, T., Baker, A.R., Cape, J.N., Cornell, S.E., Nemitz, E. (2013). The cycling of organic nitrogen through the atmosphere. *Philos. Tr. R. Soc. B.*, 368, 20130115.

Katul, G., Finkelstein, P.L., Clarke, J.F., Ellestad, T.G. (1996). An investigation of the conditional sampling methods used to estimate fluxes of active, reactive and passive scalars. *J. Appl. Meteorol.*, 35, 1835–1845.

- Kim, M.J., Farmer, D.K., Bertram, T.H. (2014). A controlling role for the air-sea interface in the chemical processing of reactive nitrogen in the coastal marine boundary layer. *P. Natl. Acad. Sci. USA*, 111, 3943-3948.
- Langford, A., Fehsenfeld, F., Zachariassen, J., Schimel, D. (1992). Gaseous ammonia fluxes and background concentrations in terrestrial ecosystems of the United States. *Global Biogeochem. Cy.*, 6, 459-483.
- Lee, G., Zhuang, L., Huebert, B.J., Meyers, T.P. (1993). Concentration gradients and dry deposition of nitric acid vapor at the Mauna Loa Observatory, Hawaii. *J. Geophys. Res.*, 98, 12661-12671.
- Li, Y., Schichtel, B., Walker, J.T., Schwede, D.B., Chen, X.I., Lehmann, C., Puchalski, M., Gay, D., Collett, J.L. Jr. (2016). The Increasing Importance of Deposition of Reduced Nitrogen in the United States. *P. Natl. Acad. Sci. USA*, 113, 5874–5879.
- Massad, R.-S., Nemitz, E., Sutton, M.A. (2010). Review and parameterization of bi-directional ammonia exchange between vegetation and the atmosphere. *Atmos. Chem. Phys.*, 10, 10359-10386.
- Meyers, T.P., Huebert, B.J., Hicks, B.B. (1989). HNO₃ deposition to a deciduous forest. *Bound.-Lay. Meteorol.*, 49, 395–410.
- Meyers T.P., Finkelstein P., Clarke J., Ellestad T.G., & Sims P.F. (1998). A multilayer model for inferring dry deposition using standard meteorological measurements. *J. Geophys. Res. Atmos.*, 103, 22645-22661.
- Min, K.-E., Pusede, S. E., Browne, E. C., Lafranchi, B.W., Wooldridge, P.J., Wolfe, G.M., Harrold, S.A., Thornton, J. A., Cohen, R.C. (2012). Observations of atmosphere-biosphere exchange of total and speciated peroxy nitrates: Nitrogen fluxes and biogenic sources of peroxy nitrates, *Atmos. Chem. Phys.*, 12, 9763-9773.
- Min, K.-E., Pusede, S.E., Browne, E.C., LaFranchi, B.W., Cohen, R.C. (2014). Eddy covariance fluxes and vertical concentration gradient measurements of NO and NO₂ over a ponderosa pine ecosystem: observational evidence for within-canopy chemical removal of NO_x. *Atmos. Chem. Phys.*, 14, 5495-5512.
- Munger, J. W., Wofsy, S.C., Bakwin, P.S., Fan, S.M., Goulden, M.L., Daube, B.C., Goldstein, A.H., Moore, K.E., Fitzjarrald, D.R. (1996), Atmospheric deposition of reactive nitrogen oxides and ozone in a temperate deciduous forest and a subarctic woodland .1. Measurements and mechanisms. *J. Geophys. Res. Atmos.*, 101, 12639-12657.
- Murphy, J. G., Day, D. A., Cleary, P. A., Wooldridge, P. J., Cohen, R. C. (2006). Observations of the diurnal and seasonal trends in nitrogen oxides in the western Sierra Nevada. *Atmos. Chem. Phys.*, 6, 5321–5338.

Myles, L., Meyers, T.P., Robinson, L. (2007). Relaxed eddy accumulation measurements of ammonia, nitric acid, sulfur dioxide and particulate sulfate dry deposition near Tampa, FL, USA. *Environ. Res. Lett.*, 2, 034004.

Neff, J.C., Holland, E.A., Dentener, F.J., McDowell, W.H., Russell, K.M. (2002). The origin, composition and rates of organic nitrogen deposition: a missing piece of the nitrogen cycle? *Biogeochem.*, 57, 99–136.

Nemitz, E., Sutton, M. A., Wyers, G. P., Jongejan, P.A.C. (2004a). Gas-particle interactions above a Dutch heathland: I. Surface exchange fluxes of NH₃, SO₂, HNO₃ and HCl. *Atmos. Chem. Phys.*, 4, 989-1005.

Nemitz, E., Sutton, M. A., Wyers, G. P., Otjes, R. P., Mennen, M. G., van Putten, E. M., Gallagher, M. W. (2004b). Gas-particle interactions above a Dutch heathland: II. Concentrations and surface exchange fluxes of atmospheric particles. *Atmos. Chem. Phys.*, 4, 1007 – 1024.

Nguyen, T.B, Crouse, J.D., Teng, A.P., St. Clair, J.M., Paulot, F., Wolfe, G.M., Wennberg, P.O. (2015). Rapid deposition of oxidized biogenic compounds to a temperate forest. *Proc. Nat. Acad. Sci. USA*, 112, E392–E401.

Padgett, P.E., and Bytnerowicz, A. (2001). Deposition and adsorption of the air pollutant HNO₃ vapor to soil surfaces. *Atmos. Environ.* 35, 2405–2415.

Padgett, P.E., Allen, E.B., Bytnerowicz, A., and Minich, R.A. (1999). Changes in soil inorganic nitrogen as related to atmospheric nitrogenous pollutants in southern California. *Atmos. Environ.* 33, 769–781.

Pardo, L. H., Fenn, M., Goodale, C. L., Geiser, L. H., Driscoll, C. T., Allen, E., Baron, J., Bobbink, R., Bowman, W. D., Clark, C., Emmett, B., Gilliam, F. S., Greaver, T., Hall, S. J., Lilleskov, E. A., Liu, L., Lynch, J., Nadelhoffer, K., Perakis, S., Robin-Abbott, M. J., Stoddard, J., Weathers, K., & Dennis, R. L. (2011). Effects of nitrogen deposition and empirical nitrogen critical loads for ecoregions of the United States. *Ecol. Appl.*, 21, 3049–3082.

Paulot, F., Henze, D.K., Wennberg, P.O. (2012). Impact of the isoprene photochemical cascade on tropical ozone. *Atmos. Chem. Phys.*, 12, 1307–1325.

Phillips, S.B., Arya, S.P., Aneja, V.P. (2004). Ammonia flux and dry deposition velocity from near-surface concentration gradient measurements over a grass surface in North Carolina. *Atmos. Environ.*, 38, 3469 – 3480.

Pleim, J.E., Bash, J.O., Walker, J.T., Cooter, E. (2013). Development and evaluation of an ammonia bidirectional flux parameterization for air quality models. *J. Geophys. Res.* 118, 3794-3806.

- Prenni, A.J., Levin, E.J.T., Benedict, K.B., Sullivan, A.P., Schurman, M.I., Gebhart, K.A., Day, D.E., Carrico, C.M., Malm, W.C., Schichtel, B.A., Collett, J.L., Kreidenweis, S.M. (2014). Gas-phase reactive nitrogen near Grand Teton National Park: Impacts of transport, anthropogenic emissions, and biomass burning. *Atmos. Environ.* 89, 749–756.
- Pryor, S.C., Barthelmie, R.J., Sørensen, L.L., Jensen, B. (2001). Ammonia concentrations and fluxes over a forest in the midwestern USA. *Atmos. Environ.* 35, 5645–5656.
- Pryor S.C., Barthelmie R.J., Jensen B., Jensen N.O. and Sørensen L.L. (2002). HNO₃ fluxes to a deciduous forest derived using gradient and REA methods. *Atmos. Environ.*, 36, 5993-5999.
- Ratray, G. and Sievering, H. (2001). Dry deposition of ammonia, nitric acid, ammonium, and nitrate to alpine tundra at Niwot Ridge, Colorado. *Atmos. Environ.*, 35, 1105–1109.
- Reis, S., Pinder, R., Zhang, M., Lijie, G., Sutton, M. (2009). Reactive nitrogen in atmospheric emission inventories. *Atmos. Chem. Phys.*, 9, 7657–7677.
- Ren, X., Sanders, J.E., Rajendran, A., Weber, R.J., Goldstein, A.H., Pusede, S.E., Browne, E.C., Min, K.-E., Cohen, R.C. (2011). A relaxed eddy accumulation system for measuring vertical fluxes of nitrous acid, *Atmos. Meas. Tech.*, 4, 2093–2103.
- Rinsland, C.P., Goldman, A., Murcray, F.J., Stephen, T.M., Pougatetchev, N.S., Fishman, J., David, S.J., Blatherwick, R.D., Novelli, P.C., Jones, N.B., Conner, B.J. (1999). Infrared solar spectroscopic measurements of free tropospheric CO, C₂H, and HCN above Mauna Loa, Hawaii: Seasonal variations and evidence for enhanced emissions from the Southeast Asian tropical fires of 1997–1998. *J. Geophys. Res.*, 104, 18667–18680.
- Roberts, J. M. (1990). The atmospheric chemistry of organic nitrates. *Atmos. Environ.*, 24A (2), 243–287.
- Roberts, J.M., Flocke, F., Chen, G., de Gouw, J., Holloway, J.S., Hubler, G., Neuman, J.A., Nicks Jr., D.K., Nowak, J.B., Parrish, D.D., Ryerson, T.B., Sueper, D.T., Warneke, C., Fehsenfeld, F.C. (2004). Measurement of peroxy-carboxylic nitric anhydrides (PANs) during the ITCT 2K2 aircraft intensive experiment. *J. Geophys. Res.*, 109, D23S21.
- Rumsey, I., and Walker, J.T. (2016). Application of an online ion chromatography-based instrument for gradient flux measurements of speciated nitrogen and sulfur. *Atmos. Meas. Tech.*, 9, 2581-2592.
- Schwede, D.B., Lear, G.G. (2014). A novel hybrid approach for estimating total deposition in the United States. *Atmos. Environ.*, 92, 207-220.
- Seinfeld, J.H., Pandis, S. N. (1998). *Atmospheric Chemistry and Physics: From Air Pollution to Climate Change*. John Wiley and Sons.

- Shaw, W.J., Spicer, C.W., Kenny, D.W. (1998). Eddy correlation fluxes of trace gases using a tandem mass spectrometer. *Atmos. Environ.*, 32, 2887–2898.
- Sievering, H., Kelly, T., McConville, G., Seibold, C., Turnipseed, A. (2001). Nitric acid dry deposition to conifer forests: Niwot Ridge spruce-fir-pine study. *Atmos. Environ.*, 35, 3851–3859.
- Sintermann, J., Spirig, C., Jordan, A., Kuhn, U., Ammann, C., Neftel, A. (2011). Eddy covariance flux measurements of ammonia by high temperature chemical ionisation mass spectrometry. *Atmos. Meas. Tech.*, 4, 599–616.
- Sparks, J.P., Walker, J.T., Turnipseed, A., Guenther, A. (2008). Dry nitrogen deposition estimates over a forest experiencing free air CO₂ enrichment. *Glob. Change Biol.*, 14, 1-14.
- Sun, K., Tao, L., Miller, D. J., Zondlo, M. A., Shonkwiler, K. B., Nash, C., & Ham, J. M. (2015). Open-path eddy covariance measurements of ammonia fluxes from a beef cattle feedlot. *Agr. Forest Meteorol.*, 213, 193-202.
- Thom, A. S., Stewart, J. B., Oliver, H. R., Gash, J. H. C. (1975). Comparison of Aerodynamic and Energy Budget Estimates of Fluxes over a Pine Forest. *Q. J. Roy. Meteorol. Soc.*, 101, 93–105.
- Thomas, R. M., Trebs, I., Otjes, R., Jongejan, P. A. C., Brink, H. t., Phillips, G., Kortner, M., Meixner, F. X., Nemitz, E. (2009). An automated analyzer to measure surface-atmosphere exchange fluxes of water soluble inorganic aerosol compounds and reactive trace gases. *Environ. Sci. Technol.*, 43, 1412–1418.
- Thornton J.A., Kercher, J.P., Reidel, T.P., Wagner, N.L., Cozic, J., Holloway, J.S., Dubé, W.P., Wolfe, G.M., Quinn, P.K., Middlebrook, A.M., Alexander, B., Brown, S.S. (2010). A large atomic chlorine source inferred from mid-continental reactive nitrogen chemistry. *Nature*, 464, 271–274.
- Turnipseed, A. A., Huey, L.G., Nemitz, E., Stickel, R., Higgs, J., Tanner, D.J., Slusher, D.L., Sparks, J.P., Flocke, F., Guenther, A. (2006). Eddy covariance fluxes of peroxyacetyl nitrates (PANs) and NO_y to a coniferous forest. *J. Geophys. Res. Atmos.*, 111, D09304.
- Walker, J.T., Dombek, T.L., Green, L.A., Gartman, N., Lehmann, C.M.B. (2012). Stability of organic nitrogen in NADP wet deposition samples. *Atmos. Environ.*, 60, 573-582.
- Wentworth, G.R., Murphy, J.G., Benedict, K.B., Bangs, E. J., Collett, J.L. (2016). The role of dew as a night-time reservoir and morning source for atmospheric ammonia. *Atmos. Chem. Phys.*, 16, 7435-7449.
- Whaley, C. H., Makar, P. A., Shephard, M. W., Zhang, L., Zhang, J., Zheng, Q., Akingunola, A., Wentworth, G. R., Murphy, J. G., Kharol, S. K., Cady-Pereira, K. E. (2018). Contributions of natural and anthropogenic sources to ambient ammonia in the Athabasca Oil Sands and north-western Canada. *Atmos. Chem. Phys.*, 18, 2011-2034.

- Wolfe G.M., Thornton, J.A., Yatavelli, R.L.N., McKay, M., Goldstein, A.H., LaFranchi, B., Min, K.-E., Cohen, R.C. (2009). Eddy covariance fluxes of acyl peroxy nitrates (PAN, PPN and MPAN) above a Ponderosa pine forest. *Atmos. Chem. Phys.*, 9, 615–634.
- Wolfe, G. M., Hanisco, T. F., Arkinson, H. L., Bui, T. P., Crouse, J. D., Dean-Day, J., Goldstein, A., Guenther, A., Hall, S. R., Huey, G., Jacob, D. J., Karl, T., Kim, P. S., Liu, X., Marvin, M. R., Mikoviny, T., Misztal, P. K., Nguyen, T. B., Peischl, J., Pollack, I., Ryerson, T., St. Clair, J. M., Teng, A., Travis, K. R., Ullmann, K., Wennberg, P. O., Wisthaler, A. (2015). Quantifying sources and sinks of reactive gases in the lower atmosphere using airborne flux observations. *Geophys. Res. Lett.*, 42, 8231–8240.
- Wu, Z., Wang, X., Chen, F., Turnipseed, A.A., Guenther, A.B., Niyogi, D., Charusombat, U., Xia, B., Munger, J.W., Alapaty, K. (2011). Evaluating the calculated dry deposition velocities of reactive nitrogen oxides and ozone from two community models over a temperate deciduous forest. *Atmos. Environ.*, 45, 2663–2674.
- Yao, L., Wang, M.-Y., Wang, X.-K., Liu, Y.-J., Chen, H.-F., Zheng, J., Nie, W., Ding, A.-J., Geng, F.-H., Wang, D.-F., Chen, J.-M., Worsnop, D. R., Wang, L. (2016). Detection of atmospheric gaseous amines and amides by a high-resolution time-of-flight chemical ionization mass spectrometer with protonated ethanol reagent ions. *Atmos. Chem. Phys.*, 16, 14527–14543.
- You, Y., Kanawade, V.P., de Gouw, J.A., Guenther, A.B., Madronich, S., Sierra-Hernández, M.R., Lawler, M., Smith, J.N., Takahama, S., Ruggeri, G., Koss, A., Olson, K., Baumann, K., Weber, R.J., Nenes, A., Guo, H., Edgerton, E.S., Porcelli, L., Brune, W.H., Goldstein, A.H., Lee, S.-H. (2014). Atmospheric amines and ammonia measured with a chemical ionization mass spectrometer (CIMS). *Atmos. Chem. Phys.*, 14, 12181–12194.
- Zhang, L., Moran, M., Makar, P., Brook, J., and Gong, S. (2002) Modelling gaseous dry deposition in AURAMS A Unified Regional Air-quality Modelling System. *Atmos. Environ.*, 36, 537–560.
- Zhang, L., Vet, R., O'Brien, J.M., Mihele, C., Liang, Z., Wiebe, A. (2009). Dry deposition of individual nitrogen species at eight Canadian rural sites. *J. Geophys. Res. Atmos.*, 114, D02301.
- Zhang, L., Wright, L.P., Asman, W.A.H. (2010). Bi-directional air-surface exchange of atmospheric ammonia: A review of measurements and a development of a big-leaf model for applications in regional-scale air-quality models. *J. Geophys. Res. Atmos.*, 115, D20.
- Zhang, L., Jacob, D.J., Knipping, E.M., Kumar, N., Munger, J.W., Carouge, C.C., van Donkelaar, A., Wang, Y.X., Chen, D. (2012a). Nitrogen deposition to the United States: Distribution, sources, and processes. *Atmos. Chem. Phys.*, 12, 4539–4554.
- Zhang, N., Zhou, X., Bertman, S., Tang, D., Alaghmand, M., Shepson, P. B., Carroll, M. A. (2012b). Measurements of ambient HONO concentrations and vertical HONO flux above a northern Michigan forest canopy. *Atmos. Chem. Phys.*, 12, 8285–8296.

Zhou, X., Zhang, N., TerAvest, M., Tang, D., Hou, J., Bertman, S., Alaghmand, M., Shepson, P. B., Carroll, M. A., Griffith, S., Dusanter, S., Stevens, P. S. (2011). Nitric acid photolysis on forest canopy surface as a source for tropospheric nitrous acid. *Nat. Geosci.*, 4, 440–443.

Zhu, L., Henze, D., Bash, J., Jeong, G.-R., Cady-Pereira, K., Shephard, M., Luo, M., Paulot, F., Capps, S. (2015). Global evaluation of ammonia bidirectional exchange and livestock diurnal variation schemes. *Atmos. Chem. Phys.*, 15, 12823–12843.

Zöll, U., Brümmer, C., Schrader, F., Ammann, C., Ibrom, A., Flechard, C.R., Nelson, D.D., Zahniser, M., Kutsch, W. (2016). Surface-atmosphere exchange of ammonia over peatland using QCL-based eddy-covariance measurements and inferential modeling. *Atmos. Chem. Phys.*, 16, 11283-11299.

3.1.1.2. Measurements of surface chemistry and wetness relevant to fluxes

Bret A. Schichtel¹ and John T. Walker²

¹National Park Service, Cooperative Institute for Research in the Atmosphere, Colorado State University, Fort Collins, CO

²U.S. EPA, Office of Research and Development, Durham, NC

Research topic summary

The quantification and simulation of the role of surface wetness in the deposition and re-emission of Nr compounds requires a thorough understanding of the composition and volume of the surface wetness. In natural settings, vegetation and ground surfaces become wet from the formation of dew, residual water from precipitation events and guttation. Microscopic wetness layers persist on leaf surfaces even during the day. The presence of this liquid water impacts the mechanisms of air-surface exchange by changing the depositing surface from dry to wet and also adds a temporary reservoir, particularly for soluble compounds. Volatile compounds in the temporary reservoir can be re-emitted back to the atmosphere upon the drying of the surface water.

Previous studies have investigated the impacts on Nr emission and deposition due to surface wetness, but there is a clear need for more studies in this area. Long-term objectives to address this knowledge gap involve expanding current methods for assessing the volume and chemistry of surface wetness to include other chemical compounds; employing these methods to characterize a range of meteorological conditions, vegetation characteristics, atmospheric acidity, and atmospheric NH₃ concentrations; and collocating this detailed surface wetness characterization with air-surface exchange measurements.

Additional measurements of surface wetness will assist in further development of air-surface exchange models, specifically cuticular resistance parameterizations for NH₃. Near-term goals would be to apply measurements of dew volume to test surface moisture predictions in gridded chemical transport models such as CMAQ and to use recent dew chemistry measurements to develop and test more representative parameterizations of cuticular resistance schemes.

Introduction

Wetness of vegetated surfaces can be classified as “macroscopic”, which includes dew, guttation, and precipitation, or “microscopic”, which refers to the thin layer of moisture, invisible to the naked eye, that is maintained on the leaf surface by condensation of transpired water on the cuticle and previously deposited particles (Burkhardt and Hunsche, 2013). While

macroscopic wetness is a diurnal process occurring primarily at night, it is hypothesized that microscopic wetness may exist permanently in some cases and is likely universal across vegetation types (Burkhardt and Hunsche, 2013). Wet surfaces of vegetation are effective sinks for gas phase oxidized and reduced nitrogen and other compounds (Wesely, 1989; Erisman et al., 1994; Cape, 1996; van Hove et al., 1989). Though the data is limited, it has been shown in both laboratory (Takenaka et al., 2009; Wentworth et al., 2016) and field studies (Ellis et al., 2011; Wentworth et al., 2016) that a fraction of semi-volatile solutes (e.g. NH_4^+ and NO_2^-) can be released back into the atmosphere in gas form when the surface dries. The deposition of reactive nitrogen (Nr) compounds to wet surfaces followed by their reemission increases the effective atmospheric lifetime of the Nr compounds, thus changing their spatial and temporal distributions and impacts on atmospheric chemistry and ecosystems to which they deposit. As a temporary reservoir for compounds such as NH_3 that may also reemit as the surface dries, surface wetness may therefore convolute the origin of Nr, the quantifications of which are needed to identify and mitigate Nr deposition issues.

While rain is an important intermittent source of surface wetness, processes of macroscopic wetness relevant to recurring diurnal cycles of air-surface exchange are driven by dew and guttation. Dew is a meteorological phenomenon resulting in the condensation of atmospheric water vapor on leaf surfaces, whereas guttation is a plant physiological process involving the exudation of plant water from the leaf surface. Guttation is chemically diverse, containing a wide range of compounds, including organic acids, base cations and other nutrients, as well as proteins and enzymes (Singh and Singh, 2013) that influence the chemistry of the bulk surface wetness (e.g., dew + guttation). Surface wetness changes Nr deposition by altering the potential deposition surface from a solid surface to a liquid. This affects deposition rates of gases and particles from the atmosphere into the solution and could lead to reemission of volatile compounds upon the solution drying. Some aspects of deposition to wet surfaces are relatively well known. For example, deposition of gases is dependent dependent on the effective Henry's Law coefficient (Wesely, 1989), which depends on the solution pH and thus its chemical composition (Dasgupta and Dong, 1986; Seinfeld and Pandis, 1998). However, understanding of other physiochemical processes important to the dynamics of wetness volume and composition is more limited (Burkhardt and Hunsche, 2013)

Our understanding of the reemissions of volatile ions in a drying surface solution is still developing. As macroscopic wetness evaporates, volatile anions and cations can either remain on the surface as a salt or be emitted into the atmosphere as a gas, with its fate depending on the concentrations of the ions. From a series of laboratory experiments, Takenaka et al., (2009) developed simple relationships illustrating that the fraction of the volatile ions emitted was dependent on the ratio of the difference between non-volatile cations and anions and the volatile ion concentrations. The total mass reemitted and its rate were then dependent on the volume of the surface wetness and rate of drying. Wentworth et al. (2016) recently demonstrated the role of dew as a temporary reservoir for NH_3 by measuring its volume and ion balance along with the dynamics of wetting and drying of the surface in relation to

atmospheric NH₃ concentrations in a grass field. At their site, dew composition suggested that nearly all of NH₄⁺ in the dew was emitted to the atmosphere as NH₃ during evaporation. An important implication of their work is that NH₃ deposited to the wet surface at night does not necessarily remain in the ecosystem.

The volume of macroscopic surface wetness and its composition are also not well understood. The volume of the surface wetness depends on the characteristics of the canopy, radiative cooling, and specific humidity, all of which will vary with the level within the canopy. The measurement of surface liquid volume is also difficult and subject to larger errors (Bash et al., 2010; Burkhardt et al., 2009; Walker et al., 2013). Provided that sufficient quantities of sample can be collected, assessing the composition of the surface wetness is straight forward; however, there are few field experiments measuring the composition of the surface wetness. This includes a study by He et al., (2006) that speciated dew collected in a rural forested area in Michigan; Burkhardt et al., (2009) that speciated dew, guttation, and rain from leaves in a managed grassland canopy; Walker et al., (2013) that measured the composition of dew and guttation in a fertilized *Zea mays* canopy; and Wentworth et al., (2016) that speciated dew and rain on an artificial surface in Rocky Mountain NP, Colorado.

The quantification and simulation of the role of surface wetness in the deposition and redistribution of Nr compounds requires a thorough understanding of the composition and volume of the surface wetness. This depends on the ambient concentrations of the particulate matter and gasses as well as the contributions and modification of constituents from the surfaces the water is on. While our current knowledge of the processes of deposition to wet surfaces is reasonably advanced for some species (e.g., Massad et al., 2010 for NH₃), additional research is needed. For example, modifications to the wetness composition due to the biological and physical characteristics of the underlying surface and the chemical dynamics during drying of the surface are not well understood. To resolve this information gap, there is a need to measure the wetness and its chemistry on a number of different surfaces including different vegetation types, layers within a canopy and soil and duff layers.

State of the Science

Measurements of Surface Chemistry and Reemission

In a series of laboratory experiments, Takenaka et al., (2009) found that in acidic solutions, the total concentration of non-volatile anions was higher than that of non-volatile cations and the excess volatile anions combined with protons and evaporated such that the fraction of a volatile anion [X⁻] emitted into the atmosphere could be explained by:

$$Fraction (X^-) = \frac{[X^-] - (\sum[\text{nonvolatile anion}] - \sum[\text{nonvolatile cation}])}{[X^-]} \quad (1)$$

In their work, the nonvolatile cations include Na⁺, K⁺, Ca²⁺, and Mg²⁺, and the nonvolatile anions include SO₄²⁻, NO₃⁻, and Cl⁻. The volatile anions include NO₂⁻, formate, and acetate and the units are in equivalence.

In alkaline solutions, they found that total concentration of non-volatile cations was higher than that of non-volatile anions and excess volatile cations combined with OH⁻ and evaporated such that the fraction of a volatile cation [Y⁺] emitted into the atmosphere could be explained by:

$$Fraction (Y^+) = \frac{[Y^+] - (\sum[\text{nonvolatile anion}] - \sum[\text{nonvolatile cation}])}{[Y^+]} \quad (2)$$

For solution containing ammonium (NH₄⁺) they found a similar relationship:

$$Fraction (NH_4^+) = \frac{[NH_4^+] - (\sum[\text{nonvolatile anion}] - \sum[\text{nonvolatile cation}])}{[NH_4^+]} \quad (3)$$

Wentworth et al., (2016) tested the validity of the reemission of ammonia, as described by equation 3, by generating and drying synthetic dew doped with concentrations expected in the natural environment and found very good agreement between experimental and theoretical results. However, they found that acetate, formate and bicarbonate form non-volatile salts upon evaporation when there was an excess of cations, and they needed to be included in the sum of non-volatile anions.

There have been several field studies that measured the composition of macroscopic surface wetness (He et al., 2006; Burkhardt et al., 2009; Rubio et al., 2009; Rubio et al., 2012; Walker et al., 2013). However, these studies did not simultaneously measure wetness volume and ambient concentrations or the measurement of wetness volume had large errors.

Consequently, the mass of the ions in solution could not be accurately estimated resulting in uncertain estimates of deposition and emission rates. In addition, salts on the wetted surface and their influence on the concentrations could not be assessed.

One exception was the study by Wentworth et al., (2016) in which a dew collector was developed to accurately measure dew volumes and concentrations and measurements were conducted at relevant ambient concentrations. However, the dew collector employed a synthetic surface and so did not account for the additions of ions from existing salts present on natural vegetation and other surfaces. In addition, the dew collector was physically representative of grass, but not forested canopies, or soil and duff layers. Lastly, the study focused only on NH₃ and NH₄⁺.

Modeling of NH₃ Fluxes of Wet Surfaces

Within the bidirectional modeling framework, NH₃ deposition to wet vegetation surfaces is typically estimated via a relative humidity dependent cuticular resistance (Massad et al., 2010). In the model recommended by Massad et al. (2010), parameterization of the cuticular resistance (R_w) to NH₃ deposition accounts for the degree of surface wetness and the acidity of the surface liquid. The minimum cuticular resistance is quantified as the molar ratio of atmospheric concentrations of inorganic acid gases (SO₂, HNO₃, HCl) to NH₃. This parameterization can be driven by routine meteorological and atmospheric chemistry measurements and balances mechanistic representation of the exchange process with computational efficiency suitable for chemical transport models.

In the Massad et al. (2010) parameterization, only deposition to the cuticle is treated, i.e., there is no emission from the cuticle. The process of NH_3 reemission associated with drying of the surface is not explicitly represented, though attempts have been made to model the process as a dynamic bi-directional cuticular flux (Sutton et al., 1998) based on the idea of the cuticle being a capacitor. In this framework, NH_3 can be adsorbed or emitted from the cuticle depending on the amount of moisture and its Henry's law equilibrium. The early work of Sutton et al. (1998) was extended by Flechard et al. (1999) to include explicit modeling of the H^+ and NH_4^+ concentrations of the surface moisture layer. In their framework, the NH_3 compensation point (χ_d) of the surface liquid is linked to a bi-directional cuticular flux via the canopy compensation point (χ_c) and the wet cuticular resistance (R_d), which is a function of the liquid chemistry, including dissolved CO_2 , SO_2 , O_3 , HNO_2 , HNO_3 , and HCl as well as their air-surface exchange and aqueous reactions (e.g., SO_2 oxidation by O_3). Transcuticular exchange of base cations, H^+ and NH_4^+ are also represented. The model is initialized using measurements of the chemistry of dew, guttation, and rainfall (pH , NH_4^+ , K^+ , Na^+ , Ca_2^+ , Mg^{2+} , Cl^- , NO_3^- , and SO_4^{2-}). Burkhardt et al. (2009) have implemented the dynamic chemistry model of Flechard et al. (1999) within the resistance-based two-layer (ground + foliage) compensation point model of Nemitz et al. (2001).

Future Research

Characterization of Air-Surface Exchange

There is a lack of field measurements to assess the deposition and reemission of Nr compounds in surface wetness in natural ecosystems. The work by Wentworth et al., (2016) is promising and demonstrates a method to assess the atmospheric inputs into surface wetness and its fate. In the short term, more studies similar to Wentworth et al (2016) are needed for a range of vegetation characteristics, atmospheric acidity, and atmospheric NH_3 concentrations. Coupling of experiments investigating dew formation and chemistry with high temporal resolution measurements of NH_3 air concentrations and fluxes is needed to assess the role of surface wetness in the net flux of NH_3 into and out of the ecosystem on time scales of days to weeks. In the long term, easily-implemented methods are needed to measure the volume of macroscopic surface wetness in more complex settings (i.e., forests) and to characterize its ionic composition. Studies which assess the relative importance of dew versus guttation with respect to chemistry and wetness volume, and relationships between wetness dynamics and plant physiology are also needed (Hughes and Brimblecome, 1994). Measurements of dry deposition of compounds such as SO_2 and HNO_3 that affect the acidity of the exchange surface would also be helpful.

Linkage to Cuticular Resistance Models

The results of Wentworth et al. (2016) reinforce the need for continued evolution of the bidirectional NH_3 modeling framework to include cuticular emission (Sutton et al, 1998). Ignoring computational intensity, the primary challenge to further advancement of the dynamic wetness chemistry models of Flechard et al. (1999) and Burkhardt et al. (2009) is a lack of

observational data needed to initialize and test the models. Current efforts rely on measurements of the bulk chemistry of relatively large droplets collected at night and early morning or after rain events. Studies of dew chemistry and reemission of volatile compounds should consider the modeling framework of Burkhardt et al. (2009) and, to the extent practical, include chemical analyses that will allow for extension of the results to this cuticular modeling framework.

In addition to better understanding exchange with dew/guttation, a more complete understanding of the chemistry and dynamics of microscopic surface moisture, and its relation to the daytime cuticular resistance, is also needed (Flechard et al., 2013; Burkhardt and Hunsche, 2013). Collecting temporal information on chemistry as macroscopic wetness becomes more concentrated during morning evaporation would help to inform the characteristics of cuticle surfaces in the absence of dew/guttation. Tools for directly examining the chemistry of microscopic moisture layers under field conditions are needed. As noted by Flechard et al. (2013) in a recent review of NH₃ bidirectional exchange models, in the absence of field measurements laboratory experiments employing environmental microscopy (e.g. Burkhardt et al., 2012) may be informative. Advancement of the bidirectional cuticle flux model and its adaptation for CTMs represent long term goals. In the near term, measurements of dew volume and chemistry will facilitate the testing of surface moisture predictions and more representative parameterization of cuticular resistance schemes used in gridded chemical transport models (e.g., Pleim et al., 2013; Zhang et al., 2010). Development of climatologies of surface wetness (Klemm et al., 2002) would be extremely helpful in this regard.

References

- Bash, J. O., Walker, J. T., Katul, G. G., Jones, M. R., Nemitz, E., Robarge, W. P., 2010. Estimation of in-canopy ammonia sources and sinks in a fertilized *Zea mays* field. *Environmental Science and Technology*, 44, 1683–1689.
- Burkhardt, J., Flechard, C.R., Gresens, F., Mattsson, M., Jongejan, P.A.C., Erisman, J.W., Weidinger, T., Meszaros, R., Nemitz, E., Sutton, M.A., 2009. Modelling the dynamic chemical interactions of atmospheric ammonia with leaf surface wetness in a managed grassland canopy. *Biogeosciences*, 6, 67-84.
- Burkhardt, J., Basi, S., Pariyar, S., Hunsche, M., 2012. Stomatal penetration by aqueous solutions—an update involving leaf surface particles. *New Phytologist*, 196, 774–787.
- Burkhardt, J., Hunsche, M., 2013. “Breath figures” on leaf surfaces—formation and effects of microscopic leaf wetness. *Frontiers in Plant Science*, 4, 422.
- Cape, J.N., 1996. Surface wetness and pollutant deposition. In: *Plant cuticles*. Ed. G. Kierstiens. BIOS Scientific Publishers, Oxford.

Dasgupta, P.G., Dong, S., 1986. Solubility of ammonia in liquid water and generation of trace levels of standard gaseous ammonia. *Atmospheric Environment*, 20, 565–570.

Ellis, R. A., Murphy, J. G., Markovic, M. Z., VandenBoer, T. C., Makar, P. A., Brook, J., Mihele, C., 2011. The influence of gas-particle partitioning and surface-atmosphere exchange on ammonia during BAQS-Met. *Atmospheric Chemistry and Physics*, 11, 133–145.

Erismann, J.W., van Pul, A., Wyers, P., 1994. Parameterization of surface resistance for the quantification of atmospheric deposition of acidifying compounds and ozone. *Atmospheric Environment*, 28, 2595-2607.

Flechard, C.R., Fowler, D., Sutton, M.A., Cape, J.N., 1999. A dynamic chemical model of bi-directional ammonia exchange between semi-natural vegetation and the atmosphere. *Quarterly Journal of the Royal Meteorological Society*, 125, 2611–2641.

Flechard, C. R., Massad, R.-S., Loubet, B., Personne, E., Simpson, D., Bash, J. O., Cooter, E. J., Nemitz, E., & Sutton, M. A., 2013. Advances in understanding, models and parameterizations of biosphere-atmosphere ammonia exchange. *Biogeosciences*, 10, 5183–5225.

He, Y., Zhou, X., Hou, J., Gao, H., Bertman, S. B., 2006. Importance of dew in controlling the air-surface exchange of HONO in rural forested environments. *Geophysical Research Letters*, 33, L02813, doi:10.1029/2005GL024348.

Hughes, R. N. and Brimblecombe, P., 1994. Dew and guttation – formation and environmental significance. *Agr. Forest Meteorol.*, 67, 173–190.

Klemm, O., Milford, C., Sutton, M.A., Spindler, G., van Putten, E., 2002. A climatology of leaf surface wetness. *Theoretical and Applied Climatology*, 71, 107-117.

Massad, R.-S., Nemitz, E., Sutton, M.A., 2010. Review and parameterisation of bi-directional ammonia exchange between vegetation and the atmosphere. *Atmospheric Chemistry and Physics*, 10, 10359–10386.

Nemitz, E., Milford, C., Sutton, M.A., 2001. A two-layer canopy compensation point model for describing bi-directional biosphere-atmosphere exchange of ammonia. *Quarterly Journal of the Royal Meteorological Society*, 127, 815–833.

Pleim, J.E., Bash, J.O., Walker, J.T., Cooter, E., 2013. Development and evaluation of an ammonia bidirectional flux parameterization for air quality models. *Journal of Geophysical Research-Atmospheres* 118, 3794-3806.

Rubio, M.A., Lissi, E., Villena, G., Elshorbany, Y.F., Kleffmann, J., Kurtenbach, R., Wiesen, P., 2009. Simultaneous measurements of formaldehyde and nitrous acid in dew and gas phase in the atmosphere of Santiago, Chile. *Atmospheric Environment*, 43, 6106–6109.

Rubio, M.A., Lissi, E., Herrera, N., Pérez, V., Fuentes, N., 2012. Phenol and nitrophenols in the air and dew waters of Santiago de Chile. *Chemosphere*, 86, 1035–1039.

Seinfeld, J. H., Pandis, S. N., 1998. *Atmospheric Chemistry and Physics from Air Pollution to Climate Change*. New York. John Wiley and Sons, Incorporated.

Singh, S., Singh, T.N., 2013. Guttation 1: chemistry, crop husbandry, and molecular farming. *Phytochemistry Reviews*, 12, 147 – 172.

Sutton, M.A., Burkhardt, J.K., Guerin, D., Nemitz, E., Fowler, D., 1998. Development of resistance models to describe measurements of bi-directional ammonia surface-atmosphere exchange. *Atmospheric Environment*, 32, 473–480.

Takenaka, N., Takayama, K., Ojio, N., Shimazaki, W., Ohira, K., Soda, H., Suzue, T., Sadanaga, Y., Bandow, H., Maeda, Y., 2009. The chemistry of drying an aqueous solution of salts. *Journal of Physical Chemistry A*, 113, 12233-12242.

Walker, J.T., Jones, M.R., Bash, J.O., Myles, L., Meyers, T., Schwede, D., Herrick, J., Nemitz, E., Robarge, W., 2013. Processes of ammonia air-surface exchange in a fertilized Zea mays canopy. *Biogeosciences*, 2, 981-998.

Wentworth, G.R., Murphy, J.G., Benedict, K.B., Bangs, E.J., Collett, J.L., 2016. The role of dew as a night-time reservoir and morning source for atmospheric ammonia. *Atmospheric Chemistry and Physics*, 16, 7435-7449.

Wesely, M., 1989. Parameterization of surface resistances to gaseous dry deposition in regional-scale numerical models. *Atmospheric Environment*, 23, 1293–1304.

Zhang, L., Wright, L.P., Asman, W.A.H., 2010. Bi-directional air-surface exchange of atmospheric ammonia: A review of measurements and a development of a big-leaf model for applications in regional-scale air-quality models. *Journal of Geophysical Research – Atmospheres*, 115, D20310.

3.1.1.3. Advancing throughfall methods for quantifying Nr deposition

Michael D. Bell¹, Mark E. Fenn², Leiming Zhang³, Kristi H. Morris¹

¹National Park Service, Air Resources Division, Lakewood, CO

²USDA Forest Service, Pacific Southwest Research Station, Riverside, CA

³Environment and Climate Change Canada, Air Quality Research Division, Toronto, ON, Canada

Research topic summary

Due to their relative simplicity and low-cost relative to other deposition methods, throughfall measurements are widely used by the ecological community to quantify Nr deposition at seasonal and annual time scales. These collectors are often used to measure local scale deposition patterns and compare observed gradients to pollution sources and changing ecosystem components. As the use of throughfall data for ecological assessments continues to expand, there is a need to better define the operational characteristics of throughfall sampling techniques in different ecosystems, adapt collection and analytical methods to capture a broader suite of Nr compounds, and understand the comparability of throughfall measurements to deposition estimates derived from chemical transport models.

Regarding the development of throughfall methods, a near-term goal is to develop a database of throughfall measurements, using both conventional and ion exchange resin (IER) methods, that can be compared across ecosystems to better understand accuracy and consistency. In the longer term, additional analytical techniques are needed to measure dissolved organic Nr (DON) by IER to capture the full inorganic/organic N budget. Concurrent measurements of throughfall Nr and bulk Nr deposition, and total canopy Nr flux measurements are needed in order to develop empirical conversion factors for relating throughfall to total Nr deposition. As a first step, these empirical relationships could be examined by comparing throughfall to total deposition budgets comprising wet deposition plus site specific estimates of dry deposition derived from inferential models. To understand the relationships between throughfall measurements and total deposition from gridded chemical transport models, a near-term objective is to use the throughfall database described above for measurement-model comparisons. Longer-term comparisons will require more comprehensive measurement datasets that capture model sub-grid variability and explicitly resolved wet and dry deposition components.

Introduction

Atmospheric Nr is deposited to the earth's surface via wet and dry processes. Wet deposition occurs when pollutants dissolved in water are deposited to the landscape via precipitation (rain, snow, and fog). Dry deposition occurs when pollutants (as gases or particles) settle, impact, and adsorb onto landscape surfaces. Ecosystem components respond to total Nr loading so it is important to quantify both wet and dry deposition. Increases in Nr deposition can cause shifts to ecosystem processes such as surface water enrichment (Rhodes et al. 2017), spread of invasive plant species (Rao and Allen 2010), and shifts in soil microbial communities (Allen et al. 2016). Many sensitive ecosystems are located in remote areas with no electricity, making throughfall sampling systems the most viable option for measuring Nr inputs.

Throughfall sampling is a widely used method to measure the mass inputs of ions (e.g., NO_3^- , NH_4^+ , SO_4^{2-} , and base cations) from the atmosphere to the ecosystem, through precipitation under a canopy of vegetation. Throughfall incorporates wet and dry deposition as the ions that have accumulated on the vegetative surfaces are washed into the sampler by precipitation (Draaijers et al. 1996, Bleeker et al. 2003, Fenn and Poth 2004, Hansen et al. 2013, Clarke et al. 2016). Throughfall is generally collected by a funnel that directs the sample into a collection container and is calculated in $\text{kg ha}^{-1} \text{ yr}^{-1}$ based on the diameter of the funnel, ion concentration, and the volume of ionic solution. These samplers have also been used in open, canopy-free sites to collect bulk deposition (i.e. wet deposition and a portion of dry deposition). Throughfall and bulk measurements provide a low-bound estimate of wet and dry deposition of inorganic Nr at a specific site. They provide a low-cost alternative to active deposition collectors that require electricity and weekly visits. When IER deposition collectors are used, this allows the collectors to be placed in more remote locations for extended periods of time with infrequent sample collection visits (Fenn et al., 2018).



Figure 1. (A) Throughfall collector with resin tube covered with a protective "shade" tube. (B) A conventional throughfall collector in a forest in Millbrook, NY. Pictures courtesy of United States Forest Service and Cary Institute of Ecosystem Studies.

CTMs are also widely used to estimate deposition across the country based on emissions, meteorology, chemical transformation, and transport. The most commonly used CTMs in the U.S. are the Comprehensive Air Quality Model with Extensions (CAMx) and The Community Multiscale Air Quality modeling system (CMAQ). Modeled output from CMAQ is used in the Total Deposition measurement-model fusion method (TDep) to estimate total deposition across the U.S. TDep improves on CMAQ estimates by weighting modeled values based on measurements of deposition from standardized networks (Schwede and Lear 2014). Throughfall and bulk measurements can be used to evaluate the accuracy and consistency of modeled deposition estimates; however, comparing site specific data to modeled output for a grid (4-12km) is challenging due to the ecological and geological diversity that exists within the grid cell. In order to scale up from a single collector to a grid cell, or down from a grid cell to a collector, it is necessary to further characterize throughfall methods to assess collection efficiency and performance across canopy types and deposition regimes and to develop a method for relating throughfall to modelled deposition output.

State of the science

Throughfall methods

Throughfall deposition measures the mass input of atmospheric ions to the forest floor under a vegetation canopy. There are two main types of throughfall deposition collectors: 1) conventional throughfall samplers that collect precipitation or throughfall solutions which are analyzed for ion concentration. Deposition is calculated using volume and concentration (Lovett and Lindberg 1993). 2) IER columns that allow precipitation to pass through the column, capturing ions from solution for future extraction and analysis (Fenn and Poth 2004). Deposition is calculated based on the total number of ions collected on the resin and is not based on sample volume. Both methods create time-averaged samples based on the exposure duration. Funnel openings are recommended to be at least 20 cm in diameter and have vertical sidewalls to maximize the efficiency of collection (Bleeker et al. 2003, Clarke et al. 2016).

IER collectors represent a significant logistical and cost savings over conventional throughfall collectors due to the cost associated with collecting and analyzing samples frequently. Conventional sampling is estimated to be 6-7 times more expensive than the IER method (Fenn et al., 2018), but does provide a finer scale temporal resolution of deposition events that may be impacting ecological processes. Conventional samplers must be checked at least every two weeks or on a precipitation event basis to reduce microbial contamination, which can lead to nitrogen transformation (Watanabe et al. 2016), and prevent overflow of collection containers after high levels of precipitation. Alternatively, IER collectors are effective from 3 to 12 months (as long as precipitation is occurring), and may be used longer if needed (Fenn and Poth 2004). The longer the period of exposure, there is both the potential for less uncertainty of measurements due to the cumulative collection of a sample, but also the increased risk of contamination or damage to the collector.

Throughfall collectors are best paired with bulk collectors located in an open area to compare impacts of the canopy on bulk deposition. This can be challenging, because these need to be placed in a clearing large enough to avoid contamination from blow-off from trees during storm events (Clarke et al. 2016). Such clearings are not always available for collocated sets of collectors.

Both types of collectors may be contaminated by animal activity, but contamination of IER collectors is more significant due to the average length of exposure. To minimize bird contamination, funnels are modified to prevent birds from perching on the edge of the funnels, which allows them to defecate into the funnel and contaminate the sample. This is most important in canopy free areas, due to the collector being the highest perch, but can also poses a risk under a canopy depending on the site characteristics. Bird rings consist of a metal ring with a wider diameter than the funnel, and possibly crisscrossed with fishing wire, to allow birds to perch outside the funnel and reduce the risk of sample contamination.

Once the samples are collected, they are analyzed for ion content. In addition to Nr species, measuring phosphate (PO_4^{3-}) allows for recognition of fecal contamination. Throughfall deposition is calculated for conventional collectors by using the area of the funnel, volume of the sample, and concentration of the sample. Deposition fluxes are calculated with IER collectors based on the area of the funnel opening and the mass of ions extracted from the IER columns. Ion mass is determined from the volume and ionic concentration of the column extractant. Measurements of base cation deposition can also be important for acidification studies (Fenn et al. 2015). Dissolved organic nitrogen (DON) can make up a significant portion of deposition, but is often not taken into account when calculating deposition (Cornell 2011). DON measurements can be made with conventional throughfall collectors, but methods have not been developed to extract DON from IER columns.

One additional use of the sample is analysis for natural abundance isotopes that can be used to identify emission sources of Nr (Hastings et al. 2003, Elliott et al. 2009). Throughfall measurements can be used to identify sources of Nr and sulfur (S) collected (Nanus et al. 2008, Templer and Weathers 2011, Clow et al. 2015). The measurements, like the dissolved inorganic Nr (DIN) levels, are composite samples for the exposure period. The shorter the exposure, the more refined the source apportionment can be, but the lower amount of Nr available for analysis. This has the potential to differentiate sources of Nr and how the canopy impacts throughfall by measuring the isotopic signature on a vertical gradient (Heaton et al. 1997, Templer et al. 2015).

Table 1. Comparison of conventional and IER throughfall collection methods.

Collector Type	IER Column	Conventional Collector
Nr collected from	IER beads	Precipitation solution

Average Frequency of Collection	6 months (up to a year)	2 Weeks (up to a month with antimicrobial treatment)
Average Sampling periods per year	2	Multiple, based on precipitation events
Time Sensitive	No	Yes
Isotope Analysis	Yes, cumulative	Yes
DON analysis	No	Yes
Potential Contamination	Birds/Rodents	Birds/Microbes
Cost per sampler¹	\$248	\$1605

¹- Cost per deposition sampler includes the following: laboratory and field supplies including collector parts, laboratory analysis costs, vehicle and travel costs, and labor costs. Assumes two 6-month exposures for the IER samplers and 22 sampling events for the conventional samplers. Is based on 15 replicate deposition samplers.

Deposition processes

How can we better understand the relationships between throughfall measurements and deposition processes, e.g. canopy interactions?

To a large degree, the interactions of atmospheric Nr with canopies is a black box, with only a crude quantitative understanding of interactions. The fraction of atmospheric Nr that is retained in the canopy varies with species, environmental conditions, stand height, and stand age. After being deposited to the canopy, nitrogenous pollutants are either taken up by the tree, washed off from canopy surfaces by precipitation and deposited directly to the ground, or are transported via stemflow, the movement of precipitation and dissolved pollutants down tree branches and trunks to the base of the tree (Levia et al. 2011). Generally, less than 10% of total deposition is from stemflow, but varies by species, and can be as much as 40% in some areas (Draaijers et al. 1996). Gaseous compounds can be taken up internally by stomata and not accounted for in throughfall unless some of such Nr is subsequently leached out. But gaseous Nr also interacts with canopy surfaces and presumably much of it that interacts with water layers on needles is adsorbed to such surfaces and is washed off in throughfall. These effects can be enhanced with the presence of epiphytic species (i.e. species that grow on a plant surface but obtain nutrients and moisture from the atmosphere), in the canopy (Van Stan li and Pypker 2015), which increases the surface area and the gas exchange with the atmosphere.

To characterize the dynamic exchange of chemicals between the atmosphere and the surface of the ecosystem, canopy-scale fluxes are quantified directly using micrometeorological techniques involving the measurement of air concentrations and turbulence above the canopy. The data allow for rates of emission and deposition to be calculated alongside atmospheric

processes such as wind, surface wetness, and temperature clarifying processes by which pollutants flow through the system. Due to the size and cost of the canopy-flux measurement system, they are generally limited to a single site in an area. Also, because they require electricity, they are not able to be set up in remote locations. Therefore, there is a need to collocate throughfall samplers alongside flux towers in different ecosystems to better understand the relationships between the canopy scale fluxes and throughfall samples. In addition, vertical distribution of throughfall collectors within the canopy would allow for spatial correlation between canopy exchanges to throughfall deposition (Adriaenssens, 2012).

How representative are throughfall measurements with respect to completeness of the wet+dry deposition budget and spatial variability?

Due to the factors described above, throughfall deposition estimates are a low-end estimate of the wet+dry deposition budget. Throughfall deposition estimates change with distance from forest edges, as N_r is scrubbed from the atmosphere as it passes through the forest, with edges likely having higher throughfall deposition (Devlaeminck et al. 2005, Templer et al. 2015). Variation both within a vegetation species based on canopy height and leaf density and between species can alter the amount of deposition retained in the canopy and that which reaches the forest floor (Nordén 1991, Robertson et al. 2000). Thus, heterogeneity in tree canopy cover can lead to variation in throughfall deposition collected which needs to be taken into account when scaling up (Levia and Frost 2006).

Local climate also impacts the accuracy of deposition estimates. Throughfall collectors are less effective in areas with extended dry periods (e.g. deserts, southern California mountains) because a higher percentage of ion flux is through dry deposition and there aren't enough precipitation events to wash it into the collection basin (Fenn and Poth 2004). Funnels are also a poor dry deposition surface due to the material, color, and the fact that they do not mimic the texture of any natural feature. In wet, cold areas, where significant precipitation falls as snow, the collection efficiency of snow tubes that are inserted into funnels, likely underestimates deposition due to inefficient snow collection, especially during windy conditions (Fenn et al. 2015). Due to this, Clow et al. (2015) recommend pairing summer throughfall collection with winter snowpack sampling to avoid collection efficiency issues and better estimate the total N_r load. However, this approach is only feasible at high elevation sites with a persistent winter snowpack.

Due to these factors influencing the variability of ion flux, the number of collectors needed will vary by site based on the data quality objectives of the study, ions of interest, and the time period of analysis (Houle et al. 1999). The collector number will likely vary by the type of canopy cover, the amount of precipitation, the likelihood of contamination, but most commonly, the number of collectors is determined by the amount of resources available. In the European ICP Forests network the most common number of collectors deployed per study site was 10, with replicates ranging from 8 to 20 samplers per plot in various countries (Bleeker et al. 2003). For more intensive deposition studies (e.g. individual precipitation events) greater

numbers of IER samplers can be deployed (Houle et al. 1999), with up to 36 samplers in a 4000 m² area (Fenn et al. 2013). However, it should be noted that fewer replicate samplers are needed for monitoring cumulative deposition compared to studies comparing ionic concentrations in conventional throughfall samplers.

How comparable are throughfall measurements with CTM estimates?

Comparisons between throughfall deposition measurements and CTMs show variable accuracy and present the challenge of integrating annual measurements of a 20 cm vertical column of a complex ecosystem with the average modeled deposition of a 4 km (or larger) grid cell (Schwede and Lear 2014). Steep environmental gradients within a cell can lead to overestimation of deposition, such as precipitation increases with elevation (Williams et al. 2017). The complexity of the land cover types within a model grid cell can also impact accuracy as open and closed canopy systems will have vastly different deposition values but are averaged within the model. In these instances, having both bulk and throughfall deposition within the same cell can help correct the estimates. Additionally, these comparisons can be made more accurate by (1) comparing modeled total Nr (from both gases and ions) deposition with throughfall measurement for wet periods only, and (2) comparing modeled particulate deposition (excluding gaseous pollutants) with throughfall measurements from longer periods (e.g., monthly or longer).

Future research

Additional research is needed to address canopy interactions influencing deposition measurements, scaling throughfall measurements up to forests and communities, and variability of throughfall deposition in different ecoregions.

Throughfall methods

Issues that need to be addressed in regard to throughfall monitoring of Nr deposition include quantification and mechanisms of canopy Nr uptake, thus increasing the capacity to relate throughfall Nr deposition to total (wet, dry, cloudwater) deposition of Nr. Throughfall deposition generally underestimates total deposition due to canopy retention of Nr compounds either through stomatal uptake (Sparks, 2009), or retention of Nr by canopy surfaces, microbes or epiphytes (Avila et al. 2017, Guerrieri et al. 2015). Such canopy retention can occur from atmospheric Nr that is dry-deposited or deposited as fog/cloudwater or as precipitation or snow (Fenn et al. 2013, Lovett and Lindberg 1993, Templer et al. 2015).

In the near-term, throughfall collectors need to be compared among different ecosystems for accuracy and consistency, including how percentage of dry deposition (e.g., see Fenn et al. 2013) affects collection efficiency. An initial step for this need, which can be accomplished in the near term, is to develop a database of throughfall measurements using both conventional and IER methods. This will leverage existing data for regional and national comparisons of

measurement collection under various tree species and environmental conditions while understanding local variation among collectors.

A longer-term goal is to develop additional analysis techniques to measure DON from IER columns. A standardized technique is needed for DON capture and analysis with IER collectors in order to understand if such methods are able to integrate long term deposition of organic and inorganic Nr deposition.

Converting throughfall Nr fluxes to total Nr deposition

Canopy uptake and Nr retention can change across forest types and geographic regions, illustrating the need to develop multiple semi-quantitative (empirical) formulations linking throughfall, dry, and wet deposition under typical canopy and precipitation conditions to best estimates of actual total Nr deposition. In other words, forest and climatic region-specific empirical conversion factors are likely needed for relating throughfall to canopy-scale flux measurements. A near-term goal would be to measure air concentrations and then estimate dry deposition using the inferential method to provide a total dry deposition budget, which, after adding wet deposition collected in open space, will then provide an estimated total Nr deposition budget (Bytnerowicz et al. 2015). This can then be used to compare with throughfall measurements and for further developing empirical formulas mentioned in this section. A long-term goal will include concurrent measurements of throughfall Nr and bulk Nr deposition, and total canopy Nr flux measurements in order to develop the empirical conversion factors for relating throughfall to total Nr deposition. In addition, fluxes of Nr in stemflow can also be measured for a more complete budget, although the relative importance of stemflow to total Nr deposition varies widely among forest species. Developing this measurement regime across multiple sites with different tree species and contrasting environments would allow for a comparison between deposition rates relative to species and location and get a better estimate of missing dry deposition.

Comparing measured and modeled values

Once throughfall values have been converted to total Nr deposition at monitoring sites, the estimated total Nr deposition fluxes will need to be scaled up from a local measurement to regions/grid cells. This will allow for better comparisons between measurement and modeled values in different ecosystems. Up or downscaling either measured or modeled values will add a measure of uncertainty, because modelling approaches are mechanistically driven and applied at broad spatial scales, even though the complex mechanisms involved are imperfectly understood. In contrast, empirical measurements ignore the processes and mechanisms driving atmospheric deposition and only measure deposition fluxes at discrete sampling points. Understanding how a point measurement relates to the surrounding area is important to accurately establish critical load and critical load exceedance values on finer scales for improved analysis of environmental response.

An initial step will compare CTM grid estimates to site-specific inferential estimates. This model to model comparison, integrates site specific measurements from the inferential estimates to develop a regional comparison to the CTM. The error associated with the measurements may then be able to be used to understand differences between throughfall measurements and the CTMs when analyzing the throughfall measurement database described above. This can provide an awareness of whether measurements in certain areas are more similar and if new measurement protocols need to be developed for others. From the modeling perspective, downscaling deposition outputs to the land cover type will provide a more accurate representation of deposition over the throughfall collector location.

Longer-term steps will be to characterize the variation of deposition under the diverse species assemblage of the forest. Understanding changes in throughfall from one species to the next will allow for more accurate parameterization using different land-use or vegetation-type assessment methods (e.g. forest models, land-use databases, or satellite imagery) and improve estimates of deposition loads for specific forests or grid cells that may be comprised of both forest and open-space (Wilson et al. 2012). In the case of the latter, pairing throughfall with bulk measurements where possible would be helpful in calculating the canopy contribution to the deposition load.

References

- Adriaenssens, S., K. Hansen, J. Staelens, K. Wuyts, A. De Schrijver, L. Baeten, P. Boeckx, R. Samson, and K. Verheyen. 2012. Throughfall deposition and canopy exchange processes along a vertical gradient within the canopy of beech (*Fagus sylvatica* L.) and Norway spruce (*Picea abies* (L.) Karst). *Science of the Total Environment* 420:168-182.
- Allen, E. B., L. M. Egerton-Warburton, B. E. Hilbig, and J. M. Valliere. 2016. Interactions of arbuscular mycorrhizal fungi, critical loads of nitrogen deposition, and shifts from native to invasive species in a southern California shrubland. *Botany* 94:425-433.
- Avila, A., Aguilhaume, L., Izquieta-Rojano, S., García-Gómez, H., Elustondo, D., Santamaría, J. M. and Alonso, R. 2017. Quantitative study on nitrogen deposition and canopy retention in Mediterranean evergreen forests. *Environ. Sci. Pollut. Res.* 24: 26213-26226.
- Bleeker, A., G. Draaijers, D. van der Veen, J. W. Erisman, H. Möls, P. Fonteijn, and M. Geusebroek. 2003. Field intercomparison of throughfall measurements performed within the framework of the Pan European intensive monitoring program of EU/ICP Forest. *Environmental Pollution* 125:123-138.
- Brooks, P. D., M. W. Williams, and S. K. Schmidt. 1996. Microbial activity under alpine snowpacks, Niwot Ridge, Colorado. *Biogeochemistry* 32:93-113.
- Bytnerowicz, A., R. F. Johnson, L. Zhang, G. D. Jenerette, M. E. Fenn, S. L. Schilling, and I. Gonzalez-Fernandez. 2015. An empirical inferential method of estimating nitrogen deposition

to Mediterranean-type ecosystems: The San Bernardino mountains case study. *Environmental Pollution* 203:69-88.

Clarke, N., D. Zlindra, E. Ulrich, R. Mosello, J. Derome, K. Derome, N. König, G. Lövblad, G. P. J. Draaijers, K. Hansen, A. Thimonier, and P. Waldner. 2016. Sampling and analysis of deposition. Part XIV. Page 66. Manual on methods and criteria for harmonized sampling, assessment, monitoring and analysis of the effects of air pollution on forests. UNECE, ICP Forests, Hamburg.

Clow, D. W., H. A. Roop, L. Nanus, M. E. Fenn, and G. A. Sexstone. 2015. Spatial patterns of atmospheric deposition of nitrogen and sulfur using ion-exchange resin collectors in Rocky Mountain National Park, USA. *Atmospheric Environment* 101:149-157.

Cornell, S. 2011. Atmospheric nitrogen deposition: revisiting the question of the invisible organic fraction. *Procedia Environmental Sciences* 6:96-103.

Devlaeminck, R., A. De Schrijver, and M. Hermy. 2005. Variation in throughfall deposition across a deciduous beech (*Fagus sylvatica* L.) forest edge in Flanders. *Science of the Total Environment* 337:241-252.

Draaijers, G. P. J., J. W. Erisman, T. Spranger, and G. P. Wyers. 1996. The application of throughfall measurements for atmospheric deposition monitoring. *Atmospheric Environment* 30:3349-3361.

Elliott, E. M., C. Kendall, E. B. Boyer, D. A. Burns, G. Lear, H. E. Golden, K. Harlin, A. Bytnerowicz, T. J. Butler, and R. Glatz. 2009. Dual nitrate isotopes in dry deposition: Utility for partitioning NO_x source contributions to landscape nitrogen deposition. *Journal of Geophysical Research: Biogeosciences* 114:G04020.

Fenn, M. E. and M. A. Poth. 2004. Monitoring nitrogen deposition in throughfall using ion exchange resin columns: A field test in the San Bernardino Mountains. *Journal of Environmental Quality* 33:2007-2014.

Fenn, M. E., C. S. Ross, S. L. Schilling, W. D. Baccus, M. A. Larrabee, and R. A. Lofgren. 2013. Atmospheric deposition of nitrogen and sulfur and preferential canopy consumption of nitrate in forests of the Pacific Northwest, USA. *Forest Ecology and Management* 302:240-253.

Fenn, M.E., Bytnerowicz, A. and Schilling, S.L. 2018. Passive monitoring techniques for evaluating atmospheric ozone and nitrogen exposure and deposition to California ecosystems. Gen. Tech. Rep. PSW-GTR-257. Albany, CA: U.S. Department of Agriculture, Forest Service, Pacific Southwest Research Station. 129 p.

Guerrieri, R., Vangelova, E.I., Michalski, G., Heaton, T.H.E. and Mencuccini, M. 2015. Isotopic evidence for the occurrence of biological nitrification and nitrogen deposition processing in forest canopies. *Global Change Biology* 21: 4613-4626.

- Hansen, K., A. Thimonier, N. Clarke, J. Staelens, D. Žlindra, P. Waldner, and A. Marchetto. 2013. Atmospheric deposition to forest ecosystems. *in* M. Ferretti and R. Fischer, editors. *Developments in Environmental Science. Volume 12: Forest monitoring: methods for terrestrial investigations in Europe with an overview of North America and Asia.* Elsevier: Oxford, UK.
- Hastings, M. G., D. M. Sigman, and F. Lipschultz. 2003. Isotopic evidence for source changes of nitrate in rain at Bermuda. *J. Geophys. Res.* 108:4790.
- Heaton, T. H. E., B. Spiro, S. Madeline, and C. Robertson. 1997. Potential canopy influences on the isotopic composition of nitrogen and sulphur in atmospheric deposition. *Oecologia* 109:600-607.
- Houle, D., R. Ouimet, R. Paquin, and J.-G. Laflamme. 1999. Determination of sample size for estimating ion throughfall deposition under a mixed hardwood forest at the Lake Clair Watershed (Duchesnay, Quebec). *Canadian Journal of Forest Research* 29:1935-1943.
- Levia, D. F. and E. E. Frost. 2006. Variability of throughfall volume and solute inputs in wooded ecosystems. *Progress in Physical Geography* 30:605-632.
- Levia, D. F., R. F. Keim, D. E. Carlyle-Moses, and E. E. Frost. 2011. Throughfall and Stemflow in Wooded Ecosystems. Pages 425-443 *in* D. F. Levia, D. Carlyle-Moses, and T. Tanaka, editors. *Forest Hydrology and Biogeochemistry: Synthesis of Past Research and Future Directions.* Springer Netherlands, Dordrecht.
- Lovett, G. M. and S. E. Lindberg. 1993. Atmospheric deposition and canopy interactions of nitrogen in forests. *Canadian Journal of Forest Research* 23:1603-1616.
- Nanus, L., M. W. Williams, D. H. Campbell, E. M. Elliott, and C. Kendall. 2008. Evaluating Regional Patterns in Nitrate Sources to Watersheds in National Parks of the Rocky Mountains using Nitrate Isotopes. *Environmental Science & Technology* 42:6487-6493.
- Nordén, U. 1991. Acid deposition and throughfall fluxes of elements as related to tree species in deciduous forests of South Sweden. *Water, Air, and Soil Pollution* 60:209-230.
- Rao, L. and E. Allen. 2010. Combined effects of precipitation and nitrogen deposition on native and invasive winter annual production in California deserts. *Oecologia* 162:1035-1046.
- Rhodes, C., A. Bingham, A. M. Heard, J. Hewitt, J. Lynch, R. Waite, and M. D. Bell. 2017. Diatoms to human uses: linking nitrogen deposition, aquatic eutrophication, and ecosystem services. *Ecosphere* 8:e01858.
- Robertson, S. M. C., M. Hornung, and V. H. Kennedy. 2000. Water chemistry of throughfall and soil water under four tree species at Gisburn, northwest England, before and after felling. *Forest Ecology and Management* 129:101-117.

Schwede, D. B. and G. G. Lear. 2014. A novel hybrid approach for estimating total deposition in the United States. *Atmospheric Environment* 92:207-220.

Sparks, J.P. 2009. Ecological Ramifications of the Direct Foliar Uptake of Nitrogen. *Oecologia* 159: 1-13.

Templer, P. H. and K. C. Weathers. 2011. Use of mixed ion exchange resin and the denitrifier method to determine isotopic values of nitrate in atmospheric deposition and canopy throughfall. *Atmospheric Environment* 45:2017-2020.

Templer, P. H., K. C. Weathers, H. A. Ewing, T. E. Dawson, S. Mambelli, A. M. Lindsey, J. Webb, V. K. Boukili, and M. K. Firestone. 2015. Fog as a source of nitrogen for redwood trees: evidence from fluxes and stable isotopes. *Journal of Ecology* 103:1397-1407.

Van Stan li, J. T. and T. G. Pypker. 2015. A review and evaluation of forest canopy epiphyte roles in the partitioning and chemical alteration of precipitation. *Science of the Total Environment* 536:813-824.

Watanabe, K., A. Kohzu, W. Suda, S. Yamamura, T. Takamatsu, A. Takenaka, M. K. Koshikawa, S. Hayashi, and M. Watanabe. 2016. Microbial nitrification in throughfall of a Japanese cedar associated with archaea from the tree canopy. *SpringerPlus* 5:1596.

Williams, J. J., S. H. Chung, A. M. Johansen, B. K. Lamb, J. K. Vaughan, and M. Beutel. 2017. Evaluation of atmospheric nitrogen deposition model performance in the context of U.S. critical load assessments. *Atmospheric Environment* 150:244-255.

Wilson, B. T., A. J. Lister, and R. I. Riemann. 2012. A nearest-neighbor imputation approach to mapping tree species over large areas using forest inventory plots and moderate resolution raster data. *Forest Ecology and Management* 271:182-198.

3.1.1.4. Total atmospheric Nr deposition in urban areas

Gregory A. Wetherbee¹, Pamela H. Templer², Richard V. Pouyat³, Stephen M. Decina⁴, Brian M. Kerschner⁵, Thomas H. Whitlow⁶, Pamela E. Padgett⁷

¹U.S. Geological Survey, Denver, CO

²Boston University, Boston, MA

³U.S. Forest Service, Bethesda, MD

⁴University of California, Berkeley, CA

⁵Prairie Research Institute, Illinois State Water Survey, Champaign, IL

⁶Cornell University, Ithaca, NY

⁷U.S. Forest Service, Riverside, CA

Research topic summary

Accurate estimates of wet and dry deposition of reactive nitrogen (Nr) species in urban areas are needed to evaluate total inputs of Nr to terrestrial and aquatic ecosystems and to understand their sources. The necessity of understanding deposition to urban areas is becoming more evident as recent studies indicate differences in the amount (Bettez and Groffman, 2013, Padgett, 1999; Bytnerowicz et al. 2015), speciation (Du et al., 2014; Lloret et al., 2016; Li et al., 2016; Decina et al., 2017; Fenn et al., 2018), and seasonal patterns of deposition between urban and rural environments (Zbieranowski and Aherne, 2012). Due to a paucity of monitoring data, Nr deposition in urban environments is not well characterized.

New measured and modeled data are needed to characterize atmospheric Nr deposition in urban landscapes, which are inherently complex due to the presence of built structures, heterogeneous local emission sources, and changing Nr speciation. This complexity creates logistical challenges for sampling strategies to characterize the large degree of spatial and temporal variability of deposition within the urban area and represents the most substantial knowledge gap in the field. Three main strategies exist to address this gap.

The first strategy is sampling outside the influence of urban emission sources with little or no prior knowledge of their radii of influence. This has been attempted by sampling upwind and downwind of the urban area, far enough from local sources to allow for adequate mixing and characterization of a net urban signal (Lovett et al., 2000; Cook et al., 2018). Challenges of this kind of monitoring include site characteristics such as appropriate fetch, power, protection of instrumentation, and selection of appropriate distances from emission sources.

The second strategy is sampling en masse within the urban environment (Marr et al., 2013) to statistically characterize variability. This strategy is most cost-effective using passive samplers

and adapting methods for optimal urban deployment, such as ion exchange resin (IER) collectors (Decina et al., 2018). Passive techniques commonly provide lower temporal resolution such as bi-weekly, monthly, quarterly, or seasonal deposition data, and representativeness is evaluated and calibrated with independent methods (Fenn and Poth, 2004, Simkin et al., 2004).

A third strategy is advancement of atmospheric deposition modeling with parameters appropriate for urban environments, such as deposition velocities, bi-directional flux, and speciation over urban-rural gradients (Schrader and Brümmer, 2014; Bash et al., 2013; Pleim et al., 2013; Zhang et al., 2003). In the near-term, this knowledge gap could be addressed by standardizing and compiling air-quality monitoring data currently being collected through national urban monitoring networks, conducting studies to develop protocols for site selection in urban areas, and expanding low-cost monitoring in urban areas using passive methods for air concentrations and bulk/throughfall deposition (Cook et al., 2018). Intra-urban environment modeling studies could be focused on characterizing subcategories of urban land-use types, and/or assessing the importance of parameters such as population density, tree cover, asphalt cover, building height, transportation, and the changing importance of reduced versus oxidized Nr species and organic Nr (Fenn et al., 2018; Decina et al., 2018, Sun et al., 2017). Longer-term efforts include expansion of the National Atmospheric Deposition Program National Trends Network (NADP NTN) to include more urban locations and intensive studies using detailed measurements to characterize deposition processes and Nr speciation in urban landscapes. Expanded monitoring and intensive studies can improve models for simulating atmospheric deposition in urban environments.

Introduction

The importance of measuring and understanding total nitrogen deposition in cities cannot be overstated. Over 50 percent of the world's population lives in urban areas with an expected increase to 66% by 2050 (United Nations, 2015). Population centers are dynamic, with emissions from stationary, mobile, and transient air-pollution sources due to a concentration of human activities, the most important being automobiles (Mage et al., 1996; Mayer, 1999). These urban sources also affect the chemical makeup and physical deposition characteristics of airborne materials (Bettez et al., 2013; Hamilton et al., 1995; Hofman et al., 2014; Jin et al., 2014; Kirchner et al., 2005; Lovett et al., 2000; Templer and McCann 2010; Rao et al. 2014). Estimation of both dry and wet deposition of chemical constituents is complicated by the spatial and temporal variability of the many types of emission sources and deposition surfaces in urban areas (Decina et al., 2017; Cook et al., 2018).

Selection of monitoring locations must consider the complexity of urban landscape surfaces, such as trees, buildings, overhead wires, roads, waterways, pedestrian and vehicle traffic, and other unique structures that can interfere with representative environmental air and precipitation sampling (NADP, 2014). Urban monitoring is sometimes located on rooftops to

protect instruments and samples from vandalism and theft, but the potential difference in deposition between roof and ground surfaces is not well characterized. All of these elements present challenges to collection of atmospheric deposition data that are representative of chemical concentrations in urban air and precipitation.

Regulatory air-quality monitoring has produced a substantial quantity of data for estimation of atmospheric dry deposition in urban areas (e.g., U.S. Environmental Protection Agency (USEPA) Chemical Speciation Network (CSN), (<https://www3.epa.gov/ttnamti1/speciepg.html>) (Figure 1). Additionally, speciated air-quality monitoring is also occurring in National Parks where Interagency Monitoring of Protected Visual Environments (IMPROVE) network data are collected for protection of scenic vistas and sensitive ecosystems (e.g., <http://vista.cira.colostate.edu/Improve/improve-program/>). The Clean Air Status and Trends Network (CASTNET) fills in many of the ambient air-quality data gaps in regionally representative areas (https://java.epa.gov/castnet/epa_ isp/sites.jsp).

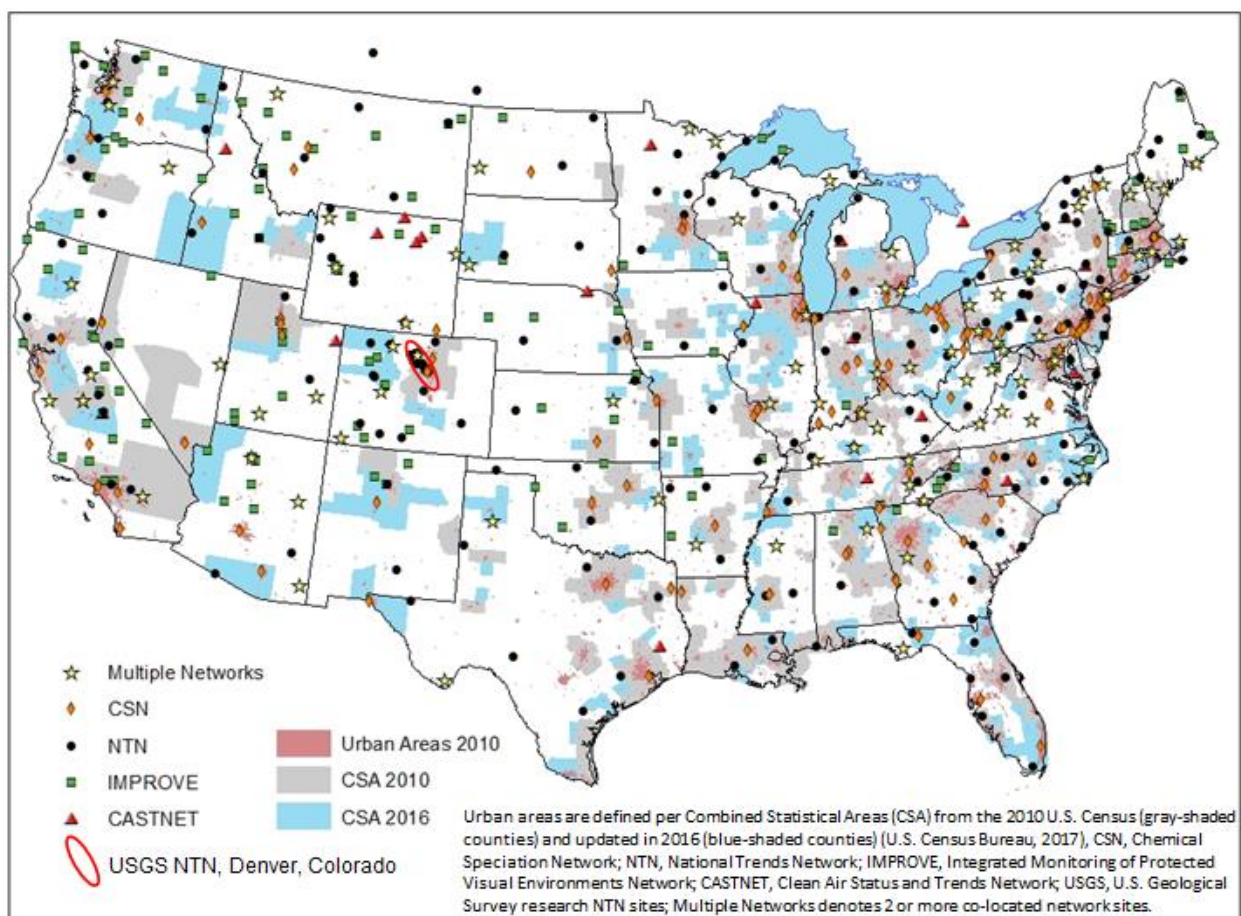

Figure 1. Urban areas, projected population growth areas (CSAs), and locations of ambient air and atmospheric deposition monitoring network sites in the contiguous 48 United States.

There is a paucity of wet and dry deposition data for urban environments in the USA. The CASTNET monitors Nr species in regionally representative areas external to urban emission

influences. Dry deposition of Nr can be estimated from urban ambient air-quality monitoring data obtained by the CSN. However, assumptions of deposition velocities and bi-directional fluxes, which vary with land surface cover, are needed to estimate dry Nr deposition from CASTNET and CSN measurements.

Wet deposition monitoring by the NADP purposely avoids urban areas in favor of collecting regionally representative data, which underestimates the potential effect of Nr deposition on surface waters (Howarth 2007). Currently, only 7% (19 of the 261) NADP/NTN sites are classified as “urban” where “urban” is defined as a site within 15 km of an area where population density exceeds 400 people km⁻². The historical focus of the NADP/NTN on rural sites allowed for representative measurements from rural and isolated areas to be extrapolated across the entire U.S. landscape. However, this extrapolation included interpolation of nitrogen deposition to urban areas without regard to any urban-rural gradients in emissions and associated wet deposition. Therefore, NADP annual wet deposition maps underestimate rates of deposition in urban areas (Howarth, 2007; Redling et al. 2013; Elliott et al. 2007; Rao et al. 2014).

Clearly, the first step toward better understanding of urban wet and dry deposition across the U.S. is to increase the number of NADP sites in major metropolitan areas (Rao et al., 2014). The challenge is finding suitable locations where monitoring data will appropriately represent the variability of wet deposition in the complex urban environment (Decina et al., 2018). In addition to, or in lieu of, operating multiple monitoring stations within each urban area, studies are needed to arrive at algorithms to estimate the spatial and temporal variability of urban deposition across different types of urban-rural gradients. Evaluation of the radii of urban influence and extents of urban-rural gradients in Nr wet deposition across multiple regions of the U.S. is needed to better understand atmospheric deposition to urban ecosystems.

A consequence of preferred location selection for both NTN and CASTNET sites is that existing networks are strongly influenced by inputs from power plants because elevated smokestacks facilitate the regional transport of emissions (Elliott et al., 2007; Elliott et al., 2009). Despite the effectiveness of existing network sites at monitoring emission reductions stemming from the Clean Air Act and Amendments, there is growing concern that existing network site preferences overlook the single largest emission source in the U.S.-- vehicular emissions, which moreover are emitted closer to the ground and thus subject to local deposition (Elliott et al., 2007; Elliott et al., 2009; Redling et al., 2013, Fenn et al., 2018). Vehicular emissions are an important factor affecting changes in Nr speciation whereby reduced species are becoming more abundant relative to oxidized forms.

State of the science

Rural–Urban Transect Studies

Several transect studies document urban-rural gradients of atmospheric wet deposition of the major ion constituents monitored by NADP: calcium (Ca^{+2}), magnesium (Mg^{+2}), sodium (Na^+), potassium (K^+), ammonium (NH_4^+), chloride (Cl^-), bromide (Br^-), nitrate (NO_3^-), sulfate (SO_4^{-2}), and hydrogen-ion from pH (H^+). North American urban-rural transect studies include: Los Angeles, California (Bytnerowicz et al., 2015; Padgett et al., 1999), New York City (Lovett et al., 2000), Boston, Massachusetts (Decina et al., 2018, 2017; Rao et al., 2014; Templer and McCann 2010), Baltimore County, Maryland (Bettez and Groffman, 2013), Phoenix, Arizona (Cook et al., 2018; Lohse et al., 2008), Salt Lake City, Utah (Hall et al., 2014), and southern Ontario (Zbieranowski and Aherne, 2012). This list excludes several previous studies focused on Nr and many other studies on trace metals, including mercury, and volatile organic compounds. Much more work has been done in China (Sun et al., 2017; Wang et al., 2016; Huang et al., 2015; Li et al., 2013; Pan et al., 2012).

Transect studies indicate pronounced urban-rural gradients in deposition. For example, deposition in Baltimore County measured 47 percent higher in urban and 22 percent higher in suburban compared to rural areas (Bettez and Groffman, 2013). In southern Ontario, Zbieranowski and Aherne (2012) observed greater fluxes (calculated from concentrations) and spatial variability of ammonia (NH_3), nitrous oxide (NO_2), and nitric acid (HNO_3) concentrations in ambient air samples from urban and agricultural areas compared to a rural site. They also noted that seasonal variation of the concentrations of these species was different between agricultural and urban sites. During winter, concentrations of NH_3 decreased by 35 percent in Toronto, 52-58 percent in agricultural areas, and 90 percent at a rural site as compared to non-winter concentrations. This indicates additional NH_3 emission sources in urban environments that are evident even during winter months.

The seasonality of urban Nr deposition is evident in surface materials. Padgett et al. (1999) sampled ambient air, soil, and soil leachate in an urban-suburban-rural transect in the Santa Ana Mountains between Los Angeles and San Diego, California. They observed similar patterns in air, soil, and leachate NO_3^- and NH_4^+ variability, both seasonally and spatially. Summer atmospheric concentrations of NO_3^- varied more than three-fold along the gradient, but the NH_4^+ concentration gradient was less steep. Monitoring sites closer to Los Angeles exhibited annual Nr concentrations in air and soil that were consistently higher than for the more rural sites regardless of season.

In a transect along the San Bernardino Mountains of southern California, Bytnerowicz et al. (2015) obtained concentrations of Nr species in air and wet throughfall samples. They showed that total Nr deposition along the San Bernadino Mountains ranged from greater than 60 to less than 3 $\text{kg ha}^{-1} \text{ yr}^{-1}$ (urban to rural, respectively). They noted that although average Nr deposition (9.8-12.0 $\text{kg N ha}^{-1} \text{ yr}^{-1}$) was consistent with regional estimates by Community Multiscale Air Quality Model (CMAQ) and Total Deposition Model (TDep) (<http://www.epa.gov/AMD/Research/RIA/cmaq.html>; Schwede and Lear, 2014), the Nr

deposition in this region was grossly underestimated by TDep in the western region near urban Los Angeles.

Rao et al. (2014) characterized urban-rural Nr deposition and its effects in Boston using IER throughfall collectors, resin bag soil leachate collectors, and soil samples. They observed more than 100% greater annual Nr deposition at urban compared to non-urban sites, with NH_4^+ -N contributing three times more mass than NO_3^- -N. They also found that Nr inputs along urbanization gradients correlated with proximity to the urban core and traffic intensity measured through on-road CO_2 emissions. Recent research throughout the Boston Metropolitan Area demonstrates that atmospheric deposition in urban areas is both elevated and highly spatially variable relative to nearby rural ecosystems (Decina et al., 2017). For example, the range of deposition values observed by Decina et al. (2017) in the urban Boston area spans the entire deposition flux range observed between Boston's city center and a rural forest 65 miles away (Rao et al. 2014). These results indicate that multiple monitoring stations are required within urban areas to accurately characterize the variability of emissions and deposition in these ecosystems and in urban-rural gradients.

Urbanization and Nr gradients do not always behave in parallel. For example, an urban-montane transect near Salt Lake City was monitored using bulk and surface snow samples. Deposition in snow in the Wasatch Mountains east of Salt Lake City was observed in a specific altitudinal band (i.e. "bathtub ring") due to cool air pooling in winter (Hall et al., 2014), indicating that terrain complexity, as well as distance from the urban core, were important to measuring deposition. On the other hand, an urban-rural transect in Phoenix indicated no significant relation between wet deposition and distance from the urban core using Aerochem wet-dry collectors (Lohse et al., 2008). Rather, spatial variation in Phoenix wet-dry deposition was more related to seasonal storm characteristics, and dry deposition outranked wet deposition in importance for NH_4^+ . Dust also supplied condensation nuclei that enhanced wet deposition downwind of the Phoenix urban core (Lohse et al., 2008).

More recent work in Phoenix by Cook et al. (2018) confirmed the importance of NH_4^+ especially during summer, and they also found that dry deposition was significantly underestimated from throughfall. Accounting for dry deposition from multiple sampling techniques, Cook et al. found that overall deposition rates were relatively low for a large city, but total deposition was higher in the city and at or above the Nr deposition critical load.

Particulate Monitoring

Particulate monitoring across urban areas is the backbone of air-quality monitoring (USEPA, 2015). Dust is a major component of urban air pollution, and it influences urban deposition in several ways, including neutralization of acidity (Lovett et al., 2000) and influencing active transport of particulate-associated Nr (Hall et al., 2014; Hamilton et al., 1995; Hedin and Likens, 1996; 2014; Lohse et al., 2008; Samara and Tsitouridou, 2000; Tsitouridou et al., 2003; Wolfe, 1984). There is evidence that the world is becoming dustier (Psenner, 1999), and such trends

could alter urban deposition patterns, as indicated in Phoenix. Meanwhile parts of the U.S. are less dusty than in the past due to paving, resulting in reduced cation deposition rates (Hedin et al., 1994; Seinfeld, 1989).

In addition to being a source of dust, transportation is the single largest and most overlooked source of Nr emissions to the atmosphere, accounting for over half of the total NO_x emissions in the eastern USA (Butler et al., 2005; Bettez et al., 2013; Redling et al., 2013). Catalytic converters in vehicle exhaust trains are a large source of NH₃, deposited primarily as NH₄⁺ along roads (Bettez et al., 2013, Kirchner et al., 2005, Cape et al., 2004), whereas other urban NH₃ sources include volatilization of fertilizers and sewer gas (Felix et al., 2014). Deposition of Nr within 10 m of roads on Cape Cod, Massachusetts, was more than double that in areas away from roads, and most elevated deposition occurred within 50–100 m from roads (Bettez et al., 2013). In a study in Scotland, gas concentrations fell 90% within 10 m from a road for NH₃ and within 15 m for NO₂ (Cape et al., 2004). Concentrations above background, estimated at the edge of the traffic lane, were linearly proportional to traffic density for NH₃. In a 400-m transect spanning a moderately trafficked interstate in Pennsylvania, Redling et al. (2013) documented near-road NO₂ fluxes that were four times larger than regional background deposition. Modeled extrapolation of near-road fluxes indicated that 45% of roads in urban Philadelphia have Nr fluxes higher than regional backgrounds (measured at CASTNET sites) and that these urban, near-road fluxes are up to 14 times higher than regional background (Redling et al., 2013). The Cape Cod, Baltimore County, and Pennsylvania studies point out that near-source deposition along roads is not measured by current wet- and dry deposition networks (Bettez et al., 2013; Redling et al., 2013), yet near-road deposition can be an important nutrient source for near-road vegetation and stormwater runoff (Redling et al., 2013; Divers et al., 2014).

Occult Deposition

Another component of deposition missed by most networks is fog (a.k.a “occult deposition”). Fenn et al. (2000) estimated that fog deposition contributed 13-35 percent of the total annual Nr deposition at two forested sites in the San Bernardino Mountains east of Los Angeles. Nr in fog water makes up approximately one-third of annual atmospheric Nr inputs to coastal redwood ecosystems in California (Ewing et al., 2009). Substantial concentrations of dissolved organic and inorganic Nr were also found in fog waters in Davis, California (Zhang and Anastasio, 2001). Deposition of Nr in fog could be especially important in urban environments, where trees and tall buildings can act as surfaces for condensation of fog droplets.

Effects of Urban Deposition Attenuation

Much research has been done on atmospheric deposition to urban forests (Decina et al., 2018; Bai et al., 2015, deSouza et al., 2015; Gregg et al., 2003, Lovett et al., 2000, Pouyat et al., 2008; Pouyat et al., 1995) and to structures such as buildings, monuments, and statues (Dolske, 1995; Hamilton et al., 1995). These studies focus on the effects of deposition on forests and

structures, not on how these components of the urban environment directly affect the estimation of total Nr deposition to the landscape. Therein lies an important question about the meaning of total urban atmospheric deposition; whether total Nr deposition should account for dynamic re-emission or biological attenuation of the initial deposition incident on urban surfaces, or whether taking these processes into account actually underestimates total deposition.

Future research

The challenges that lie ahead for understanding atmospheric deposition in urban areas are many. The following list of research needs is ordered by a combination of relative importance and relation between costs and benefits. This is not intended to be an exhaustive list; more questions about urban deposition will assuredly arise as more is learned.

1. Expand wet and dry deposition networks (e.g. NADP/NTN, CASTNET, IMPROVE, CSN) in urban areas to characterize variability in urban wet deposition. Include at least one comparative study of deposition fluxes measured at co-located (or nearby) ground- and roof-based NTN sites within each urban ecosystem.
2. Compile air-quality monitoring records for Nr species in urban air into a standardized database for common research use (e.g., EPA CSN, IMPROVE, CASTNET).
3. Investigate the relation between atmospheric deposition and human population growth in different precipitation regimes and ecosystem types using existing monitoring data, geographic information systems, and new studies with urban-rural transect monitoring involving roads, trees, soils, and throughfall.
4. Conduct wet and dry deposition studies aimed at proper selection of monitoring locations with respect to urban emission sources (e.g., transportation versus fixed energy production, waste treatment, and disposal); meteorology (e.g., heat islands, building canyons); and vegetation and other landscape characteristics (e.g., urban forests, waterways, parks, buildings).
5. Further develop monitoring techniques for passive NH₃, organic Nr, and oxidized Nr species for ambient air (e.g., NADP/AMoN, other research networks). Passive sampling can help add to our understanding of heterogeneity of the urban landscape.
6. Further develop and expand use of IER sampling of bulk Nr deposition and throughfall in urban transects to: (a) calibrate IER measurements to more sensitive and discrete deposition measurements, and (b) better define spatial and temporal variability of urban Nr deposition. The use of IER column collectors is a relatively inexpensive and effective way to measure

deposition at multiple locations because they can be left in the field for several weeks, while the chemistry of samples is preserved (Simkin et al., 2004).

7. Conduct modeling studies to develop algorithms for urban deposition based on emission source terms and landscape characteristics and dynamics. Targeted modeling efforts informed by isotopic approaches/investigations could identify whether the Nr deposited in urban areas is locally emitted, or whether there is substantial regional transport to or away from urban areas. Incorporation of data-verified algorithms for roadside deposition based on traffic density and other parameters into these targeted modeling studies is needed.

8. Conduct studies of Nr in urban fog (occult deposition) and develop estimates of its relative importance to total deposition.

9. Evaluate how structures (e.g., buildings) and urban forests affect estimation of total deposition variability in the urban environment.

10. Improve modeling techniques to better define the radius of influence of urban emissions on surrounding areas. In addition, characterize long-term and changing deposition patterns in cities related to changing global and local climates.

References

Bai, S.H., Xu, Z., Blumfield, T.J., and Reverchon, F., 2015, Human footprints in urban forests: implication of nitrogen deposition for nitrogen and carbon storage, *J Soils Sediments* 15: 1927–1936, DOI: 10.1007/s11368-015-1205-4.

Bash, J.O., Cooter, E.J., Dennis, R.L., Walker, J.T., and Pleim, J.E., 2013, Evaluation of a regional air-quality model with bidirectional NH₃ exchange coupled to an agroecosystem model, *Biogeosciences* 10: 1635–1645.

Bettez, N.D. and Groffman, P.M., 2013, Nitrogen deposition in and near an urban ecosystem, *Environ. Sci. Technol.* 2013, 47: 6047–6051, DOI: 10.1021/es400664b.

Bettez, N.D., Marino, R., Howarth, R.W., and Davidson, E.A., 2013, Roads as nitrogen deposition hot spots, *Biogeochem.* 114: 149–163, DOI: 10.1007/s10533-013-9847-z.

Butler, T.J., Likens, G.E., Vermeylen, F.M., and Stunder, B.J.B., 2005, The impact of changing nitrogen oxide emissions on wet and dry nitrogen deposition in the northeastern USA, *Atmos. Environ.* 39: 4851–4862.

Bytnerowicz, A., Johnson, R.F. Zhang, L., Jenerette, G.D., Fenn, M.E., Schilling, S.L., and Gonzalez-Fernandez, I., 2015, An empirical inferential method of estimating nitrogen deposition

to Mediterranean-type ecosystems: the San Bernardino Mountains case study, *Environ. Pollut.* 203: 69-88.

Cape, J.N., Tang, Y.S., van Dijk, N., Love, L., Sutton, M.A., and Palmer, S.C.F., 2004, Concentrations of ammonia and nitrogen dioxide at roadside verges, and their contribution to nitrogen deposition, *Environ. Pollut.* 132: 469–478.

Cook, E.M., Sponseller, R., Grimm, N.B., and Hall, S.J., 2018, Mixed method approach to assess atmospheric nitrogen deposition in arid and semi-arid ecosystems, *Environ. Pollut.* 239: 617–630.

Decina, S.M., Templer, P.H., Hutyra, L.R., Gately, C.K., and Rao, P., 2017, Variability, drivers and effects of atmospheric nitrogen inputs across an urban area; Emerging patterns among human activities, the atmosphere and soils, *The Sci. Tot. Environ.* 609: 1524-1534, DOI: 10.1016/j.scitotenv.2017.07.166.

Decina, S.M., Templer, P.H., and Hutyra, L.R., 2018, Atmospheric inputs of nitrogen, carbon, and phosphorus across an urban area: Unaccounted fluxes and canopy influences, *Earth's Future* 6: 134–148, DOI: 10.1002/2017EF000653.

de Souza, P.A., Ponette-González, A.G., de Mello, W.Z., Weathers, K.C., and Santos, I.A., 2015, Atmospheric organic and inorganic nitrogen inputs to coastal urban and montane Atlantic Forest sites in southeastern Brazil, *Atmos. Res.* 160: 126–137.

Divers, M.T., Elliot, E.M., and Bain, D.J., 2014, Quantification of nitrate sources to an urban stream using dual nitrate isotopes, *Environ. Sci. Technol.* 48: 10580–10587, DOI: 10.1021/es404880j.

Dolske, D.A., 1995, Deposition of atmospheric pollutants to monuments, statues, and buildings, *The Sci. Tot. Environ.* 167: 15–31.

Du, E., DeVries, W., Galloway, J.N., Hu, X., and Fang, J., 2014, Changes in wet nitrogen deposition in the United States between 1985 and 2012, *Environ. Res. Lett.* 9, 8 p., DOI: 10.1088/1748-9326/9/9/095004

Elliot, E.M., Kendall, C., Boyer, E.W., Burns, D.A., Lear, G.G., Golden, H.E., Halin, K., Bytnerowicz, A., Butler, T.J., and Glatz, R., 2009, Dual nitrate isotopes in dry deposition: Utility for partitioning NO_x source contributions to landscape nitrogen deposition, *J. Geophys. Res.* 114: 15 p.

Elliott, E.M., Kendall, C., Wankel, S.D., Burns, D.A., Boyer, E.W., Harlin, K., Bain, D.J., and Butler, T.J., 2007, Nitrogen isotopes as indicators of NO_x source contributions to atmospheric nitrate deposition across the Midwestern and Northeastern United States, *Environ. Sci. Technol.* 41 (22): 7661–7667, DOI: 10.1021/es070898t.

Ewing H.A., Weathers, K.C., Templer, P.H., Dawson, T.E., Firestone, M.K., Elliott, A.M., and Boukili, V.K.S., 2009, Fog water and ecosystem function: heterogeneity in a California redwood forest. *Ecosystems* 12: 417-433.

Felix, J.D., Elliot, E.M., Gish, T., Maghirang, R., Cambal, L., and Clougherty, J., 2014, Examining the transport of ammonia emissions across landscapes using nitrogen isotope ratios, *Atmos. Environ.* 95: 563-570.

Fenn, M.E. and Poth, M.A., 2004, Atmospheric pollutants and trace gases, monitoring nitrogen deposition in throughfall using ion exchange resin columns: A field test in the San Bernardino Mountains, *J. Environ. Qual.* 33: 2007–2014.

Fenn M.E., Bytnerowicz, A., Schilling, S.L., Vallanob, D.M., Zavaleta, E.S., Weiss, S.B., Morozumi, C., Geiser, L.H., and Hanks, K., 2018, On-road emissions of ammonia: An underappreciated source of atmospheric nitrogen deposition, *Sci. Total Environ.* 625: 909–919.

Fenn, M.E., Poth, M.A., Schilling, S.L., and Grainger, D.B., 2000, Throughfall and fog deposition of nitrogen and sulfur at an N-limited and N-saturated site in the San Bernardino Mountains, southern California, *Can. J. For. Res.* 30: 1476–1488.

Gregg, J.W., Jones, C.G., and Dawson, T.E., 2003, Urbanization effects on tree growth in the vicinity of New York City, *Nature* 424 (July 10, 2003): 183–187.

Hall, S.J., Maurer, G., Hoch, S.W., Taylor, R., and Bowling, D.R., 2014, Impacts of anthropogenic emissions and cold air pools on urban to montane gradients of snowpack ion concentrations in the Wasatch Mountains, Utah, *Atmos. Environ.* 98: 231–241.

Hamilton, R.S., Revitt, D.M., Vincent, K.J., and Butlin, R.N., 1995, Sulphur and nitrogen particulate pollutant deposition on to building surfaces, *The Sci. Tot. Environ.* 167: 57–66.

Hedin L.O., Granat, L., Likens, G.E., Buishand, T.A., Galloway, J.N., Butler, T.J., and Rodhe, H., 1994, Steep declines in atmospheric base cations in regions of Europe and North America, *Nature* 367: 351–4.

Hedin, L.O., and Likens, G.E., 1996, Atmospheric dust and acid rain, *Scientific American* (December 1996): 88–92.

Hofman, J., Bartholomeus, H., Calders, K., Van Wittenberghe, S., Wuyts, K., and Samson, R. 2014, On the relation between tree crown morphology and particulate matter deposition on urban tree leaves: A ground-based LiDAR approach, *Atmos. Environ.* 99: 130–139.

Howarth, R.W., 2007, Atmospheric deposition and nitrogen pollution in coastal marine ecosystems, *Acid in the Environment*, Springer U.S., pp. 97–116.

- Huang, J., Zhang, W., Zhu, X., Gilliam, F.S., Chen, H., Lu, X., and Mo, J., 2015, Urbanization in China changes the composition and main sources of wet inorganic nitrogen deposition, *Environ. Sci. Pollut. Res.* 22: 6526–6534, DOI 10.1007/s11356-014-3786-7.
- Jin, S., Guo, J., Wheeler, S., and Shengquan Che, L.K., 2014, Evaluation of impacts of trees on PM_{2.5} dispersion in urban streets, *Atmos. Environ.* 99: 277–287.
- Kirchner, M., Jakobia, G., Feichta, E., Bernhardt, M., and Fischer, A., 2005, Elevated NH₃ and NO₂ air concentrations and nitrogen deposition rates in the vicinity of a highway in southern Bavaria, *Atmos. Environ.* 39: 4531–4542.
- Li, K., Liu, X., Song, W., Chang, Y., Hu, Y., Tian, C., 2013, Atmospheric nitrogen deposition at two sites in an arid environment of Central Asia. *PLoS ONE* 8(6): e67018, DOI: 10.1371/journal.pone.0067018
- Li, Y., Schichtel, B.A., Walker, J.T., Schwede, D.B., Chen, X., Lehmann, C.M.B., Puchalski, M.A., Gay, D.A., and Collett Jr., J.L., 2016, Increasing importance of deposition of reduced nitrogen in the United States, *PNAS*, DOI: 10.1073/pnas.1525736113.
- Lloret, J., and Valiela, I., 2016, Unprecedented decrease in deposition of nitrogen oxides over North America: the relative effects of emission controls and prevailing air-mass trajectories, *Biogeochem.*, 129: 165-180, DOI 10.1007/s10533-016-0225-5.
- Lohse, K.A., Hope, D., Sponseller, R., Allen, J.O., and Grimm, N.B., 2008, Atmospheric deposition of carbon and nutrients across an arid metropolitan area, *Sci. Tot. Environ.* 402: 95-105.
- Lovett, G.M., Traynor, M.M., Pouyat, R.V., Carreiro, M.M., Zhu, W-X, and Baxter, J.W., 2000, Atmospheric deposition to oak forests along an urban-rural gradient, *Environ. Sci. Technol.* 34: 4294–4300.
- Mage, D., Ozonlins, G., Peterson, P., Webster, A., Orthofer, R., Vandeweerd, V., and Gwynne, M., 1996, Urban air pollution in megacities of the world, *Atmos. Environ.* 30(5): 681–686.
- Marr, L.C., Moore, T.O., Klapmeyer, M.E., Killar, M.B., 2013, Comparison of NO_x fluxes measured by eddy covariance to emission inventories and land use, *Environ. Sci. Technol.* 47: 1800–1808. [dx.doi.org/10.1021/es303150y](https://doi.org/10.1021/es303150y).
- Mayer, H., 1999, Air pollution in cities, *Atmos. Environ.* 33: 4029–4037.
- National Atmospheric Deposition Program (NADP), 2014, Site selection and installation manual, Ver. 1.9, https://nadp.slh.wisc.edu/lib/manuals/NADP_Site_Selection_and_Installation_Manual_2014_1.pdf, NADP Program Office, Wisconsin State Laboratory of Hygiene, Madison, WI., 18 p.

- Padgett, P.E., Allen, E.B., Bytnerowicz, A., and Minich, R.A., 1999, Changes in soil inorganic nitrogen as related to atmospheric nitrogenous pollutants in southern California, *Atmos. Environ.* 33: 769–781.
- Pan, Y.P., Wang, Y.S., Tang, G.Q., and Wa, D., Wet and dry deposition of atmospheric nitrogen at ten sites in Northern China, *Atmos. Chem. Phys.* 12: 6515–6535, DOI: 10.5194/acp-12-6515-2012.
- Pleim, J.E., Bash, J.O., Walker, J.T., and Cooter, E.J., 2013, Development and evaluation of an ammonia bidirectional flux parameterization for air quality models, *J. Geophys. Res.* 118: 3794–3806, DOI: 10.1002/jgrd.50262.
- Pouyat, R.V., McDonnell, M.J., and Pickett, S. T. A., 1995, Soil characteristics of oak stands along an urban-rural land-use gradient, *J. Environ. Qual.* 24: 516–526.
- Pouyat, R.V., Yesilonis, I.D., Szlavecz, K., Csuzdi, C., Hornung, E., Korso's, Z., Russell-Anelli, J., and Giorgio, V., 2008, Response of forest soil properties to urbanization gradients in three metropolitan areas, *Landscape Ecol.* 23: 1187–1203, DOI: 10.1007/s10980-008-9288-6.
- Psenner, R., 1999, Living in a dusty world: airborne dust as a key factor for alpine lakes, *Water Air Soil Pollut.* 112: 217–227.
- Rao, P., Hutyra, L. R., Raciti, S.M., and Templer, P.H., 2014, Atmospheric nitrogen inputs and losses along an urbanization gradient from Boston to Harvard Forest, MA, *Biogeochem.* 121: 229–245, DOI: 10.1007/s10533-013-9861-1.
- Redling, K., Elliot, E., Bain, D., and Sherwell, J., 2013, Highway contributions to reactive nitrogen deposition: tracing the fate of vehicular NO_x using stable isotopes and plant biomonitors, *Biogeochem.* 116: 261-274.
- Samara, C., and Tsitouridou, R., 2000, Fine and coarse ionic aerosol components in relation to wet and dry deposition, *Water Air Soil Pollut.* 120: 71–88.
- Schrader, F., and Brümmer, C., 2014, Land use specific ammonia deposition velocities: A review of recent studies (2004–2013), *Water Air Soil Pollut.* 225(10). DOI: 10.1007/s11270-014-2114-7.
- Schwede, D.B., Lear, G.G., 2014, A novel hybrid approach for estimating total deposition in the United States, *Atmos. Environ.* 92: 207–220.
- Seinfeld, J.H., 1989, Urban air pollution: State of the science, *Science* 243(4892): 745.
- Simkin, S.M., Lewis, D.N., Weathers, K.C., Lovett, G.M., and Schwarz, K., 2004, Determination of sulfate, nitrate and chloride in throughfall using ion-exchange resins. *Water Air Soil Pollut.* 153: 343–354.
- Sun, K., Tao, L., Miller, D.J., Pan, D., Golston, L.M., Zondlo, M.A., Griffin, R.J., Wallace, H.W., Jun, Y.J., Leong, Yang, M.M., Zhang, Y., Mauzerall, D.L., and Zhu, T., 2017, Vehicle emissions as an

important urban ammonia source in the United States and China, *Environ. Sci. Technol.* 51: 2472–2481, DOI: 10.1021/acs.est.6b02805.

Templer P.H., and McCann, T.M., 2010, Effects of the hemlock woolly adelgid on nitrogen losses from urban and rural northern forest ecosystems, *Ecosystems* 13: 1215–1226.

Tsitouridou, R., Voutsas, D., and Kouimtzis, Th., 2003, Ionic composition of PM₁₀ in the area of Thessaloniki, Greece, *Chemosphere* 52: 883–891.

United Nations, 2015, World urbanization prospects, The 2014 Revision, ST/ESA/SER.A/366, New York, p. xxi.

United States Census Bureau, 2017, TIGER/Line Shapefiles (machine-readable data files) prepared by the U.S. Census Bureau, 2017, accessed at: <https://www.census.gov/geo/maps-data/data/tiger-line.html>, May 9, 2017.

U.S. Environmental Protection Agency, 2015, 2013 National Monitoring Programs Annual Report (UATMP, NATTS, CSATAM), October 2015 Final Report, <https://www3.epa.gov/ttnamti1/files/ambient/airtox/2013nmpreport.pdf>.

Wang, H., Yang, R., Shi, G., Tian, M., Zhang, L., Zhang, L., and Fu, C., 2016, Ambient concentration and dry deposition of major inorganic nitrogen species at two urban sites in Sichuan Basin, China, *Environ. Pollut.* 219: 235–244.

Wolfe, G.T., 1984, On the nature of nitrate in coarse continental aerosols, *Atmos. Environ.* 18(5): 977–981.

Zbieranowski, A.L., and Aherne, J., 2012, Ambient concentrations of atmospheric ammonia, nitrogen dioxide and nitric acid across a rural –urban-agricultural transect in southern Ontario, Canada, *Atmos. Environ.* 62: 481–491.

Zhang, L., Brook, J.R., and Vet, R., 2003, A revised parameterization for gaseous dry deposition in air-quality models, *Atmos. Chem. and Phys.* 3(6): 2067–2082.

Zhang, Q., and Anastasio, C., 2001, Chemistry of fog waters in California's Central Valley—Part 3: concentrations and speciation of organic and inorganic nitrogen, *Atmos. Environ.* 35(32): 5629–5643.

3.1.1.5. Snow and atmospheric deposition

Gregory A. Wetherbee¹, Donna B. Schwede², Jill S. Baron³, David W. Clow¹, M. Alisa Mast¹, Graham A. Sexstone¹, Kristi H. Morris⁴

¹U.S. Geological Survey, Denver, CO

²U.S. EPA, Office of Research and Development, Durham, NC

³U.S. Geological Survey, Fort Collins, CO

⁴National Park Service, Lakewood, CO

Research topic summary

Many processes affect the interaction of atmospheric reactive nitrogen (Nr) with snow-covered landscapes. Accounting for these processes is important for accurate total Nr deposition estimates, especially in sensitive, high-altitude ecosystems, where critical loads for environmental effects are typically low (1 to 5 kg N ha⁻¹; Pardo et al., 2011; Nanus et al., 2012). Improvements to existing measurement and data validation methods as well as new spatially intensive measurements are needed to understand the representativeness and accuracy of historical measurements. Detailed measurements are needed to better understand the importance of dry deposition, surface chemistry, and snowmelt processes and to improve models of deposition to snow-covered surfaces.

In the near term, improvements in monitoring technology and techniques to obtain more representative measurements of wet deposition as snow include: improvement of National Atmospheric Deposition Program (NADP) data validation, completeness criteria, and protocols for calculation of precipitation-weighted mean concentrations; use of weekly bulk snow samples collocated at NADP sites to be used in cases when NADP samples are missed due to equipment failure; use of wind-shielded wet-deposition collectors to improve catch efficiency and limit wind-blown secondary snow deposition; and use of independent precipitation gages not impacted by wind-redistributed snow to correct snow-deposition measurements.

Deployment of bulk measurement methods to characterize spatial variability and deposition processes could also be accomplished in the near term using existing technology. Approaches could include the: use of ion exchange resin (IER) columns that capture precipitation samples from throughfall/bulk deposition collectors to augment summer deposition measurements; weekly bulk snow accumulation concentrations; use of passive sampler methods to characterize spatial variability of air concentrations to inform dry deposition estimates; measurement of bulk snow surface minus NADP National Trends Network (NTN) weekly concentration differences to estimate dry deposition; and the use of snowmelt lysimeters to characterize the Nr content, transformations, and subsurface movement of the snowpack during melting. With respect to measurement methods, a longer-term goal would be the

implementation of consistent and standardized routine deposition measurement methods at alpine sites. This would include measurements complementary to existing NTN methods such as those described above.

The remoteness and difficult terrain characteristic of alpine ecosystems makes sampling and establishment of monitoring sites logistically challenging and costly. For this reason, another near-term goal would be for monitoring agencies to leverage resources and collaboratively support existing sites where the measurements described above could be deployed. Additionally, developing a standardized database of non-NADP measurements would be an important step in cataloging existing measurements that could guide the selection of sites for collaborative efforts.

New measurements are needed to better understand the importance of dry deposition, surface chemistry, and snowmelt processes and to improve models of deposition to snow-covered surfaces. The processes that influence atmospheric deposition to snow surfaces can range in their relative impacts on the total deposition budget. These impacts should be considered along with logistical and cost considerations. Additional resources allocated to research of processes that contribute the largest fractions to total Nr deposition are warranted.

For instance, spring season fluctuations of snow surface phase changes (from solid to liquid and back) have been observed to be of high consequence on deposition velocities (Valdez, 1987) but are difficult to measure. A near-term goal would be to prioritize deposition model uncertainties (e.g., wet scavenging, gas exchange, and particulate deposition) to guide needed measurements (considering impacts and available budgets). Given the difficulty and expense of process-level experiments, the measurements themselves would represent a longer-term goal focused broadly on direct flux measurements to quantify dry deposition and re-emission from the snow surface and coupled air-surface flux and snow measurements to quantify surface resistances to deposition and the roles of surface wetness and chemistry.

Introduction

Small increases in atmospheric deposition of Nr can lead to measurable biogeochemical changes in ecosystems, such as forest and soil biogeochemical characteristics and surface-water quality (Baron et al., 2000; Burns, 2004, Brooks and Williams, 1999; Lawrence et al., 2000). Alpine environments are located at high-altitude where snow covers the landscape for large portions of the year (Kuhn, 2001). Snow serves as a reservoir of water and Nr for alpine ecosystems and influences soil moisture and temperature, decomposition, Nr mineralization, plant function, and length of the growing season by the timing of snowmelt (Bowman citing others, 1992). Elevation gradients also have been shown to be important in Nr deposition and cycling in these ecosystems (Brooks and Williams, 1999; Lawrence et al., 2000).

For this review, processes for quantifying deposition in and to snow are separated into wet deposition and dry deposition, consisting of both gas and particulate phases. A conceptual

diagram of Nr deposition and transformation in snow is illustrated in Figure 1. Wet deposition includes snow-out of Nr, including in-cloud or below-cloud scavenging and deposition to the land surface as adsorbed, dissolved, or occluded Nr in snow. Once the snow has been deposited on the land surface, it can be redistributed by wind (Williams et al., 1998). During wind pumping and ventilation, the snow can react with gaseous Nr (Domine and Shepson, 2002). Particulate deposition of Nr onto the snowpack surface in the form of dust or other wind-blown debris (Kuhn, 2001, Clow et al., 2016), re-emission of Nr from snow-covered surfaces and photolysis of Nr compounds (Domine and Shepson, 2002) also are important processes.

The relative importance of each process is ecosystem-specific and highly dependent on the temporal and spatial dynamics of snow accumulation and melt (Fenn et al., 2009). Initial wet deposition of soluble Nr in snow, throughfall, and dry deposition of gaseous Nr to snow-covered surfaces are likely of greatest importance to estimating initial total Nr deposition. Subsequent processes physically redistribute and chemically alter the various Nr species in the snowpack. For more detailed descriptions of these processes, the reader is referred to Kuhn (2001) and Domine and Shepson (2002).

Different phases of Nr deposition to snow can be measured independently, such as wet-only and dry-only collectors (i.e. bucket covered during precipitation events), or together in bulk collectors (Clow et al., 2015) or composite snowpack samples at the end of snow season (Ingersoll et al., 2016). Processes affecting the chemistry of the snow within the aging snowpack are measured by independent studies, but not long-term monitoring networks. Suggested methods to account for these processes in monitoring and modeling work are provided herein.

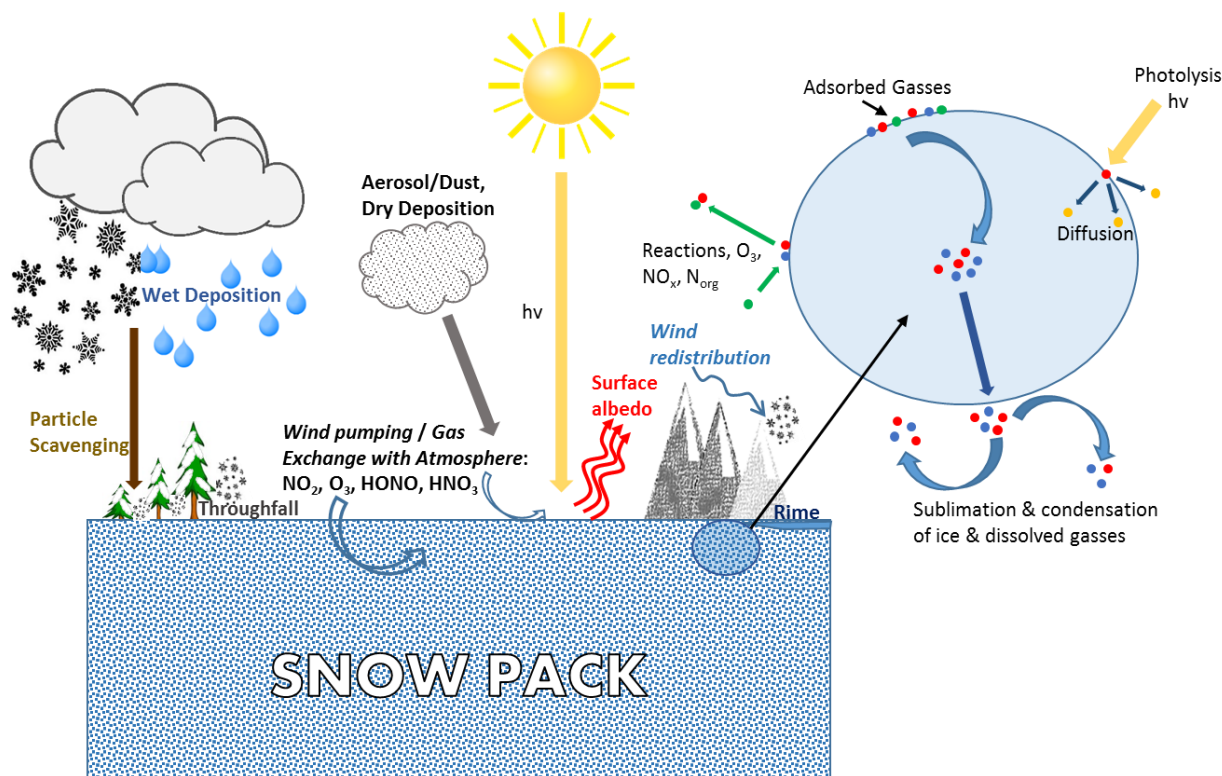

Figure 1. Conceptual diagram of processes for Nr deposition and transformation in snow (Modified from Domine and Shepson, 2002, Fig. 3).

Fenn et al. (2009) provide a thorough summary of the many methods for measurement of wet and dry deposition, including throughfall and branch-washing measurements. They report that bulk throughfall measurement, where the collector is continuously open to the sky, is considered an integrative technique that underestimates deposition during dry periods and overestimates wet-only deposition. Throughfall is what washes to the forest floor as a combination of wet, dry, and occult deposition. Therefore, it might be characterized as wet deposition plus some portion of dry deposition.

State of the science

Monitoring

Routine-deposition measurements of Nr in North American snow are available from a variety of monitoring networks such as NADP/NTN, the Canadian Air and Precipitation Monitoring Network (CAPMoN), and U.S. Geological Survey (USGS) snowpack chemistry network (https://co.water.usgs.gov/projects/RM_snowpack/index.html accessed May 19, 2017; Wetherbee et al., 2010; Ingersoll et al., 2016). The NADP wet-only deposition data include weekly wet-only concentrations, but because NADP samples are filtered upon laboratory receipt, any Nr from the particulate matter is largely excluded. The CAPMoN samples are not

filtered, and they are collected on an event-basis, which also allows for minimal degradation of Nr (Gilliland et al., 2002). The median CAPMoN-minus-NADP weekly concentration differences for samples collected at co-located sites during the 1995-2004 period were 0.062 mg/L for ammonium (NH_4^+) and 0.15 mg/L for nitrate (NO_3^-), compared to median CAPMoN concentrations of 0.387 mg/L and 1.932 mg/L, respectively (Sirois et al., 2000; Wetherbee et al., 2010). Therefore, the particulate Nr component is no more than 16 percent for NH_4^+ and 8 percent for NO_3^- , which is a small portion of total Nr deposition.

Snowpack data integrate both wet and dry deposition of NO_3^- and NH_4^+ , during the snow season. Clow et al. (2002) showed that annual snowpack chemical concentrations from the USGS snowpack chemistry network, collected at time of maximum accumulation, were very similar to NADP/NTN concentrations, except for calcium, which is an important component of dry-deposited dust. There is a paucity of data pertaining to how the snowpack affects dry deposition as the snowpack begins to melt and change as a reactive deposition surface throughout the melt season. Data for bulk deposition and snowpack measurements integrate not only dry deposition, but also fluxes from the snowpack to the atmosphere for chemicals with reactive gaseous phases. However, outfluxes are probably small for most species, including Nr.

Snow-season estimates of dry Nr deposition to snow can be made using ambient Nr concentrations from the Clean Air Status and Trends Network (CASTNET), Interagency Monitoring of Protected Visual Environments (IMPROVE), and U.S. Environmental Protection Agency (USEPA) Chemical Speciation network (CSN) data and assumed deposition velocities (https://java.epa.gov/castnet/epa_jsp/sites.jsp; <http://vista.cira.colostate.edu/Improve/improve-program/>; <https://www3.epa.gov/ttnamti1/speciepg.html>; USEPA, 2015). Many studies have been done to characterize processes that affect dry deposition of Nr to snow-covered surfaces and atmospheric gas exchange with snow on the ground (Cadle et al., 1985; Johansson and Granat, 1986; Dibb et al., 1998; Erisman et al., 1994; Munger et al., 1999; Domine and Shepson, 2002; Beine et al., 2003 and 2005). A range of deposition velocities and deposition resistance values can be estimated for a variety of air pollutants and land surface types, including Nr species, and these are incorporated into dry deposition models (Wesley, 1989; Wesley and Hicks, 2000). Estimation of deposition velocities (Vd) is complicated by air temperature and snowpack surface conditions. For example, Cadle et al. (1985) measured an averaged velocity of 1.4 cm s^{-1} for gaseous nitric acid (HNO_3) deposition to snow for use in dry deposition models. Valdez et al. (1987) conducted chamber studies using snow of varying temperatures and age. They found sulfur dioxide (SO_2) Vd values of about 0.04 cm s^{-1} for temperatures below freezing and about 0.09 for temperatures around 0°C with surface melting. Their experiments pointed to the need to consider both snow age and liquid water content of the snowpack.

Modeling dry deposition

Many models represent the dry deposition velocity, V_d by resistances in series and parallel such as:

$$V_d(z) = \frac{1}{R_s(z-d) + R_b + R_c} \quad (1)$$

where: z is the reference height above the surface, d is usually 0.6-0.8 times the vegetation height, R_a is the aerodynamic resistance, R_b is the laminar layer resistance, and R_c is the canopy or surface resistance (Erisman et al., 1994). The canopy resistance is often further broken down as a combination of parallel resistances given by

$$R_s = \left(\frac{1}{R_{st}} + \frac{1}{R_w} + \frac{1}{R_g} \right)^{-1} \quad (2)$$

where: R_{st} is stomatal resistance, R_w is cuticular resistance, and R_g is ground resistance (Flechard et al., 2011). Accounting for snow-covered surfaces is often done by adjusting the ground resistance for snow or ice cover and by pollutant. Several studies (e.g., Johansson and Granat, 1986; Wesely, 1989, Bales et al., 1987, Valdez et al., 1987) have examined the role of temperature on the surface resistance. For example, Johansson and Granat (1986) found that resistance to deposition of HNO_3 to snow decreased with increasing temperature from greater than 5 s mm^{-1} at $-18 \text{ }^\circ\text{C}$ to about 1 s mm^{-1} at $-3 \text{ }^\circ\text{C}$. Warmer snow has a higher water content, which favors uptake by soluble compounds (Bales et al., 1987, Valdez et al., 1987). In Zhang et al. (2003), the resistance for snow-covered surfaces for SO_2 is a function of surface temperature while the resistance for ozone (O_3) is a fixed value. This parameterization is based on Erisman et al. (1994). In the Community Multiscale Air Quality Modeling System (CMAQ), the resistance is also a function of surface temperature, which is used to determine the water content of the snow, and includes the Henry's Law coefficient to account for variations in solubility among chemicals (DOI: 10.5281/zenodo.1212601).

Domine and Shepson (2002) calculated that an air volume equivalent to the entire atmosphere passes through the global snowpack on a time scale of ~ 3 months at a flow rate of $0.5 \text{ cm}^3 \text{ s}^{-1}$ due to wind pumping of the snowpack surface. They also reported that solar irradiation of the snowpack causes emission of nitrous acid (HONO) and subsequent photolysis that produces gas-phase hydroxide ion (OH) and NO_x , a bi-directional process not accounted for in Nr deposition modeling.

Dry deposition of particulates to the snowpack is another process that could be incorporated into Nr deposition models. Major dust-deposition events have been documented in snow pit observations and snowpack samples (Clow et al., 2016) with sources of the dust being both regional and from long-range transport (Kumar et al., 2016). Dust deposition to snow has been shown to reduce albedo, causing premature warming of the snowpack or "snow aging effect" (Conway et al., 1996; Motoyoshi et al., 2005; Aoki et al., 2006). Not only can this add

particulate Nr to the snowpack, but also could alter the seasonal reactivity of the snowpack surface (Domine and Shepson, 2002).

Future Research

An improved understanding of the processes that affect Nr in snow-covered surfaces is needed for appropriate parameterization of atmospheric deposition models. Improvements in wet- and dry- deposition monitoring techniques that provide accurate representation of Nr deposition in and to snow also are needed. Collection and analysis of continuous records for gaseous and particulate Nr in ambient air, fluxes measured by eddy covariance and other surface meteorological data in combination with co-located measurements of wet and dry Nr deposition in a variety of precipitation regimes also are needed.

Many practical improvements in monitoring technology and techniques are possible to obtain more representative measurements of wet deposition as snow. Suggestions for improvement of NADP data validation, completeness criteria, and precipitation weighting of chemical concentration data are presented herein (See Section **3.1.2.1. Wet deposition annual precipitation-weighted mean concentrations from incomplete time series: Influence of completeness criteria, data validation, and data substitution methods**). Those suggestions are focused on collecting a more complete record of valid samples, especially when automated wet-deposition collector performance is impacted by extreme winter weather. In addition, a method could be developed for collection of weekly bulk (i.e. wet-plus-dry deposition in same container) snow samples in containers continuously open to the sky and co-located with NADP sites to be used in cases when NADP samples are missed due to equipment failure. Development of such a method would require quantification of the differences between weekly bulk-sample concentrations and valid NADP sample concentrations.

Williams et al. (1998) showed how NADP snow collection at Niwot Ridge, CO, was positively biased by wind redistribution of previously deposited snow. This phenomenon is more common at high-altitude sites with large fetch and strong winds. Williams et al. (1998) used an independent, nearby precipitation gage that was not impacted by wind-redistributed snow to correct Niwot Ridge snow-deposition measurements. Wind-shielded wet-deposition collectors also could help limit wind-blown secondary deposition of snow (Wetherbee and Rhodes, 2013), but extreme weather conditions can nullify the benefits of such shielding (Bigelow et al., 1990). Additionally, weekly sampling and chemical analysis of the snow surface layer for Nr could be done at NADP sites to quantify dry deposition to snow. Weekly snow surface -minus- concentration differences could be evaluated as an estimate of the dry deposition component of Nr or to help calibrate bulk deposition measurements. A similar approach has been used to investigate deposition to the epilimnion of lakes (Shaw et al., 1989). Bulk snow-surface samples could also help identify wind resuspension and secondary deposition events and the effects of throughfall on snow chemistry.

Clow et al. (2015) measured throughfall deposition using bulk collectors that were fitted with IER columns, which were used to augment summer deposition data for Rocky Mountain National Park. The IER methodology for collection of throughfall Nr was developed in many studies by Mark Fenn (Fenn et al., 2002; 2003; 2004). Extensive network application of this technology could be implemented across the NADP and CAPMoN networks to obtain geographic variability and seasonality of Nr in bulk throughfall. However, melted snow can refreeze in the collectors and limit their performance. Clow et al. (2015) found that snowpack sampling was more accurate for quantification of winter wet-plus-dry Nr deposition. Nonetheless, IER sampling could be especially useful to fill gaps in the snow chemistry records by collecting bulk deposition samples between the time of snow pit sampling and the actual end of the snow season. Such IER sampling would also augment snow-chemistry data records for other major ion solutes in addition to Nr species.

Another unmonitored component of wet deposition at high altitudes is rime ice, which is a form of occult deposition that occurs when supercooled cloud water is intercepted by vegetation and the land surface. Ferrier et al. (1995) found that concentrations of NO_3^- in rime ice were nearly 4 times higher than in snow deposited over the same period on Cairngorm Mountain, Scotland. They also noted that potential surface reactions of Nr species may increase natural ionic enrichment of rimed snowpack surfaces.

Additional gaseous Nr monitoring is needed, especially in high-altitude environments. Expansion of the NADP Ammonia Monitoring Network (AMoN) to gather more complete spatial coverage of ambient gaseous NH_3 would improve estimation of its adsorption by snow (<http://nadp.slh.wisc.edu/AMoN/>, accessed May 25, 2017). Passive sampler methods for monitoring other Nr species (e.g., NO_2 , HNO_3) in remote, high-altitude areas would improve the spatial coverage of Nr dry deposition measurements. Deployment of this type of sampling will help define the seasonality of gaseous Nr fluxes. Of course, such measurements need to be coupled with refined estimates of deposition velocities.

Continued evaluation of open-path eddy covariance measurements of NH_3 flux also could serve to expand continuous, ambient NH_3 flux monitoring (Sun et al., 2015) as well as flux of oxidant species such as O_3 and NO_2 (Stocker et al., 1995). The Stocker et al. (1995) study showed diurnal variation in flux of NO_2 to snow. This study also indicated that the snow-surface resistance to oxidant deposition was 2.5 times greater for aged snow than for fresh snow. Whether these dynamics can be incorporated into models in meaningful ways that significantly improve total Nr deposition estimates is important to determine.

More sophisticated methods are needed to accurately monitor and model changes in Nr in snowpack from dry deposition and solar irradiation of the snow surface. Equally important is the Nr content and reactivity in the snowpack as it sheds meltwater to the ground and surface water, which occurs throughout the growing season in alpine areas (Bowman, 1992). Snowpack meltwater could be sampled with snow lysimeters to learn about how the snowpack chemistry changes during the melt season. Lysimeter data could be compared to snow surface chemistry

to evaluate how the snow surface changes as a reactive surface over time. Challenges include difficulty of constructing snowmelt lysimeters that are not contaminated by soil water, the sometimes-simultaneous occurrence of melt and new deposition that goes on during spring, and the extreme changes in snow surface (e.g., powder, wet, refrozen) that go on over short periods of time.

Additional work on snowpack emission of Nr at the snow surface in both gaseous and sublimated water phases, and the heterogeneous reactions of Nr species involving O₃ oxidation and photolysis are also needed. Algorithms that account for these processes can guide selection of appropriate depositional resistance factors and calculation of deposition velocities for predictive modeling.

References

Aoki, T., Motoyoshi, H., Kodama, Y., Yasunari, T.J., Sugiura, K., and Kobayashi, H., 2006, Atmospheric aerosol deposition on snow surfaces and its effect on albedo, SOLA 2: 13-16, DOI: 10.2151/sola.2006-004.

Bales, R.C., Valdez, M.P., and Dawson, G.A., 1987, Gaseous deposition to snow, 2. Physical-chemical model for SO₂ deposition, J. Geophys. Res., 92(D8): 9789-9799.

Baron, J.S., Rueth, H.M., Wolfe, A.M., Nydick, K.R., Allstott, E.J., Minear, J.T., and Moraska, B., 2000, Ecosystem responses to nitrogen deposition in the Colorado Front Range, Ecosystems 3: 352–368, DOI: 10.1007/s100210000032.

Beine, H.J., Dominé, F., Ianniello, A., Nardino, M., Allegrini, I., Teinilä, K., and Hillamo, R., 2003, Fluxes of nitrates between snow surfaces and the atmosphere in the European high Arctic, Atmos. Chem. Phys., 3: 335–346.

Beine, H.J., Amoroso, A., Esposito, G., Sparapani, R., Ianniello, A., Georgiadis, T., Nardino, M., Bonasoni, P., Cristofanelli, P., and Domine', F., 2005, Deposition of atmospheric nitrous acid on alkaline snow surfaces, Geophys. Res. Lett. 32(L10808), DOI: 10.1029/2005GL022589.

Bigelow, D.S., Denning, A.S., and Baron, J., 1990, Differences between nipher and alter shielded rain gages at two Colorado deposition monitoring sites, Environ. Sci. Tech. 24: 758-760.

Bowman, W.D., 1992, Inputs and storage of nitrogen in winter snowpack in an alpine ecosystem, Arctic and Alpine Res. 24(3): 211-215.

Brooks, P.D., and Williams, M.W., 1999, Snowpack controls on nitrogen cycling and export in seasonally snow-covered catchments, Hydrol. Process. 13: 2177-2190.

Burns, D.A., 2004, The effects of atmospheric nitrogen deposition in the Rocky Mountains of Colorado and southern Wyoming, USA—a critical review, Environ. Pollut. 127: 257-269.

Cadle, S.H., Muhlbaier-Dasch, J., and Mulawa, P.A., 1985, Atmospheric concentrations and the deposition velocity to snow of nitric acid, sulfur dioxide and various particulate species, *Atmos. Environ.* 19(11): 1819-1827.

Clow, D.W., Ingersoll, G.P., Mast, M.A., Turk, J.T., and Campbell, D.H., 2002, Comparison of snowpack and winter wet-deposition chemistry in the Rocky Mountains, USA: implications for winter dry deposition, *Atmos. Environ.* 36: 2337–2348.

Clow, D.W., Roop, H.A., Nanus, L., Fenn, M.E., and Sexstone, G.A., 2015, Spatial patterns of atmospheric deposition of nitrogen and sulfur using ion-exchange resin collectors in Rocky Mountain National Park, USA, *Atmos. Environ.* 101: 149-157.

Clow, D.W., Williams, M.W., and Schuster, P.F., 2016, Increasing aeolian dust deposition to snowpacks in the Rocky Mountains inferred from snowpack, wet deposition, and aerosol chemistry, *Atmos. Environ.* 146: 183-194.

Conway, H., Gades, A., and Raymond, C.F., 1996, Albedo of dirty snow during conditions of melt, *Water Resour. Res.* 32(6): 1713-1718.

Dibb, J.E., Talbot, R.W., Munger J.W., Jacob, D.J., and, Fan, S-M, 1998, Air-snow exchange of HNO_3 and NO_y at Summit, Greenland, *J. Geophys. Res.* 103(D3): 3475-3486.

Dominé, F., and Shepson, P.B., 2002, Air-snow interactions and atmospheric chemistry, *Science* 297(5586): 1506-1510, DOI: 10.1126/science.1074610.

Erismann, J.W., Van Pul, A., and Wyers, P., 1994, Parametrization of surface resistance for the quantification of atmospheric deposition of acidifying pollutants and ozone, *Atmos. Environ.* 28(16): 2595-2607.

Fenn, M.E., Haeuber, R., Tonnesen, G.S., Baron, J.S., Grossman-Clarke, S., Hope, D., Jaffe, D.A., Copeland, S., Geiser, L., Rueth, H.M., and Sickman, J.O., 2003, Nitrogen emissions, deposition, and monitoring in the western United States, *BioSci.* 53(4): 391-403.

Fenn, M.E., and Poth, M.A., 2004, Atmospheric pollutants and trace gases, monitoring nitrogen deposition in throughfall using ion exchange resin columns: A Field Test in the San Bernardino Mountains, *J. Environ. Qual.* 33: 2007–2014.

Fenn, M.E., Poth, M.A., and Arbaugh, M.J., 2002, A throughfall collection method using mixed bed ion exchange resin columns, *Sci. World J.* 2: 122-130, DOI: 10.1100/tsw.2002.84.

Fenn, M.E., Sickman, J.O., Bytnerowicz, A., Clow, D.W., Molotch, N.P., Pleim, J.E., Tonnesen, G.S., Weathers, K.C., Padgett, P.E., and Campbell, D.H., 2009, Methods for measuring atmospheric nitrogen deposition inputs in arid and montane ecosystems of western North America, in Legge, A.H. ed., *Developments in Environmental Science*, Vol. 9, chap. 8, Elsevier Ltd., DOI: 10.1016/S1474-8177(08)00208-8.

- Ferrier, R.C., Jenkins, A., and Elston, D.A., 1995, The composition of rime ice as an indicator of the quality of winter deposition, *Environ. Pollut.* 87: 259-266.
- Flechard, C. R., Nemitz, E., Smith, R. I., Fowler, D., Vermeulen, A.T., Bleeker, A., Erisman, J. W., Simpson D., Zhang, L., Tang, Y. S., and Sutton, M.A., 2011, Dry deposition of reactive nitrogen to European ecosystems: a comparison of inferential models across the NitroEurope network, *Atmos. Chem. Phys.* 11: 2703–2728.
- Gilliland, A.B., Butler, T.J., and Likens, G.E., 2002, Monthly and annual bias in weekly (NADP/NTN) versus daily (AIRMoN) precipitation chemistry data in the Eastern USA, *Atmos. Environ.* 36(33): 5197-5206.
- Ingersoll, G.P., Miller, D.C., Morris, K.H., McMurray, J.A., Port, G.M., and Caruso, B., 2016, Changing regional emissions of airborne pollutants reflected in the chemistry of snowpacks and wetfall in the Rocky Mountain region, USA, 1993–2012, *Water Air Soil Pollut.* 227: 94. DOI: 10.1007/s11270-016-2784-4.
- Johansson, C., and Granat, L., 1986, An experimental study of the dry deposition of gaseous nitric acid to snow, *Atmos. Environ.* 20(6): 1165-1170.
- Kuhn, M., 2001, The nutrient cycle through snow and ice, a review, *Aquat. Sci.* 63: 150–167, DOI: 1015-1621/01/020150-18.
- Kumar, B., Singh, S., Gupta, G.P., Lone, F.A., and Kulshrestha, U.C., 2016, Long range transport and wet deposition fluxes of major chemical species in snow at Gulmarg in north western Himalayas (India), *Aerosol Air Qual. Res.* 16: 606-617.
- Lawrence, G.B., Lovett, G.M., and Baevsky, Y.H., 2000, Atmospheric deposition and watershed nitrogen export along an elevational gradient in the Catskill Mountains, New York, *Biogeochem.* 50: 21-43.
- Motoyoshi, H., Aoki, T., Hori, M., Abe, O., and Mochizuki, S., 2005, Possible effect of anthropogenic aerosol deposition on snow albedo reduction at Shinjo, Japan, *J Meteorol. Soc. Japan*, 83A: 137-148.
- Munger, J.W., Jacobs, D.J., Fan, S-M., and Colman, A.S., 1999, Concentrations and snow-atmosphere fluxes of reactive nitrogen at Summit, Greenland, *J. Geophys. Res.* 104 (D11): 13,721-13,734.
- Nanus, L., Clow, D.W., Saros, J.E., Stephens, V.C., and Campbell, D.H., 2012, Mapping critical loads of nitrogen deposition for aquatic ecosystems in the Rocky Mountains, USA: *Environ. Pollut.*, 166: 125-135, DOI: 10.1016/j.envpol.2012.03.019.
- Pardo, L.H., Fenn, M.E., Goodale, C.L., Geiser, L.H., Driscoll, C.T., Allen, E.B., Baron, J.S., Bobbink, R., Bowman, W.D., Clark, C.M., Emmett, B., Gilliam, F.S., Greaver, T.L., Hall, S.J., Lilleskov, E.A., Liu, L., Lynch, J.A., Nadelhoffer, K.J., Perakis, S.S., Robin-Abbott, M.J., Stoddard, J.L., Weathers,

K.C., Dennis, R.L., 2011, Effects of nitrogen deposition and empirical nitrogen critical loads for ecoregions of the United States, *Ecol. Appl.*, 21(8): 3049-3082.

Pleim, J. and Ran, L., 2011, Surface flux modeling for air quality applications, *Atmosphere* 2: 271-302; DOI: 10.3390/atmos2030271.

Shaw, R.D., Trimbee, A.M., Minty, A., Fricker, H., and Prepas, E.E., 1989, Atmospheric deposition of phosphorous and nitrogen in central Alberta with emphasis on Narrow Lake, *Water Air Soil Pollut.* 43: 119-134.

Sirois, A., Vet, R., and Lamb, D., 2000, A comparison of the precipitation chemistry measurements obtained by the CAPMoN and NADP/NTN Networks. *Environ. Monit. Assess.*, 62: 273-303.

Stocker, D.W., Zeller, K.F., and Stedman, D.H., 1995, O₃ and NO₂ Fluxes over snow measured by eddy correlation, *Atmos. Environ.* 29(11): 1299-1305.

Sun, K., Tao, L., Miller, D.J., Zondlo, M.A., Shonkwiler, K.B., Nash, C., and Ham, J.M., 2015, Open-path eddy covariance measurements of ammonia fluxes from a beef cattle feedlot, *Agricul. Forest Meteorol.* 213: 193–202.

U.S. EPA, 2015, 2013 National Monitoring Programs Annual Report (UATMP, NATTS, CSATAM), October 2015 Final Report, <https://www3.epa.gov/ttnamti1/files/ambient/airtox/2013nmpreport.pdf>.

U.S. EPA, 2018, Community Multiscale Air Quality Model (CMAQ), <https://www.epa.gov/cmaq>, DOI: 10.5281/zenodo.1212601.

Valdez, M.P., Bales, R.C., Stanley, D.A., Dawson, G.A., 1987, Gaseous deposition to snow, 1. Experimental study of SO₂ and NO₂ deposition, *J. Geophys. Res.*, 92(8): 9779-9787.

Wesley, M.L., 1989, Parameterization of surface resistances to gaseous dry deposition in regional-scale numerical models, *Atmos. Environ.* 23(6): 1293-1304.

Wesley, M.L., and Hicks, B.B., 2000, A review of the current status of knowledge on dry deposition, *Atmos. Environ.* 34: 2261-2282.

Wetherbee, G.A., and Rhodes, M.F., 2013, Effects of equipment performance on data quality from the National Atmospheric Deposition Program/National Trends Network and the Mercury Deposition Network, U.S. Geological Survey Open-File Report 2013-1031, pp 31-42.

Wetherbee, G.A., Shaw, M.J., Latysh, N.E., Lehmann, C.M.B., and Rothert, J.E., 2010, Comparison of precipitation chemistry measurements obtained by the Canadian Air and Precipitation Monitoring Network and National Atmospheric Deposition Program for the period 1995–2004, *Environ. Monit. Assess.* 164: 111. DOI: 10.1007/s10661-009-0879-8.

Williams, M.W., Bardsley, T., and Ridders, M., 1998, Overestimation of snow depth and inorganic nitrogen wetfall using NADP data, Niwot Ridge, Colorado, *Atmos. Environ.* 32(22): 3827-3833.

Zhang, L., Brook, J.R., and Vet, R., 2003, A revised parameterization for gaseous dry deposition air-quality models, *Atmos. Chem. Phys.*, 3: 2067-2082.

Zhang, L., Jacob, D.J., Knipping, E.M., Kumar, N., Munger, J.W., Carouge, C.C., van Donkelaar, A., Wang, Y. X., and Chen, D., 2012, Nitrogen deposition to the United States: distribution, sources, and processes, *Atmos. Chem. Phys.*, 12: 4539–4554.

3.1.1.6. Occult deposition: what we know, don't know, and should really know

Selma S. Isil, Christopher M. Rogers

Wood Environment & Infrastructure Solutions, Inc., Newberry, FL

Research topic summary

Development of meaningful critical load values and total Nr budgets for high-elevation and fog impacted sites requires reliable cloud and fog water deposition estimates. However, the cost and labor intensity of cloud water sample collection has made long-term studies at single and multiple sites or on a network-wide basis extremely difficult. Two small cloud water monitoring networks existed in the late 1980s and the mid-1990s through 2011. Both of these efforts were discontinued due to the cost of operating at remote locations (mountain tops) with inadequate infrastructure in place and intensive labor associated with reaching and working at such locations. These obstacles have limited the collection of cloud water samples, and most of the data have been collected during the growing season at eastern U.S. locations. National monitoring infrastructure is insufficient to conduct long-term mountain-top measurements, but more effort could perhaps be focused in a few key locations, such as in the Rocky Mountain west and Whiteface Mountain in the Adirondack Mountains of New York State, where intensive research efforts are already underway due to the sensitive nature of their high elevation ecosystems. It is important to derive empirical models of cloud deposition as a fraction of total deposition in such areas. There is also a need to investigate the role of cloud drop size, which can impact the chemical composition of cloud water as well as deposition rates. The two past cloud monitoring networks did not collect information on cloud drop size.

Current understanding of fog formation, transport and its role in hydrogeological and biogeochemical cycles is lacking (Weathers et al., 2014) due, in part, to the lack of a concerted interdisciplinary approach to the problem. Historically, fog researchers have come from many different disciplines and agencies, and data and research results are scattered across journals and mediums. This issue was recently undertaken with the publication of a white paper (Weathers et al., 2014) as a starting point to aid the fog research community in identifying common research objectives. The fog community is also looking to engage in further dialogue with existing research institutions, scientific communities and funding agencies to explore opportunities for collaboration.

Since fog impaction occurs in more accessible areas than cloud deposition, near-term steps could focus more effort on fog deposition in coastal areas. A long-term step for both cloud and fog deposition could be to increase the frequency or technical rigor of measurements to characterize process-level chemistry, which could then perhaps be extrapolated to other locales and inform improvements to simulation of occult deposition in chemical transport models (CTMs).

Introduction

Atmospheric pollution is deposited to the environment via a number of physical and chemical mechanisms. In high elevation environments, cloud water samples are typically 5 to 20 times more acidic than rain water (Mohnen and Vong, 1993; Mohnen et al., 1990; Vong et al., 1991) and the interception of cloud water by spruce and fir trees and other vegetation in the Appalachian Mountains has been shown to be a major deposition pathway (Aneja and Kim, 1993; Miller et al., 1993; Lindberg, 1992; Lovett and Kinsman, 1990). Deposition of pollutants by cloud water exceeds deposition by precipitation and dry deposition in high elevation settings from North Carolina to Maine (Isil et al., 2000). The large loading of pollutants in such environments is due to a combination of factors such as high frequency of cloud immersion, high wind speeds, orographic enhancement of precipitation, and large leaf areas of tree species typical of these environments (Miller and Friedland, 1999). Deposition of Nr in fog or cloud water is also a very important N input pathway in forests along the coast of California (redwood forests), the Transverse ranges of southern California (i.e., inland from LA), and in the western Sierra Nevada (Collett et al., 1990; Fenn et al., 2000; Templer et al., 2015).

The decline of red spruce (*Picea rubens*) in the northeastern U.S. in the late 1980s was in part attributed to the reduction in cold tolerance by these species as a result of exposure to acidic cloud water (Eager et al., 1992). Impacts specific to increased Nr deposition have been studied mostly in the Rocky Mountains and in Europe (Lovett and Tear, 2008). Some of these impacts on alpine and subalpine regions in the Rocky Mountain National Park (RMNP) include changes in the chemistry of old-growth Engelmann spruce forests (Rueth and Baron, 2002), shifts in population of lake diatoms (Baron et al., 2000), excess nitrogen leakage into lakes and streams during certain times of the year, and alterations in biogeochemical cycling associated with increased microbial activity in high elevation soils and taluses (Campbell et al., 2000, 2002). It has also been suggested that high levels of Nr deposition or long-term accumulation may cause a decrease in plant species diversity as nitrophilous species start to dominate (Bowman et al., 2006). Given the overall similarity among plants of alpine ecosystems in the Rockies and the eastern U.S., Nr deposition is most likely damaging high-elevation ecosystems in the eastern U.S. as well. Deposition loads of 10 to 40 kg N/ha/year in high-elevation areas in the East are much higher than in the West (Lovett and Tear, 2008). Therefore, it is possible that productivity and species shifts have already occurred in eastern alpine ecosystems.

State of the science

Results from MADPRO

Analytical results from the Mountain Cloud Chemistry Project (MCCP) and the Mountain Acid Deposition Program (MADPRO) show that in locations where cloud impaction occurs with regularity cloud deposition is the biggest contributor to pollutant loading. Generally, significant cloud impaction occurs at altitudes of 800 m and greater and at such elevations cloud water samples are typically 5 to 20 times more acidic than rain water. MADPRO results for Clingmans Dome, Tennessee (CLD303) indicate that cloud water concentrations of the major ions of SO_4^{2-} , NO_3^- , NH_4^+ and H^+ showed a general decreasing trend after 2001 (Figure 1). The exception to this decreasing trend was the 3-year period from 2005 through 2007 when all major ion concentrations, except for H^+ , increased. Regardless of the inter-annual variations in

concentrations, the 3-year mean concentrations of SO_4^{2-} , NO_3^- , NH_4^+ and H^+ from 2009 through 2011 were lower by 49, 39, 12 and 88% , respectively, compared to the 3-year mean concentrations from 2000 through 2002. Precipitation nitrate concentrations at the National Trends Network/National Atmospheric Deposition Program (NTN/NADP) site TN11 at Elkmont, TN followed the same general pattern of increases and decreases as cloud water concentrations (Figure 2), especially after 2004 (Isil et al., 2017).

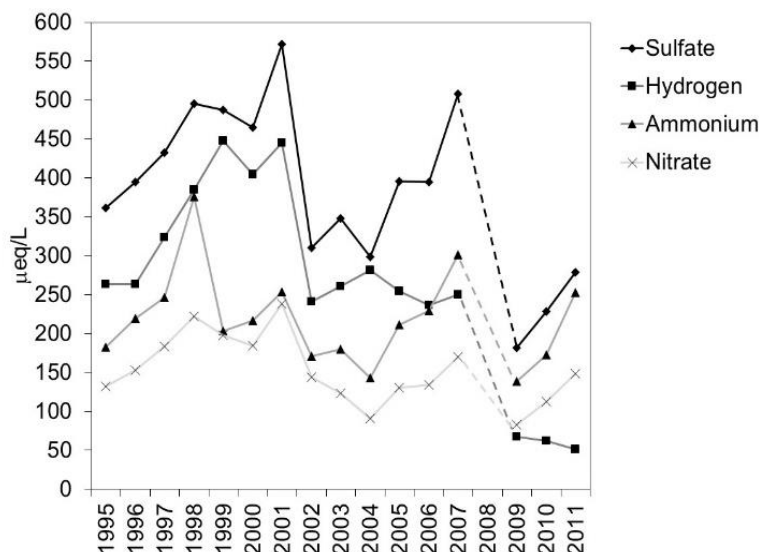

Figure 1. Mean major ion concentrations of cloud water samples at CLD303, TN, 1995-2011.

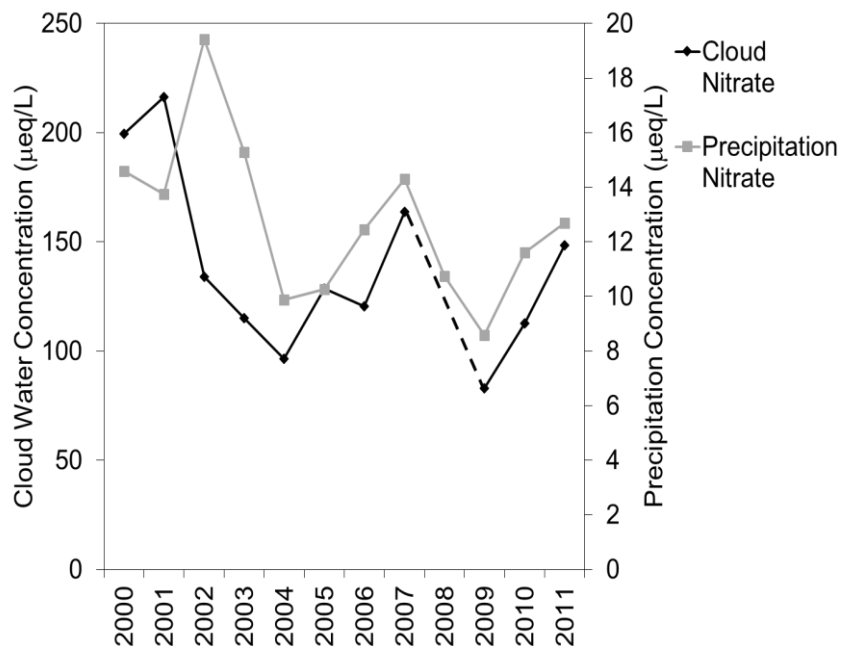

Figure 2. Mean seasonal (June – September) cloud water (CLD303, TN) versus mean seasonal precipitation (TN11, TN) nitrate concentrations.

Comparison of the CLD303 data with data from the cloud water monitoring site at Whiteface

Mountain, New York (WFM300) show that NO_3^- concentrations were consistently higher at CLD303 by approximately 45% (Figure 3). The overall downward trend in concentrations observed at CLD303 was also evident at WFM300 (Isil et al., 2017) although this trend diverges in 2010 and 2011. The downward trend at WFM300 continued whereas CLD303 nitrate concentrations increased during these two years.

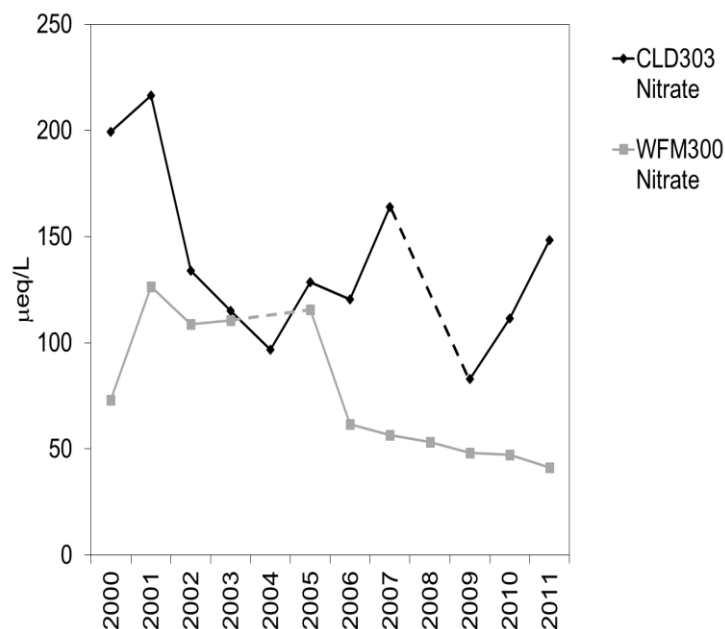

Figure 3. Mean seasonal (June through September) cloud water nitrate concentrations for CLD303, TN and WFM300, NY 2000-2011.

Cloud water deposition estimated by the CLOUD model (Lovett, 1984; Lovett and Reiners, 1986) showed declines in 3-year average deposition estimates of 71, 70, 49 and 88% for SO_4^{2-} , NO_3^- , NH_4^+ and H^+ , respectively, from 2000-2002 to 2009-2011 (Figure 4). Comparison with wet deposition data from TN11 (Figure 5) show that SO_4^{2-} deposition estimates for cloud water and precipitation follow a similar pattern from 2004 onward. The NO_3^- deposition estimates were more variable.

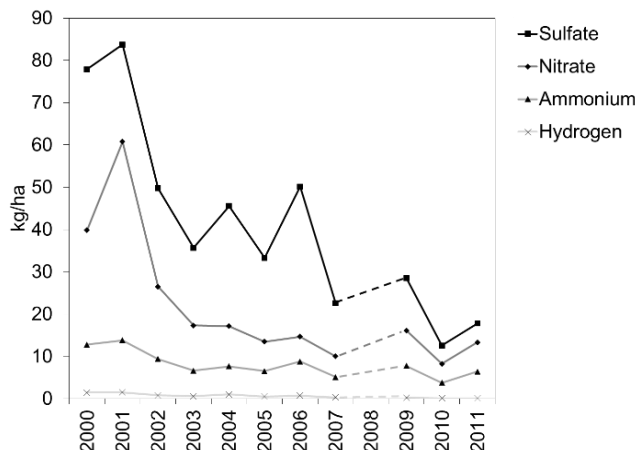

Figure 4. Seasonal (June through September) deposition estimates from the CLOUD model for major ions in cloud water CLD303, TN 2000-2011.

Even though concentrations and depositions at CLD303 have declined, cloud water Nr deposition still accounted for most of the total deposition (Figure 5). Cloud water Nr deposition composed approximately 69 to 90% of the total deposition. Nr deposition estimates decreased for cloud water and dry components, but there has been no discernible change in the wet Nr component since 2000.

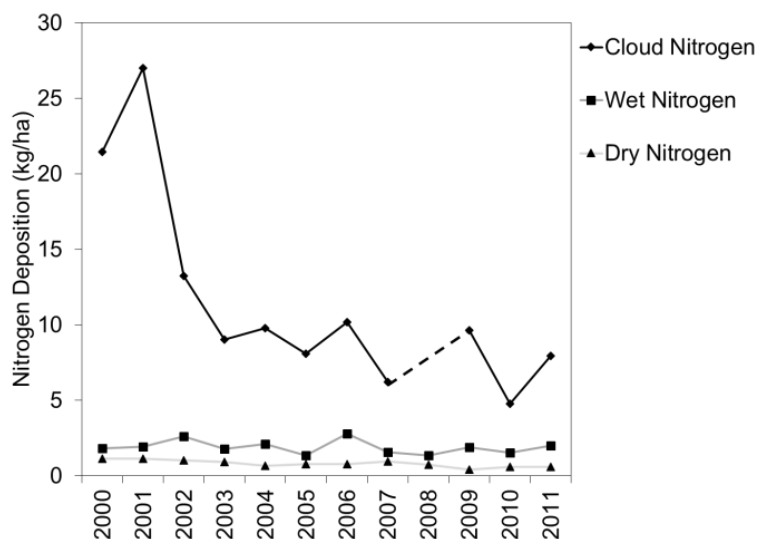

Figure 5. Seasonal (June through September) total Nr deposition components for CLD303, TN 2000-2011.

The Tennessee Valley Authority (TVA) reported that emissions from TVA-operated power plants generally declined from 2000 through 2011 with some exceptions, such as 2010, when emissions increased (EPA, 2016). Cloud water concentration and deposition trends for SO_4^{2-} and NO_3^- generally mirror the emission trends for SO_2 and NO_x (Figure 8). However, there are

exceptions. For example, in 2011 emissions decreased, but both concentrations and deposition estimates increased. A possible reason for such exceptions may be the influence of cloud liquid water content (LWC) and weather conditions, which usually vary from season to season and can affect the concentrations of pollutants within a cloud.

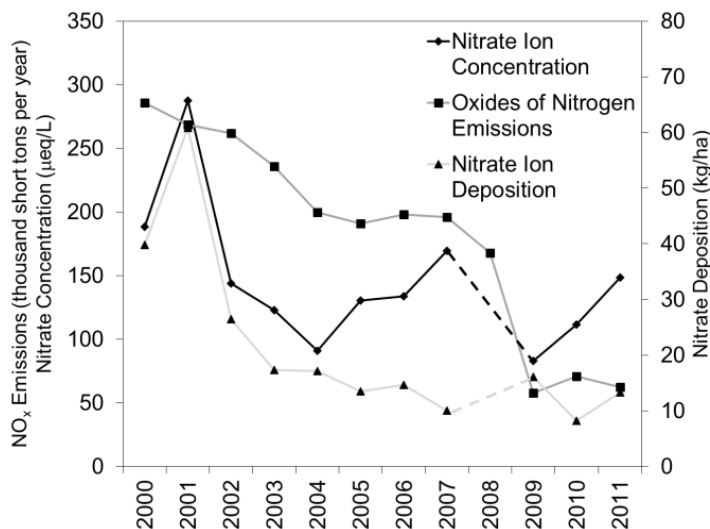

Figure 6. Seasonal cloud water NO_3^- concentrations and deposition estimates and TVA annual NO_x emissions, 2000-2011.

Other cloud water studies

U.S.

Cloud water was sampled in the fall of 1985 and spring of 1986 in Sequoia National Park (SNP) located in the southern Sierra Nevada Mountains of California (Collett, et al 1989). Comparison of concentrations from SNP with two sites in the northeast (Whiteface Mountain, New York and Mt Moosilauke, New Hampshire) showed that SNP cloud water was generally much less acidic. The difference between SNP and Whiteface Mountain was mostly attributed to the smaller input of bases at Whiteface as evidenced by lower NH_4^+ cloud water concentrations with respect to SNP. The levels of cloud water NH_4^+ were similarly low at Mt. Moosilauke, but part of the higher acidity at this site was attributed to larger acid inputs. The concentrations were also compared to cloud water samples collected at Laguna Peak, an elevated site along the southern California coast (Munger, et. al., 1989). The NH_4^+ concentrations at both sites were comparable, but concentrations of SO_4^{2-} and NO_3^- were higher at Laguna Peak resulting in sample pH values that averaged nearly 1.5 units less that observed at SNP.

Collett et al. (1990) continued sample collection at SNP in late 1987 and again in late 1988 and sampled an additional site in Yosemite National Park during these time periods. In both parks, the chemical composition of cloud water was dominated by NO_3^- , SO_4^{2-} and NH_4^+ . When samples were collected simultaneously from both sites, the Yosemite samples were more acidic than SNP samples. The role of cloud water neutralization inputs by NH_3 was clearly observed.

The authors concluded that, in the absence of large NH_3 inputs, sample pH values in the Sierra Nevada's may fall below 3.0.

Bormann et al. (1989) collected cloud water from two Pacific Northwest sites, Marys Peak, Oregon and a site near Juneau, Alaska. Cloud water samples from both sites were chemically similar and much more dilute than sites in the eastern U.S.

Puerto Rico

Cloud water analytical studies are especially lacking in tropical and remote regions. Gioda, et al. (2009) have conducted cloud water sampling activities in Puerto Rico as part of the Puerto Rico Aerosol and Clouds Study (PRACS). Their results showed that the most abundant species measured in their samples were sodium (Na^+) and chloride (Cl^-) which was consistent with the proximity of the sampling site to the ocean. The $\text{SO}_4^{2-}/\text{Na}^+$ and $\text{NO}_3^-/\text{Na}^+$ ratios, compared to sea water, were much higher, along with a decrease in pH from 6.1 to 4.9, when air masses arrived from North America. These differences were attributed to long range transport of NO_3^- and SO_4^{2-} derived mainly from SO_2 and NO_x emissions in North America.

Europe

Numerous cloud and cloud water investigations have been carried out in Europe for different parameters and processes over the past few decades. In Germany, Acker et al. (2002) have studied cloud physical and chemical processes in low clouds at Mt. Brocken, while Plessow et al. (2001) conducted a time study of trace elements and major ions at the same location. Bruggemann et al. (2005) conducted a hill cap cloud experiment to investigate changes of major particulate inorganic components and a wide spectrum of organic species. Baltensperger et al. (1998) studied scavenging of atmospheric constituents in mixed phase clouds at Jungfraujoch, a high-alpine site in Switzerland, and Oberholzer et al. (1992) looked at in-cloud scavenging of gases and aerosols. In Sonnblick, Austria, Kasper et al. (1998) investigated the scavenging efficiency of lead (Pb) and SO_4^{2-} in supercooled clouds, and Hitzenberger et al. (2000) have looked at black carbon and other species. Dore et al. (2001) studied precipitation and cap cloud chemistry at Holme Moss in the southern Pennines in England, and Voisin and Legrand (2000) have looked at scavenging of acidic gases and NH_3 in mixed liquid-solid water clouds at Puy de Dome mountain in France.

South America/Pacific

While marine cloud chemistry measurements are globally scarce, even less is known about cloud composition in the Southern hemisphere. The stratiform cloud deck off the west coast of South America is one of the largest and most persistent cloud features on the planet. Clouds of this region have an important impact on the earth's radiative balance and other phenomena such as tropical precipitation and westward propagating Rossby waves (Wang et al. 2005).

Weathers and Likens (1997) collected cloud water samples from two sites in southern Chile between 1987 and 1994. Precipitation chemistry from this region of Chile is thought to reflect natural rather than anthropogenic processes. Results of cloud water sampling from remote

southern Chile was dominated by ions commonly associated with sea salt. An unexpected result was the relatively large contribution of inorganic Nr (8%) to the total ionic strength of samples. Mean inorganic Nr concentrations from the Chilean sites were higher than those from cloud water samples from sites in the Pacific northwest. Similar results compared to other cloud water studies were also observed in Chile in that cloud water chemistry was, on the average, many times more concentrated than rainwater collected at a nearby precipitation collection site. However, the cloud:rain enhancement in southern Chile was extraordinarily high for some ions. For example, NH_4^+ concentrations in cloud water were 80 times greater than rain water. Calcium and NO_3^- cloud versus rain enhancements were also very high. The high concentrations of Nr in the cloud water are very interesting especially because Nr is thought to be a limiting nutrient in the Southern Hemisphere. Several researchers (Likens et al. 1990; Galloway et al. 1996; Hedin et al. 1995) have postulated that Nr deposition via precipitation to temperate ecosystems in southern Chile is among the lowest in the world. The results from this study suggest that cloud deposition to such ecosystems may be a very important source of Nr.

As part of the VAMOS Ocean-Cloud-Atmosphere-Land Study Regional Experiment (VOCALS-Rex), Benedict et al. (2012) collected samples of cloud water from the Chilean coast from October to November 2008 in order to improve understanding of marine cloud composition and the capacity of regional clouds for aqueous SO_4^{2-} production. Samples were collected close to shore where anthropogenic sources were more likely to influence air mass composition as well as far off the coast in more pristine environments. Cloud water chemistry measurements showed that the coastal area was polluted while cleaner air masses were sampled further from shore. K^+ and Mg^{2+} were found to be present in proportions similar to sea water, SO_4^{2-} , NO_3^- and Ca^{2+} were enriched, and Cl^- was depleted. Measurements of cloud water pH and key oxidants and catalysts indicated that aqueous phase S oxidation in regional clouds was dominated by the hydrogen peroxide (H_2O_2) pathway.

Asia

In China, cloud water studies started in the 1980s, and some limited information was gathered at several mountainous sites in southern China (Wang and Xu, 2009). Studies of Chinese cloud chemistry have been rare in the following three decades due to shortage of equipment and research funding. As part of China's national Basic Research Program on Acid Rain, Guo et al. (2012) conducted five intensive cloud studies from 2007 through 2008 at the summit of Mount Tai, the highest mountain in the North China Plain. Results showed that the volume weighted mean pH of all samples was 3.86 and that more than half the samples were strongly acidified ($\text{pH} < 4.5$). The dominant ion species were NH_4^+ , SO_4^{2-} , NO_3^- and Ca^{2+} . Back trajectory analysis showed that 87% of air masses originated from southern China and these masses were more acidic. Air masses that originated from northern China usually yielded more Ca^{2+} and had higher pH values.

The importance of cloud drop size

In early cloud water studies, the collectors used generally collected 'bulk' samples, whether

these samples were event, daily or hourly bulk samples. This type of collection scheme assumes that drops within a cloud possess a uniform composition. From a theoretical basis (Ogren and Charlson, 1992), there are several reasons for cloud drops to be chemically heterogeneous: the chemically heterogeneous nature of the particles upon which cloud drops form, varying growth rates across the drop size spectrum, and differences in rates of soluble gas uptake. Numerous researchers have shown differences in the chemical composition of cloud water with drop size (Munger et al., 1989; Ogren et al., 1989; Noone et al., 1988; Collett et al., 1993, 1994, 1995, 1999; Rao and Collett, 1995; Bator and Collett, 1997; Menon et al., 2000; Moore et al., 2004).

Studies by Collett and his associates have shown that smaller cloud drops tend to be more acidic and contain higher concentrations of accumulation mode aerosol species (SO_4^{2-} , NO_3^- , and NH_4^+). Larger, mechanically generated particles, like soil dust and sea salt, are usually enriched in larger cloud drops. Differences between the composition of small and large cloud drops suggest enhanced rates of S oxidation relative to rates predicted by results of bulk cloud water chemistry analyses.

Menon et al. (2000) have found that chemical heterogeneity in cloud drops varied between events. Small drops were more acidic for events associated with marine and polluted air masses but not for continental air masses. Small drops showed higher solute concentrations if clouds were influenced by frontal systems, whereas slightly higher concentrations were seen in large drops if events were caused by orographic forcing.

According to Bator and Collett (1997), chemical heterogeneity across the cloud drop size spectrum can impact conclusions about the role of clouds and fog in a number of processes that are highly dependent on droplet size. These processes include cloud water deposition to forests and other vegetation; cloud and fog water deposition to materials; and respiration of fog drops. Differences between the chemical composition of large and small drops could significantly impact chemical deposition by these processes. Aerosol species are incorporated into precipitation based largely on the extent to which cloud drops with these species are incorporated into growing precipitation particles. Accretional growth of precipitation is drop size dependent with larger drops being captured more efficiently. Thus, dependence of cloud drop chemistry on drop size can influence the scavenging of chemical species by precipitation (Collett et al., 1991; Devulapalli and Collett, 1994).

Fog water studies

Fog chemistry has been studied since the beginning of the 20th century (Herckes et al., 2015), but research did not intensify until the late 1980s in conjunction with acid rain research, cloud water collection efforts, and the discovery of highly acidic fog. Numerous field studies have investigated the composition of fog in the U.S., Asia, and Europe.

Radiation fogs

Even at low elevations, deposition of pollutants by acidic fog is a contributor to pollution exposure as demonstrated by the Great Smog of 1952 in London during early December that killed thousands (www.metoffice.gov.uk ,accessed October 4, 2018). Fog research, particularly of radiation fogs, have centered on Italy's Po valley and California's Central valley. Radiation fogs are formed by the cooling of land after sunset. Fog forms when the cooled and stabilized air reaches the saturation point. The Po Valley and the Central Valley experience large emissions from extensive agricultural activities and activities associated with dense populations. Both regions also share topographical and climatological patterns that facilitate radiative fog formation (Herckes et al., 2015). In the Central Valley, three decades of research results show that fog chemistry in the valley is dominated by the $\text{NH}_3\text{-HNO}_3\text{-NH}_4\text{NO}_3$ system with SO_4^{2-} being a minor component, especially, and more recently, in the more northern locations. There is a regional gradient in fog occurrence with less fog and lower density or LWC fog in the southern part of the valley. Fogs in the southern valley have higher solute loadings and lower pH with respect to more northern locations in the valley (Bakersfield versus Davis and Fresno). Herckes et al. (2015) conclude that LWC values of fogs appear to have decreased over recent years. An airport visibility assessment of fog frequency shows that dense fogs (visibility of less than $\frac{1}{4}$ mile) have decreased by approximately 50% over the past 30 years. The ramifications of less fog formation could have many serious impacts.

Coastal fogs

Coastal fog, or stratocumulus fog, is commonplace in many marine geographies, notably the west coasts of California, Chile and Africa. In most Pacific coastal systems, fog is the primary, and sometimes the only, source of water for plants and humans. It is a key moderator of local and regional climate, and influences the productivity of near-coastal terrestrial ecosystems (Weathers et al., 2014). In California, coastal redwood forests receive fog water in the summer months. Without fog water, the summer months would be a time when the soils would be dry, and the vegetation would experience water deficits since only less than 3% of the annual precipitation occurs during the summer (Ewing et al., 2009; Hiatt, Fernandez and Potter, 2012). Dawson (1998) has shown that uptake of fog water by redwood trees during the summer months represents up to 45% of the water source for annual transpiration. Since coastal redwoods grow in a band bordering the ocean, it is possible that coastal climatic phenomena, such as fog, may be responsible, at least in part, for their distribution (Noss, 2000).

Concentrations of Nr in the fog water of redwood forests, as well as in other fog-inundated systems around the world, are significantly greater than those in rainfall (Weathers et al., 1988; Weathers and Likens, 1997; Weathers et al., 2000; Gonzalez et al., 2011). Ewing et al. (2009) have shown that Nr from canopy throughfall during the summer months in redwood forests provides up to 21% of annual Nr inputs to the forest floor. Since fog flows horizontally, instead of vertically like precipitation, trees at the coastal edge of stands can get up to seven times more water and Nr via throughfall to the forest floor compared to interior trees (Ewing, et al. 2009). Fenn et al. (2000) have estimated that Nr deposition contributed 35 percent of the annual deposition at a research site in the western San Bernardino Mountains (SBM) compared to 13 percent at a site in the eastern edge of the SBM. Ionic concentrations of fog water, fog-

water deposition fluxes, fog occurrence, and fog density were all higher at the western SBM site. Templer et al. (2015) studied fluxes and a stable isotope of nitrogen (^{15}N) in a coastal California redwood forest and showed that substantial inputs of NO_3^- to the forest floor come from the canopy as throughfall, especially at the forest edge. These inputs are directly from atmospheric inputs (fog or rain) rather than in-canopy nitrification.

Drop-size dependent fog water composition

Noone et al. (1988) and Hoag et al. (1999) have shown that some species are enriched in small droplets (less than 15 micrometer diameter) while others are enriched in large droplets. Since larger droplets deposit faster than smaller droplets, species that are more concentrated in larger droplets will be removed from the atmosphere faster. Observations of deposition velocities in San Joaquin Valley fog by Waldman (1986) and Collett et al. (2001) indicate a difference in deposition between species. Different species were also observed to have different deposition velocities during the 1995 Integrated Monitoring Study (IMS95). NO_3^- deposited the slowest because of its existence in smaller fog droplets, NH_4^+ had the highest deposition velocity, and the SO_4^{2-} deposition velocity was in between the two (Hoag et al., 1999).

Current collection methods

Cloud water collectors

Cloud water samples are currently collected by active or passive samplers. Passive collectors depend upon the local wind to give drops enough inertia to impact upon the collection strings, while active collectors use pumped flow to achieve the same results of impaction upon collection strings. There are a wide variety of passive and active collectors. The MCCP and MADPRO programs deployed the Atmospheric Sciences Research Center (ASRC) passive collector. Collett and colleagues have used several models of active collectors: the Caltech Active Strand Cloud Water Collector (CASCC), the size-fractionating Caltech Active Strand Cloud Water Collector (sf-CASCC), and the Colorado State University (CSU) 5-stage Cloud Water Collector (Collett et al., 1999).

Collectors of both types use flow past collecting strand or rods. Size-resolved cloud composition is generally obtained by active collectors with multiple jet/impaction surface combinations, or stages, and varying cut-point diameters. Two drop fractions can be obtained using stages of different size strands (Demoz et al., 1996) or different size jets (Collett et al., 1993; Schell et al., 1997). Collett et al. (1995) were able to collect three simultaneous fractions from one jet driven impactor, and Laj et al. (1998) and Bower et al. (2000) were able to determine six fractions by difference through parallel operation of multiple jet-driven collectors with overlapping collection efficiency curves. In 2002, Moore et al. evaluated the performance of a single cloud water collector that separated drops into five simultaneous size fractions. Testing showed that the design was reasonably successful as it provided high spatial resolution snap shots of size-resolved drop chemistry, but the collector did not collect enough water for use in place of collectors that harvest higher volumes of water.

Cloud/fog detectors

Cloud/fog detectors are an essential component of cloud/fog water sampling. A reliable indicator of cloud presence is necessary to automatically start and stop sample collection so that cloud/fog only samples, not contaminated by rain, can be collected. In the early days of cloud water sampling, relative humidity (RH) was used at most sites to estimate periods of cloud presence in lieu of an affordable direct measurement technique (Mohnen, et. al., 1990). There are numerous uncertainties however with this simple method: subjective interpretation, 5% accuracy specification of the sensor, hourly averaging, and relatively slow response time with respect to optical techniques. It was also suspected that this technique overestimated cloud frequency since near-saturation conditions can occur in the absence of clouds such as during heavy or prolonged rain events.

Backscatter reflectometers have also been used but the greater than \$10,000 cost has precluded more frequent use. Five percent of the output range of the instrument has been used as the definition of cloud presence and ensured that haze and precipitation were not mistaken for cloud impaction. One of the deficiencies of the reflectometer is that the averaging methods to obtain hourly signal values tend to overemphasize the presence of cloud within an hour if the cloud was present less than half the time.

Optical cloud detectors, such as the Mallant (Mallant, 1988) and Gerber (Gerber, 1984) use forward-scattering of cloud droplets in the open air along a diode path for measuring and translating values into grams of water per cubic meter (g/m^3) of air. Although the Gerber particulate volume monitor (PVM) requires little routine maintenance, aside from periodic calibrations, and can be deployed for extended periods of time, the high cost (approximately \$20,000) has precluded its use in some network studies or low budget investigations. While the Mallant is lower cost, it has demonstrated poor performance in measuring LWC. Several other lower cost detectors, such as the Caltech visibility sensor (Collett et al., 1990), were not evaluated for LWC measurements, and electronic components are no longer available.

Carillo et al. (2008) constructed an Optical Fog Detector (OFD) at CSU that measures light attenuation between a sending and receiving arm from which cloud/fog presence can be inferred. This instrument also requires little maintenance aside from regular calibrations and costs about \$500. The instrument was successful in reliably indicating the presence of cloud/fog in several environments, but encountered interference from rain. This enhanced response during rainy conditions can cause a false indication of fog or an overestimation of LWC. The OFD was found to be a reliable and inexpensive alternative for measuring frequency and duration of cloud/fog presence in cases of radiation fogs or non-precipitating orographic clouds.

LWC instruments

Numerous methods have been used over the years for estimation of cloud/fog LWC. In the mid to late 1980s, no field measurement technique existed in the commercial sector for cloud LWC. Most LWC measurement instruments had been designed for aircraft operation where the speed of the aircraft was an aid to the operation of the instrument. Ground-based instruments

are typically modified versions of aircraft systems and are classified according to their operating principle: inertial impactions methods, thermal, or optical (Mohnen, et. al., 1990).

Filters and impactors are the oldest and simplest method of measuring LWC (Mohnen, et. al., 1990). Filter procedures consist of drawing in large volumes of cloudy air through a tared filter for a specified period and then the filter is weighed with the accumulated water. Under light windy conditions and cloud droplets below precipitation size, this technique can come close to providing an absolute measurement of LWC. The main limitation to this method is that during periods with less than 100% humidity, evaporation can result in an underestimate of LWC. Operation is also labor intensive in that the filter must be changed and weighed hourly or after another specified resolution time. Impaction techniques are similar to filtering but rely on droplet sizing instead of mass concentration. Usually, glass slides with gelatin coating or other material sensitive to water drops are used. The slides are then analyzed with an optical microscope for determination of drop size and water content. The technique has been estimated to have approximately a 32% error rate, especially at the large or small end of the spectrum (Baumgardner, 1983).

Thermal methods consist of heated-wire instruments and can be as simple as a heated wire cooled by the evaporation of liquid water droplets (Spyer-Duran, 1968). In other versions of heated-wire systems, the instrument is operated at a constant temperature below 100 °C where the power dissipated is proportional to the square of the LWC. However, King et al. (1978) found that, at low air speeds, it was necessary to vary the aspiration speed with wind speed.

In 1978, Chylek (1978) found that infrared extinction of radiation of a wavelength of 11 micrometers should be directly proportional to LWC. However, the presence of many large droplets, greater than 28 micrometers, degrades Chylek's approximation and contributes to forward scatter errors. In 1984, Gerber proposed an instrument based on the principle that light scattered by the droplets in the near forward direction is strongly correlated with infrared extinction and is also proportional to LWC according to the Chylek relationship. Gerber's PVM measures in situ and real time the integrated volume of particles suspended in the atmosphere with a precision of 0.002 g/m³.

The MCCP used the TVA-Valente filtration instrument (Valente, et. al., 1989) for determination of LWC. This method collects droplets by filtration from a metered volume of air into a plastic cartridge filled with eight layers of a high collection efficiency polypropylene mesh. Inlet velocity was matched to the mean wind velocity to minimize non-isokinetic collection errors and a rain shield was used to minimize collection of precipitation-size droplets (Mohnen, et. al., 1990). The Gerber PVM was used for LWC measurements during MADPRO.

Future Research

While a number of important studies have been conducted, as described above, there is a current need for additional concentration and deposition estimates from cloud water and fog

exposure. Over the past two decades, interest in better understanding of atmospheric inputs of pollutants to terrestrial and aquatic ecosystems has increased substantially within the scientific community through the use of the critical load (CL) approach. Critical loads are developed using empirical as well as mass balance approaches. Both steady state models and dynamic models are used in the mass balance approach and deposition data are used in both types of models. In order to develop scientifically defensible critical loads estimates it is essential to be able to estimate the total deposition to an ecosystem. Current scientific efforts have identified occult deposition as a “need” by the NADP’s total deposition science committee (TDep) as well as NADP’s critical loads of atmospheric deposition science committee (CLAD) in developing critical loads for ecosystems that experience significant cloud and fog impaction (NADP/TDep, 2017, NADP/CLAD, 2017). Remaining knowledge gaps and suggestions for research to address them are described below.

In the near-term, an initial goal is to complete a literature review and prepare a review paper to consolidate historic research and produce standardized datasets and a data archive for cloud water sampling studies. The goal would be to verify that completed and ongoing studies are identified and data analyzed for comparability with other known studies. International studies would be included. Once complete, an analysis and cataloging of existing data could be conducted to answer needed research questions (i.e. how much are existing datasets influenced by trends in background and long-range transport signals?)

Also in the near-term, better collaboration between the cloud and fog research communities is needed. Measurements of fog water concentrations are more practical than high elevation cloud drop measurements, and much can be learned from fog studies that could potentially be applied to other, high elevation environments. For example, a TDep workgroup could be established to bring together scientists working on cloud and fog measurements. Also, a Research Gate type platform could be used to solicit participation in a social media project. To this end, a cloud deposition project could be established on Research Gate in the near future.

Finally, as much as is practicable, collect data in different environments to improve spatial variability of estimates for total Nr deposition and wet/dry/occult fractions and advocate for increased cloud and fog water measurements.

In the long-term, further work is needed with the measurement community to develop standardized and comparable sampling methods. This would continue the near-term objective of identifying and consolidating existing research. Similar to paths taken by other collaborative networks such as NADP’s AMNet, establish agreed upon standard operating procedures so that future measurements are as useful and well-documented as possible.

A second long-term goal is to evaluate the feasibility of establishing a network of sites dedicated to permanent sampling in coastal or other fog prone areas as well as a few mountain-top sites (such as in RMNP) in the western U.S. to produce more accurate deposition estimates for use in CL evaluations for sensitive high-elevation or fog-prone ecosystems. The

existing framework of current national monitoring networks is insufficient for wide-spread mountain-top sampling.

Finally, it is necessary to use available measurements to improve empirical characterization of process-level information for incorporation as CTM parameters. As the CL community increases reliance on products such as the TDep hybrid model-measurement fusion method (Schwede and Lear, 2014) or Environment and Climate Change Canada's Atmospheric Deposition Analysis Generated by optimal Interpolation from Observations (ADAGIO) fusion product (Robichaud et al., 2018), improvement of occult and fog deposition processes in CTMs is of utmost importance, which includes working with the modeling community to make quality assured measurements available for model evaluation.

References

- Acker, K.; Mertes, S.; Moller, D.; Wieprecht, W.; Auel, R.; Kalass, D. (2002) Case study of cloud physical and chemical processes in low clouds at Mt. Brocken. *Atmos. Res.* 64, 41-51.
- Aneja, V.P.; Kim, D.D. (1993) Chemical dynamics of clouds at Mt. Mitchell, North Carolina. *Air & Waste.* 43, 1074-1083.
- Baltensperger, U.; Schwikowski, M.; Jost, D.T.; Nyeki, S.; Gaggeler, H.W.; Poulida, O. (1998) Scavenging of atmospheric constituents in mixed phase clouds at the high-alpine site Jungfrauhoeh, Part I: basic concept and aerosol scavenging by clouds. *Atmos. Environ.* 32, 3975-3983.
- Baron, J.S.; Galli, L.; Wolfe, A.M.; Nydick, K.R.; Allstott, E.J.; Minear, J.T.; Moraska, B. (2000) Ecosystem responses to nitrogen deposition in the Colorado front range. *Ecosystems* 3, 352-368.
- Bator, A.; Collett Jr., J.L. (1997) Cloud chemistry varies with drop size. *J. Geophys. Res.* 102, 28701-28078.
- Baumgardner, D. (1983) An analysis of five water droplet measuring instruments. *Journal of Applied Meteorology* 22, 891-910.
- Benedict, K.B.; Lee, T.; Collett Jr., J.L. (2012) Cloud water composition over the southeastern Pacific Ocean during the VOCALS regional experiment. *Atmos. Environ.* 46, 104-114.
- Bormann, B.T.; Tarrant, M.H.; McClellan, M.H.; Savage, T. (1989) Chemistry of rainwater and cloud water at remote sites in Alaska and Oregon. *Journal of Environmental Quality* 18(2), 149-152.
- Bower, K.N.; Choularton, T.W.; Gallagher, M.W.; Beswick, K.M.; Flynn, M.J.; Allen, A.G.; Davison, B.M.; James, J.D.; Robertson, L.; Harrison, R.M.; Hewitt, C.N.; Cape, J.N.; McFadyen G.G.;

Milford, C.; Sutton, M.A.; Martinsson, B.G.; Frank, G.; Swietlicki, E.; Zhou, J.; Berg, O.H.; Mentes, B.; Papaspiropoulos, G.; Hansson, H.C.; Leck, C.; Kulmala, M.; Aalto, P.; Vakeva, M.; Berner, A.; Bizjak, M.; Fuzzi, S.; Laj, P.; Facchini, M.C.; Orsi, G.; Ricci, L.; Nielsen, M.; Allan, B.J.; Coe, H.; McFiggans, G.; Plane, J.M.C.; Collett Jr., J.L.; Moore, K.F.; Sherman, D.E. (2000) ACE-2 HILLCLOUD. An overview of the ACE-2 ground-based cloud experiment. *Tellus* 52B, 750-778.

Bowman, W.D.; Gartner, J.R.; Holland, K.; Wiedermann, M. (2006) Nitrogen critical loads for alpine vegetation and terrestrial ecosystem response: Are we there yet? *Ecological Applications* 16, 1183-1193.

Bruggemann, E.; Gnauk, T.; Mertes, S.; Acker, K; Auel, R.; Wieprecht, W. (2005) Schmucke Hill cap cloud and valley stations aerosol characterization during Febuko (I): Particulate size distribution, mass, and main components. *Atmos. Environ.* 39, 4291-4303.

Campbell, J.L.; Eager, C.; McDowell, W.H.; Hornbeck, J.W. (2000) Analysis of nitrogen dynamics in the Lye Brook Wilderness area, Vermont, USA. *Water, air and Soil Pollution* 122, 63-75.

Campbell, D.H.; Kendall, C.; Chang, C.C.Y.; Silva, S.R.; Tonnessen, K.A. (2002) Pathways for nitrate release from an alpine watershed: determination using delta N-15 and delta O-18. *Water Resources research* 38, 9.

Carillo, J.H.; Emert, S.E.; Sherman, D.E.; Herckes, P.; Collett Jr, J.L. (2008) *Atmos. Res.* 87, 259-267.

Chylek, P. (1978) Extinction and liquid water content of clouds. *J of Atmos. Sciences* 35, 296-300.

Collett, Jr., J.L.; Daube, B.; Munger, J.W. Hoffmann, M.R. (1989) Cloud water chemistry in Sequoia National Park. *Atmos. Environ.* 23, 999-1007.

Collett, Jr., J.L.; Daube Jr., B.; Hoffmann, M.R. (1990) The chemical composition of intercepted Cloudwater in the Sierra Nevada. *Atmos. Environ.* 24, 959-972.

Collett Jr, J.L.; Prevot, A.S.H.; Staehelin, J., Waldvogel, A. (1991) Physical factors influencing winter precipitation chemistry. *Environmental Science and Technology* 25, 782-789.

Collett Jr. J.L.; Oberholzer, B.; Staehelin, J. (1993) Cloud chemistry at Mount Rigi, Switzerland: Dependence on drop size and relationship to precipitation chemistry. *Atmos. Environ.* 27A, 33-42.

Collett, Jr., J.L.; Bator, A.; Rao, X.; Demoz, B. (1994) Acidity variations across the cloud drop size spectrum and their influence on rates of atmospheric sulfate production. *Geophysical Research Letters* 21, 2393-2396.

Collett, Jr., J.L.; Iovenelli, R.; Demoz, B. (1995) A three-stage cloud impactor for size-resolved measurement of cloud drop chemistry. *Atmos. Environ.* 29, 1145-1154.

Collett, Jr., J.L.; Hoag, K.J.; Sherman, D.E.; Bator, A.; Richards, L.W. (1999) Spatial and temporal variations in San Joaquin Valley fog chemistry. *Atmos. Environ.* 33, 129-140.

Collett, Jr., J.L.; Sherman, D.E.; Moore, K.F.; Hannigan, M.P.; Lee, T. (2001) Aerosol particle processing and removal by fogs: observations in chemically heterogeneous central California radiation fogs. *Water, Air, Soil Pollution: Focus* 1, 303-312.

Dawson, T. (1998) Fog in the California redwood forest: ecosystem inputs and use by plants. *Oecologia* 117(4), 476-485.

Demoz, B. B.; Collett, Jr., J.L.; Daube Jr., B. C. (1996) On the Caltech Active Strand Cloudwater collectors. *Atmos. Res.* 41, 47-62.

Devulapalli, S.S.N.; Collett, Jr., J.L. (1994) The influence of riming and frontal dynamics on winter precipitation chemistry in level terrain. *Atmos. Res.* 32, 203-213.

Dore, A.J.; Choularton, T.W.; Inglis, D.W.F. (2001) Monitoring studies of precipitation and cap cloud chemistry at Holme Moss in the Southern Pennines. *Water, Air, and Soil Pollution: Focus* 1, 381-390.

Eager, C.; Adams, M. B.; Johnson, A. H.; McLaughlin, S. B.; Cook, E. R.; De-Hayes, D. H. (1992) Ecology and Decline of Red Spruce in the Eastern United States. Springer-Verlag, New York 96, 385-411.

U.S. Environmental Protection Agency. 2016. *Clean Air Markets 2014 Progress Report*. Accessed May 10, 2017.

https://www3.epa.gov/airmarkets/progress/reports/emissions_reductions_so2.html#Fig.1.

Ewing, H.A.; Weathers, K.C.; Templer, P.H.; Dawson, T.E.; Firestone, M.K.; Elliott, A.M.; Boukili, V.K.S. (2009) Fog water and ecosystem function: Heterogeneity in a California Redwood forest. *Ecosystems* 12, 417-433.

Fenn, M.E.; Poth, M.A.; Schilling, S.L.; Grainger, D.B. (2000) Throughfall and fog deposition of nitrogen and sulfur at an N-limited and N-saturated site in the San Bernardino Mountains, southern California. *Canadian Journal of Forest Research* 30, 1476-1488.

Galloway, J.N.; Keene, W.C.; Likens, G.E. (1996) Processes controlling the composition of precipitation at a remote southern hemispheric location: Torres del Paine National Park, Chile. *J. Geophys. Res.*, 101(D3), 6883-6897.

Gerber, H. (1984) Liquid Water Content of Fogs and Hazes from Visible Light Scattering." *Journal of Climate and Applied Meteorology* 23(8): 1247-52.

Gioda, A.; Mayol-Bracero, O.L.; Reyes-Rodriguez, G.J.; Santis-Figueroa, G.; Collett Jr., J.L. (2009) Water-soluble organic and nitrogen levels in cloud and rainwater in a background marine environment under the influence of different air masses. *J of Atmos. Chemistry* 61, 85-99.

Gonzales, A.L.; Farina, J.M.; Pinto, R.; Perez, C.; Weathers, K.C.; Armesto, J.J.; Marquet, P.A. (2011) Bromeliad growth and stoichiometry: responses to atmospheric nutrient supply in fog-dependent ecosystems of the hyper-arid Atacama Desert, Chile. *Oecologia* 167, 835-845.

Guo, J.; Wang, Y.; Shen, X.; Wang, Z.; Lee, T.; Wang X.; Li, P.; Sun, M.; Collett Jr., J.L.; Wang, W.; Wang, T. (2012) Characterization of cloud water chemistry at Mount Tia, China: seasonal variation, anthropogenic impact, and cloud processing. *Atmos. Environ.* 60, 467-476.

Hedin, L.O.; Armesto, J.J.; Johnson, A.H. (1995) Patterns of nutrient loss from unpolluted, old-growth temperate forests: evaluation of biogeochemical theory. *Ecology* 76, 493-509.

Herckes, P.; Marcotte, A.R.; Wang, Y.; Collett Jr., J.L (2015) Fog Composition in the Central Valley of California over three decades. *Atmos. Research* 151, 20-30.

Hiatt, C.; Fernandez, D.; Potter, C. (2012) Measurements of fog water deposition on the California Central Coast. *Atmospheric and Climate Sciences* 2, 525-531.

Hltzenberger, R.; Berner, A.; Kromp, R.; Kasper-Giebl, A.; Limbeck, A.; Tschernwka, W.; Puxbaum, H. (2000) Black carbon and other species at a high-elevation European site (Mount Sonnblick, 3106m, Austria): concentrations and scavenging efficiencies. *Journal of Geophysical Research* 105, 637-645.

Hoag Jr., K.J.; Collett Jr., J.L.; Pandis, S.N. (1999) The influence of drop size-dependent fog chemistry on aerosol processing by San Joaquin Valley fogs. *Atmos. Environ.* 33, 4817-4832.

Isil, S., Lavery, T. F., Baumgardner, R., Mohnen, V., Miller, E., Lovett, G., et al. (2000) Mountain Acid Deposition Program (MADPro): Cloud Deposition to the Appalachian Mountains, 1994-1999. Rep. EPA/600/R-01:16.

Isil, S.; Lavery, T.F.; Gebhart, K.; Rogers, C.; Wanta, C.A. (2017) Magnitude and trends of high-elevation cloud water pollutant concentrations and modeled deposition fluxes. *Journal of Environmental Science and Engineering B* 6, 127-143.

Kasper, A.; Puxbaum, H.; Brantner, B.; Paleczek, S. (1998) Scavenging efficiency of lead and sulfate in supercooled clouds at Sonnblick, 3106 m a.s.l., Austria. *Atmos. Environ.* 32, 3967-3974.

King, M.D.; Byrne, D.M.; Herman, B.M.; Reagan, J.A. (1978) Aerosol size distributions obtained by inversion of spectral optical depth measurements. *Journal of Atmospheric Sciences* 35, 2153-2167.

Laj, P.; Fuzzi, S.; Lazzari, A.; Ricci, L.; Orsi, G.; Berner, A.; Dusek, U.; Schell, D.; Gunther, A.; Wendisch, M.; Wobrock, W.; Frank, G.; Martinsson, B.B.; Hillamo, R. (1998) The size dependent composition of fog droplets. *Contributions to Atmospheric Physics* 71, 115-130.

Likens, G.E.; Bormann, F.H.; Hedin, L.O.; Driscoll, C.T.; Eaton, J.S. (1990) Dry deposition of sulfur: a 23-year record for the Hubbard Brook Forest ecosystem. *Tellus* 42(B), 319-329.

Lindberg, S. E. (1992) Atmospheric Deposition and Canopy Interactions of Sulfur. *Atmospheric Deposition and Forest Nutrient Cycling: A Synthesis of the Integrated Forest Study*. Ecological Studies. 91: 74-89.

Lovett, G. M. (1984) Rates and Mechanisms of Cloud Water Deposition to a Subalpine Balsam Fir Forest. *Atmospheric Environment* 18(2), 361-71.

Lovett, G. M., and Reiners, W. A. (1986) Canopy Structure and Cloud Water Deposition in Subalpine Coniferous Forests. *Tellus B* 38 (5) 319-27.

Lovett, G. M., and Kinsman, J. D. (1990) Atmospheric Pollutant Deposition to High-elevation Ecosystems. *Atmospheric Environment*. Part A. General Topics. 24 (11), 2767-86.

Lovett, G.M.; Tear, T.H. (2008) Threats from Above: Air pollution impacts on ecosystems and biological diversity in the Eastern United States. *The Nature Conservancy and the Cary Institute of Ecosystem Studies*.

Mallant, R.K.A.M. (1988) Poor man's optical fog detector. *Annalen der Meteorologie*. 25, 333-334.

Menon, S.; Saxena, V.; Logie, B.D. (2000) Chemical heterogeneity across cloud droplet size spectra in continental and marine air masses. *Journal of Applied Meteorology* 39, 887-903.

Miller, E.K.; Friedland, A.J.; Arons, E.A.; Mohnen, V.A.; Battles, J.J.; Panek, J.; Kadlecek, J.; Johnson, A.H. (1993) Atmospheric deposition to a high-elevation forest at Whiteface Mountain. New York, USA. *Tellus* 45B, 209-227.

Miller, E.K.; Friedland, A.J. (1999) Local climate influences on precipitation, cloudwater, and dry deposition to an Adirondack subalpine forest: insights from observations 1986-1996. *Journal of Environmental Quality* 28 (1), 270-277.

Mohnen, V.A.; Aneja, V.; Bailey, B.; Cowling, E.; Goltz, S.M.; Healey, J.; Kadlecek, J.A.; Meagher, J.; Mueller, S.M.; Sigmon, J.T. (1990) An Assessment of Atmospheric Exposure and Deposition to High-elevation Forests in the Eastern United States. Report EPA/600/3-90/058. U.S. Environmental Protection Agency, Office of Research and Development, Washington, D.C.

Mohnen, V.A.; and Vong, R.J. (1993) A Climatology of Cloud Chemistry for the Eastern United States Derived from the Mountain Cloud Chemistry Project. *Environ. Rev.* 1 (1), 257-272.

Moore, K.F.; Sherman, E.; Reilly, J.E.; Collett Jr., J.L. (2002) Development of a multi-stage cloud water collector: 1. Design and field performance evaluation. *Atmospheric Environment* 36, 31-44.

Moore, K.F.; Sherman, E.; Reilly, J.E.; Hannigan, M.P.; Lee, T.; Collett Jr., J.L. (2004) Drop size-dependent chemical composition of cloud and fogs. Part II: Relevance to interpreting the aerosol/trace gas/fog system. *Atmospheric Environment* 38, 1403-1415.

Munger, J.W.; Collett Jr., J.L.; Daube Jr., B.C.; Hoffmann, M.R. (1989) Chemical composition of coastal stratus clouds: dependence on droplet size and distance from the coast. *Atmospheric Environment* 23, 2305-2320.

Noone, K.J.; Charlson, R.J.; Covert, D.S.; Ogren, J.A.; Heintzenberg, J. (1988) Cloud droplets: solute concentration is size-dependent. *Journal of Geophysical Research* 93, 9477-9482.

Noss, R. (2000) *The redwood forest: history, ecology, and conservation of the coast redwoods.* Washington, D.C. Island Press. 339p

Oberholzer, B.; Collett Jr., J.L.; Staaehelin, J.; Waldvogel, A. (1992) In-cloud scavenging of gases and aerosols at a mountain site in central Switzerland. *Journal of Atmospheric Chemistry* 14, 61-71.

Ogren, J.A.; Heintzenberg, J.; Zuber, A.; Noone, K.J.; Charlson, R.J. (1989) Measurements of the size-dependence of solute concentrations in cloud droplets. *Tellus* 41B 24-31.

Ogren, J.A.; Charlson, R.J. (1992) Implications for models and measurements of chemical inhomogeneities among cloud droplets. *Tellus* 44B, 208-225.

Plessow, K.; Acker, K.; Heinrichs, H.; Moller, D. (2001) Time study of trace elements and major ions during two cloud events at Mt. Brocken. *Atmospheric Environment* 35, 367-378.

Rao, X.; Collett Jr., J.L. (1995) Behavior of S(IV) and formaldehyde in a chemically heterogeneous cloud. *Environmental Science and Technology* 29, 1023-1031.

Robichaud, A.; Cole, A.; Moran, M.; Lupu, A.; Shaw, M.; Roy, G.; Beauchemin, M.; Fortin, V.; Vet, R. (2018). Total deposition measurement-model fusion in North America (ADAGIO project). ITM Air Quality, Ottawa 14-18th 2018, DOI:10.13140/RG.2.2.35589.24802.

Rueth, H.M.; Baron, J.S. (2002) Differences in Engelmann spruce forest biogeochemistry east and west of the continental divide in Colorado, USA. *Ecosystems* 5, 45-57.

Schell, D.; Maser, R.; Wobrock, W.; Jaeschke, W.; Georgii, H.w.; Kos, G.P.A.; Arends, B.G.; Beswick, K.M.; Bower, K.N.; Gallagher, M.W. (1997) A two-stage impactor for fog droplet collection: design and performance. *Atmospheric Environment* 31, 2671-2679.

Schwede, D.B. and Lear, G.G. 2014. A Novel Hybrid Approach for Estimating Total Deposition in the United States. *Atmos. Environ.*, 92, 207-220.

Spyer-Duran, P.A. (1968) Comparative measurement of cloud liquid water using heated wire and cloud replicating devices. *Atmospheric Environment* 7, 674-678.

Templer, P.H.; Weathers, K.C.; Ewing, H.A.; Dawson, T.E.; Mambelli, S.; Lindsey, A.M.; Webb, J.; Boukili, V.K.; Firestone, M.K. (2015) Fog as a source of nitrogen for redwood trees: evidence from fluxes and stable isotopes. *Journal of Ecology* 103, 1397-1407.

United Kingdom's National Meteorological Service. 2015. The Great Smog of 1952. <http://www.metoffice.gov.uk/learning/learn-about-the-weather/weather-phenomena/case-studies/great-smog>.

Valente, R.J.; Mallant, R.K.A.; McLaren, S.E.; Schemenauer, R.S. (1989) Field intercomparison of ground-based cloud physics instruments at Whitetop Mountain, Virginia. *J. Atmos. And Oceanic Tech.* 6, 396-406.

Voisin, D.; Legrand, M. (2000) Scavenging of acidic gases (HCOOH, CH₃COOH, HNO₃, HCl, and SO₂) and ammonia in mixed liquid-solid water clouds at the Puy de Dome Mountain (France). *Journal of Geophysical Research* 105, 6817-6835.

Vong, R.J.; Sigmon, J.T.; and Mueller, S.F. (1991) Cloud Water Deposition to Appalachian Forests. *Environmental Science and Technology* 25 (6), 1014-21.

Waldman, J.M. (1986) Depositional aspects of fogs and clouds. California Institute of Technology, Pasadena, CA (PhD thesis).

Wang, Y.; Xie, S.P.; Wang, B.; Xu, H. (2005) Large-scale atmospheric forcing by southeast pacific boundary layer clouds: a regional model study. *Journal of Climate* 18, 934-951.

Wang, W.X.; Xu, P.J. (2009) Research progress in precipitation chemistry in China. *Progress Chemistry* 21, 266-281.

Weathers, K.C.; Likens, G.E.; Bormann, F.H.; Bicknell, S.H.; Bormann, B.T.; Daube Jr., B.C.; Eaton, J.S.; Galloway, J.N.; Keene, W.C.; Kimball, K.D.; McDowell, W.H.; Siccama, T.G.; Tarrant, R.A. (1988) Cloudwater chemistry from ten sites in North America. *Environmental Science and Technology* 22, 1018-1026.

Weathers, K.C.; Likens, G.E. (1997) Clouds in Southern Chile: an important source of nitrogen to nitrogen-limited systems. *Environmental Science and Technology* 31, 210-213.

Weathers, K.C.; Lovett, G.M.; Likens, G.E.; Caraco, N.F.M. (2000) Cloudwater inputs of nitrogen to forest ecosystems in southern Chile: forms, fluxes and sources. *Ecosystems* 3, 590-595.

Weathers, K.C.; Collett Jr., J.L.; Garreaud, R.; Jordan, C.; Matrai, P.; O'Rourke, M.; Torregrosa, A.; Borre, L. (2014) Fog research frontiers: an interdisciplinary research agenda for coastal fog systems. White Paper.

3.1.2. Routine Monitoring

Successful regional air monitoring networks have provided consistent and standardized measurements over time. Networks in the U.S. and North America include NADP/NTN; NADP AMoN, CASTNET, IMPROVE, and CAPMoN. The measurements conducted at sites within these networks are typically low cost and high throughput to enable coordination, measurement dependability and accountability. Key issues facing the routine monitoring network are balancing costs with ensuring high quality measurements with acceptable spatial densities to address regional scale issues. Database management, and establishing, refining and adhering to proper protocols are issues that all monitoring networks are challenged with. These types of network management problems are detailed in Section **3.1.2.1 Wet deposition annual precipitation-weighted mean concentrations from incomplete time series: Influence of completeness criteria, data validation, and data substitution methods**. Remote sensing of pollutant concentrations of Nr species (Section **3.1.2.2. Satellite measurements of oxidized and reduced nitrogen for application to Nr budgets**) has exciting capabilities for unprecedented spatial resolution for deposition applications once fully developed. Satellite techniques for optical sensing can produce estimates of vertical column densities of the pollutant through the atmospheric column. These can be compared with vertical concentration profiles estimated by chemical transport models using observed surface concentrations made at monitoring network sites.

A pertinent issue associated with routine monitoring is the question of how the data will be ultimately used. Most environmental pollution studies are conducted with the over-arching goal of correcting the specified problem, but it can be difficult to relate scientific data to policy, in order to develop management solutions. This issue was referred to in Section 1 and is expanded in more detail in Section **3.1.2.3. Linking of air concentrations to deposition via transference ratios**. Section **3.1.2.4. Low-cost method for routine monitoring of air-surface exchange of Nr compounds** describes research for a low-cost sampling technique to measure time-integrated dry deposition fluxes with a method deployable at sites within a routine monitoring network.

A large stumbling block to the widespread monitoring of important compounds in the Nr deposition budget is the difficulty with which some compounds are measured. Both aerosol and gaseous organic Nr compounds are important to the overall Nr budget, yet are difficult to accurately identify and quantify because of extreme diversity in terms of speciation and in chemical properties that may cause sampling artifacts. Section **3.1.2.5. Characterization of organic nitrogen in air and precipitation** provides an overview of the state of the science in methods to characterize these compounds and identifies a key knowledge gap as a lack of standardized methods which has limited validation and comparison across studies and has precluded the analysis of organic Nr in monitoring networks.

3.1.2.1. Wet deposition annual precipitation-weighted mean concentrations from incomplete time series: Influence of completeness criteria, data validation, and data substitution methods

Bret A. Schichtel¹, Gary G. Lear², Robert S. Larson³, Mark F. Rhodes⁴, Kristi H. Morris¹, Gregory M. Beachley²

¹National Park Service, Lakewood, CO

²U.S. EPA, Office of Air Programs, Washington, DC

³Wisconsin State Laboratory of Hygiene, University of Wisconsin - Madison

⁴D&E Technical, Urbana, IL

Research topic summary

The NADP/NTN is the primary long-term monitoring network that provides precipitation depth and chemistry data for calculation of Nr deposition in the United States. Annual precipitation-weighted mean wet deposition concentrations provided by the NADP/NTN are affected by data validation protocols, methods used to account for and replace invalid wet deposition concentration measurements, and completeness criteria, which limit the use of missing data replacement.

Both the NADP data completeness criteria and the missing data imputation, i.e., replacement, protocols were generated near the beginning of the program and were primarily based on best-management practices that have not been scientifically evaluated. The monitoring network has been operating for more than 40 years and has generated an extensive dataset that now provides the opportunity to evaluate the suitability of the NADP protocols and procedures.

In this section, exploratory analyses evaluate the current completeness criteria and the sample validation procedures. These analyses show promising results that allow more sites and data to be included in annual deposition maps, thus improving accuracy and spatial representativeness of national wet deposition maps, including those generated by the NADP Total Deposition Science Committee (TDep). However, care is needed such that any relaxation of network criteria does not allow inclusion of potentially aberrant samples that can lead to increased error. Alternative data imputation methods used to calculate annual metrics were also explored. It was shown that accounting for the dependence of wet deposition concentrations on season and precipitation totals could reduce errors in the estimated concentrations relative to the current NADP approach and provides a basis to develop improved data replacement methods.

Research needs for criteria adjustment and alternative data imputation methods can largely be met in the near term based on existing data and sampling locations. These include

- evaluation of the definition of contaminated samples (i.e., samples that need to be excluded),
- assessment of errors in the data flagged as left in the field for extended sampling durations and those that were exposed to dry deposition,
- identification of samples with potential systematic biases that meet current criteria but should be invalidated,
- evaluation of differences and types of sample invalidation for specific methods (e.g., wet-only collectors: Aerochem versus N-CON collectors),
- development and evaluation of data imputation methods that properly account for concentration seasonal and precipitation dependencies across space and time and that can be applied across the NADP/NTN network,
- assessment of errors in annual wet deposition metrics due to missing data,
- evaluation of alternative methods for precipitation weighting for annual mean concentrations, including using substitute precipitation data from nearby gauges and accounting for variations over time.

The best solution to reduce errors in aggregated wet deposition data is to reduce the number of invalid samples. This can be accomplished by improving the sampling techniques and developing strategies to improve data collection efficiency and quality. While no detailed discussion is provided, several new sampling techniques and strategies were identified to adapt or augment current methods to make the data records more complete. Examples of longer-term research needs include

- backup samplers to reduce incomplete sampling intervals (e.g., backup bulk snow collectors),
- collection of more-representative samples using augmented methods (e.g., windshields, bird-proofing, debris exclusion, operator training, real-time monitoring),
- comparison of reliability and functionality of optical precipitation sensors that can operate in remote areas on battery or solar power to improve precipitation collection,
- evaluation of special protocols for monitoring extreme events and adverse weather conditions, especially for high-altitude and coastal sites.

Collocation studies will need to be conducted to ensure that these changes do not artificially bias the sampling record. In cases where an artifact is eliminated, protocols for treating archived data will be required.

Introduction

The NADP/NTN monitoring network (<https://nadp.slh.wisc.edu/>, accessed April, 2019) collects and analyzes weekly wet deposition samples at approximately 270 monitoring sites located throughout the United States. At each NTN monitoring site, precipitation samples are collected for analysis and an automated precipitation gauge records precipitation depth. The precipitation gauges are highly reliable and generally have data recoveries in excess of 90%. The precipitation samples are collected in buckets that are open during precipitation events and closed otherwise. These samples are prone to contamination by windblown debris and require site operators to collect them every week. Wet deposition monitoring in remote high-elevation monitoring sites is particularly challenging due to extreme weather conditions such as high winds, blowing and drifting snow, and subfreezing temperatures. These conditions are very demanding and can cause monitoring equipment failures and prevent operators from reaching the sites within the required time frame. For example, snow and ice can bury equipment (i.e., solar panels, gauges, and collectors), freeze batteries, and jam collector lids and motors. Disabled equipment in remote locations can take weeks to repair, resulting in missed or invalid data, with collectors left open for extended periods of dry exposure. Adverse conditions also make site access dangerous or impossible, resulting in extended sampling periods.

The NADP employs rigorous quality assurance (QA) protocols (NADP, 2016a; NADP, 2016b) to ensure accurate data and to invalidate potentially compromised data. These protocols include proper instrument operation during sampling, proper sample handling in the field and laboratory, and limiting the sample collection duration. They also include screening processes during the laboratory analysis (e.g., inspecting samples for any evidence of visible contaminants or sample leakage) and post-analysis data comparison (e.g., comparing data against historical concentrations for the site) to identify potentially contaminated samples. Sample validation criteria are available from the NADP web site:

<http://nadp.slh.wisc.edu/data/ntn/meta/ntnDataValidation.pdf> and
<http://nadp.slh.wisc.edu/data/ntn/meta/ntn-weekly-meta.pdf>.

The QA procedures can result in significant fractions of the samples being invalidated for any given site and year (site-year). When calculating annual metrics, e.g., annual precipitation-weighted mean concentrations, the NADP recommends a set of completeness criteria to minimize potential errors and biases. Three completeness criteria are defined for the network as a whole and form the basis for the decision to include a site in NADP products such as annual isopleth maps and seasonal data summary tables

(<http://nadp.slh.wisc.edu/data/ntn/meta/ntnDataValidation.pdf>, accessed January 29, 2019):

- Criterion 1. There must be valid samples (as defined above) for at least 75% of the summary period.
- Criterion 2. There must be precipitation amounts (including zero amounts) either from the rain gauge or from the sample volume for at least 90% of the summary period.

- Criterion 3. There must be valid samples (as defined above) for at least 75% of the total precipitation amount reported for the summary period.

These criteria have been relaxed in various assessments. For example, in the Rocky Mountain National Park (RMNP) Nitrogen Deposition Reduction Plan (NDRP) (CDPHE, 2007), the annual precipitation-weighted mean deposition rates of inorganic nitrogen measured at Loch Vale, Colorado, were used to track progress toward the reduction of excess reactive nitrogen deposition to below the critical load in RMNP. In that work, Criteria 1 and 2 were dropped from consideration. In the national wet deposition trend analysis by Lehman et al. (2005), levels in Criteria 1, 2, and 3 were reduced to 50%, 75%, and 50%, respectively. In both cases the criteria were relaxed to increase the number of annual averages used in the analyses. The increase in error due to the relaxed criteria was not assessed.

The NADP default approach for calculating annual precipitation-weighted mean concentrations (C_{AWM}) is

$$C_{AWM} = \left(\frac{\sum_{i=1}^m C_i P_i}{\sum_{i=1}^m P_i} \right) \quad (1)$$

where m is the number of valid weekly values for the year, C_i is the weekly concentration of a given ion in milligrams per liter, and P_i is the weekly precipitation depth in centimeters (cm), as measured by the precipitation gauge. Annual deposition (D_{Annual}) is calculated by multiplying C_{AWM} by the total annual precipitation depth as

$$D_{Annual} \text{ (kilograms hectare}^{-1} \text{ year}^{-1}) = (C_{AWM} P_A) \times 0.10 \quad (2)$$

where P_A is the annual total precipitation depth measured by the precipitation gauge or estimated by sample depth (cm) when the precipitation gauge measurement is missing. The value 0.10 is a unit conversion factor. The logical implication of this method for precipitation weighting and subsequent calculation of annual deposition is that every week with missing chemistry data is replaced with the C_{AWM} . This procedure does not account for seasonal variations in the concentrations of the wet deposition sample nor the inverse relationship between concentration and precipitation depths. This can lead to increased errors and potential biases in annual metrics when a significant fraction of the measured precipitation has invalid chemistry data and the invalid samples have seasonal and precipitation dependencies. Ensuring the data meet the completeness criteria reduces these errors, and when they are not met, the C_{AWM} and D_{Annual} for those sites are not included in the calculation of the NADP annual wet deposition raster data, which are used in the NADP TDep workgroup products and various analyses. This results in a loss of about 23% of the NADP/NTN site-years from 1978 to 2017, hindering the generation and examination of spatial patterns in annual deposition rates and long-term trends. The failure rate is relatively constant over the decades, with about 21% of the NADP/NTN site-years failing to meet the criteria in the last 10 years. This issue is particularly acute at remote high-alpine sites, which present challenging environments for both the sampling equipment and operators. Since 1978, more than 40% of the site-years for NADP/NTN sites with elevations above 1500 meters have invalid annual metrics.

The NADP completeness criteria and data imputation, (replacement) method were generated near the beginning of the program and are primarily based on best-management practices that have not been critically evaluated. The monitoring network has been operating for more than 40 years and has generated an extensive dataset that provides the opportunity to evaluate the appropriateness of the NADP protocols and procedures. In this work, exploratory analyses evaluate the completeness criteria, sample validation procedures, and alternative data imputation methods for replacing invalid chemistry data when calculating annual metrics. If the completeness criteria could be relaxed, the sample validation procedures relaxed, or the data imputation methods improved to reduce the error and bias in annual metrics, then more sites could be included in the C_{AWM} and D_{Annual} datasets. This would improve the accuracy of the TDep maps and other data products. The scope of this analysis is for reactive nitrogen (Nr) species, including NH_4^+ and NO_3^- , although results are likely to be similar for SO_4^{2-} .

State of the science

NADP/NTN data validation and censoring criteria

The NADP/NTN data are subject to rigorous data validation procedures to ensure proper equipment, sampling, operator, and laboratory protocols are followed. Any sample that fails any criteria is flagged as invalid. The flagging is done using a series of “Valcodes” and “Invalcodes”. Valcodes are assigned to all samples that are considered valid and are

- 0 - invalid sample,
- t - valid trace sample,
- d - valid dry collection period,
- w - valid wet sample of sufficient volume for complete analysis,
- wa/wd - valid wet sample, diluted for analysis, and
- wi – valid wet sample of insufficient volume for complete analysis (without dilution).

Only samples with valcodes of w, wa, wd, and wi are used by the NADP/NTN in calculating weighted mean concentrations and deposition values. Invalcodes are explanatory codes assigned to invalid samples and are

- b - bulk sample (collector was open continuously throughout sampling period.),
- u - undefined sample (collector was open for more than 6 hours but less than the entire sampling period when no precipitation was occurring.),
- f - field protocol departure,
- c - contaminated sample,
- v - insufficient volume for analysis,
- e - extended sampling interval (>194 hours, i.e., 8 days and 2 hours),
- l - lab error,
- i - incomplete chemical analyses, applicable for data prior to 2015,
- n - no sample collected,
- p - precipitation amount unknown, and
- x - reasons other than described above.

Many NADP data-validation and censoring criteria were derived from best-management principles without experimental evidence or support. The NADP continues to evaluate the representativeness of valid and invalid data alike. The following analysis compares the distribution of the invalidated NH_4^+ and NO_3^- concentrations for each invalid code to the distribution of valid concentrations using all measured data from 2000 through 2016. This was accomplished by first calculating C_{AWM} using only valid concentrations for each site-year. The relative difference from the C_{AWM} for each weekly concentration was calculated as

$$relative\ difference_j = \frac{(C_{weekly}^{i,j} - C_{AWM}^i)}{C_{AWM}^i} \quad (3)$$

where i represents a given site-year and j represents the invalid code. $C_{weekly}^{i,j}$ is one of the weekly values in site-year i and invalid code j . The relative differences were grouped by their flags, with all valid samples in one group and the invalid samples grouped by their invalcode. The average (ARD) and standard deviation of the relative differences and the median of the absolute relative differences (MAD) were calculated for each group over the 2000–2016 time period (Table 1). The ARD is a measure of the average difference from the annual mean, and standard deviation and MAD are measures of the spread of the distribution of these differences. The standard deviation is sensitive to outliers while the MAD is less so.

As shown, on average the valid weekly samples have concentrations greater than the C_{AWM} for both NO_3^- and NH_4^+ . This is expected since C_{AWM} is more heavily weighted by high precipitation depths, which tend to have lower concentrations (Figure 3). The samples flagged as extended duration (e) and undefined (u) have similar ARDs and standard deviations to the valid data. This suggests that NH_4^+ and NO_3^- concentrations in samples left in the field for more than 8 days (“e” invalid code) or had more than 6 hours of dry deposition exposure (“u” invalid code) are not biased relative to the valid samples and may indeed be considered valid samples in revised sample validation protocols. On the other hand, contaminated samples (“c” invalid code) are clearly biased high relative to valid samples. All other flagged samples show deviations in their distributions relative to the valid samples. The bulk-collected samples (“b” invalid code) have a high ARD and standard deviation relative to valid samples. These invalid samples collect dry deposition, and the results indicate that they are biased high relative to the valid samples, as expected. However, the MAD is similar to that for valid samples. This indicates that the dry deposition contribution to the sample, as well as any losses, e.g., sample evaporation, relative to the wet deposition is small for a significant fraction of these samples and could potentially be included in C_{AWM} .

To test the effect that the excluded e- and u-coded samples have on the C_{AWM} , these averages were recalculated to include the e and u codes with the valid samples and were regressed against the valid-only C_{AWM} (Figure 1). The regression results have a slope near 1, indicating that the addition of the e- and u-coded samples does not affect C_{AWM} on average. However,

shifts in the C_{AWM} for a specific site-year are evident by the scatter around the one to one line, and in some cases the change can be large.

The similarity of the distributions in the ammonium and nitrate concentrations for samples flagged as extended and undefined and a subset of bulk samples to valid samples suggest that many of these samples are indeed valid or have small biases. Additional analyses of collocated data in conjunction with field and laboratory studies could be conducted to better understand the potential increased errors and biases in these samples compared to valid samples. This could lead to changes in the sample censoring protocols and increase the number of valid samples and site-years that meet the data completeness criteria.

Table 1. Average and standard deviation of the relative difference (RD) and median absolute relative difference (MAD) for comparison of the distributions of valid and invalid wet deposition ammonium (NH₄⁺) and nitrate (NO₃⁻) concentrations for all NTN sites, 2000–2016.

[Shading denotes invalid coded samples with similar distributions to valid samples]

NADP Invalcode and definition	Count	Percent	ARD		RD Standard Deviation		MAD	
			NH ₄ ⁺	NO ₃ ⁻	NH ₄ ⁺	NO ₃ ⁻	NH ₄ ⁺	NO ₃ ⁻
All valid samples	186,039	84.9	0.39	0.47	1.8	1.5	0.54	0.46
b - bulk samples (collector always open)	993	0.5	12	1.2	340	3.5	0.59	0.55
c - contaminated samples	16,666	7.6	8.7	2.5	73	4.1	2.3	1.7
e - extended sampling interval (>8 days)	1,893	0.9	0.19	0.32	1.5	1.4	0.55	0.46
u - undefined samples (open collector >6 hrs and <sampling interval with no precip.)	3,623	1.7	0.40	0.57	2.4	2.7	0.57	0.47
f - field protocol departure	448	0.2	0.84	2.2	2.4	18	0.66	0.58
i - incomplete chemical analyses	5	0.0	0.62	1.7	1.6	12	0.89	2.1
l - lab error	61	0.0	1.7	1.2	5.5	33	0.72	0.48
x - reasons other than described above	2	0.0	-	-	-	-	-	-
n - no sample collected	570	0.3	-	-	-	-	-	-
v - inadequate volume for analysis	8,727	4.0	-	-	-	-	-	-

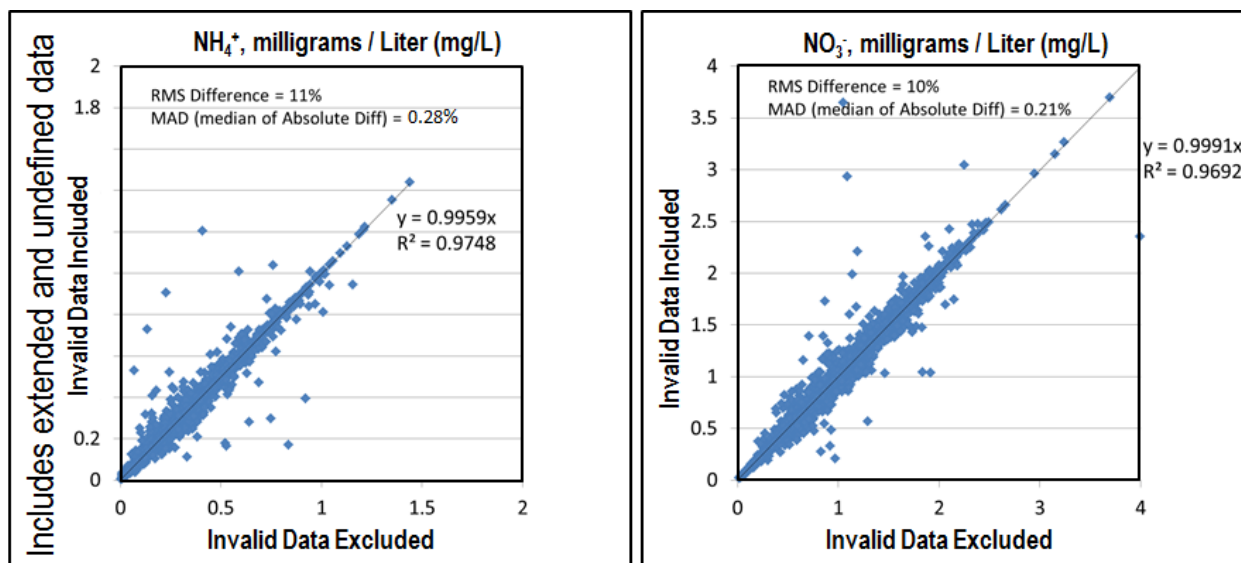

Data from Bob Larson, NADP Program Office, April 2017

Figure 1. Comparison of annual precipitation-weighted mean concentrations calculated using the standard NADP method and the inclusion of the invalid extended duration and undefined samples from 2000 to 2016.

NADP/NTN protocols for missing data and dependence of concentrations with precipitation depth

The NADP protocol for calculating D_{Annual} from the wet deposition time series with invalid chemistry data has been to replace the invalid concentrations with C_{AWM} values. This protocol is based on the assumption that the actual concentrations for the invalid samples have, on average, the same distribution as the valid concentrations. The actual concentrations of these invalid samples are unknown, which precludes a direct assessment of this assumption. However, it is known that the concentrations of the wet deposition samples are generally seasonal (Pratt and Krupa, 1983). The seasonality varies with location, but as illustrated in Figure 2, wet-deposited nitrate and ammonium at Loch Vale, Colorado, have a strong seasonality, with summer concentrations a factor of 2 and 4, respectively, higher than winter. Using C_{AWM} to substitute for invalid samples will tend to overestimate winter concentrations and underestimate summer concentrations. Wetherbee and Mast (2016) showed that seasonal cycle is not necessarily fixed and shifts with changes in the snow season.

The wet deposition concentrations are also inversely dependent on precipitation depth. This is shown in the scatter plot in Figure 3 where all weekly nitrate concentrations measured from 2000 through 2015 are compared to the weekly precipitation depth. Average concentrations vary widely across the network (Lehmann et al., 2005). Therefore, each concentration was normalized by the C_{AWM} for a give site and year. A 31-point smoothing was applied to the data to better show the average relationship between the concentrations and precipitation totals. As shown, there is an exponential decline in nitrate concentrations with increased precipitation depth. At low precipitation, the normalized concentrations are more than 3 on average, which

reduced to about 0.5 at 100 mm of precipitation. The decrease in concentration is expected due to the limited mass in the atmosphere, and as it is washed out, the increased precipitation dilutes the concentrations collected in the sampler (Barrie, 1981; Collett et al., 1991; Schichtel and Husar, 1997). Similar relationships occur for all measured species but vary based on the efficiency with which the individual species are washed out (Barrie, 1985; Kasper-Giebl et al., 1999; Andronache, 2004). The NADP protocol uses the normalized value of 1 (demarcated with a solid line in Figure 3) to substitute for all invalid concentrations, which clearly underestimates concentrations at low precipitation and overestimates them at high precipitation depths.

Systematic biases in C_{AWM} and D_{Annual} for a given site would occur if there are collinearities in the invalid samples with season and precipitation. As shown in Figure 4, from 1983 through 2015, non-dry valid and invalid samples have different seasonal and precipitation dependencies across the NTN network. Non-dry samples are those with sufficient precipitation amounts to be analyzed for ionic composition. This change in dependence varies by site. At Loch Vale (Figure 4), invalid samples tend to have a higher frequency of precipitation totals <10 mm and >50 mm. In addition, about 35% of the invalid samples occur in the winter months and only 19% in the fall months, compared to about 25% for all non-dry samples in all seasons, and there are no invalid summer samples with precipitation totals >50 mm. Samples with high precipitation totals have a large influence on C_{AWM} and D_{Annual} . The shift in seasonality and occurrence of invalid samples compared to valid samples at Loch Vale on these high-precipitation weeks could introduce significant biases into C_{AWM} and D_{Annual} .

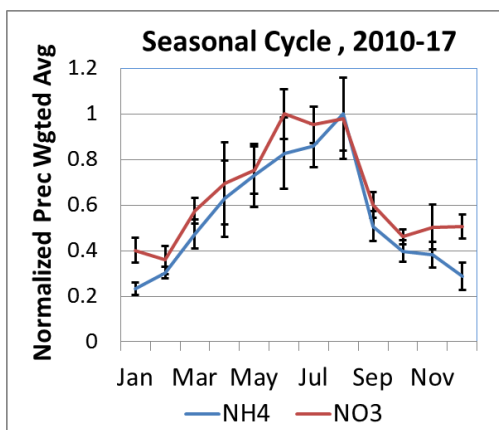

Figure 2. Average precipitation-weighted monthly ammonium (NH₄) and nitrate (NO₃) concentrations, normalized by the maximum monthly value. Data only include valid weekly concentrations measured at Loch Vale from 2010 to 2017. The error bars are the standard error of the average.

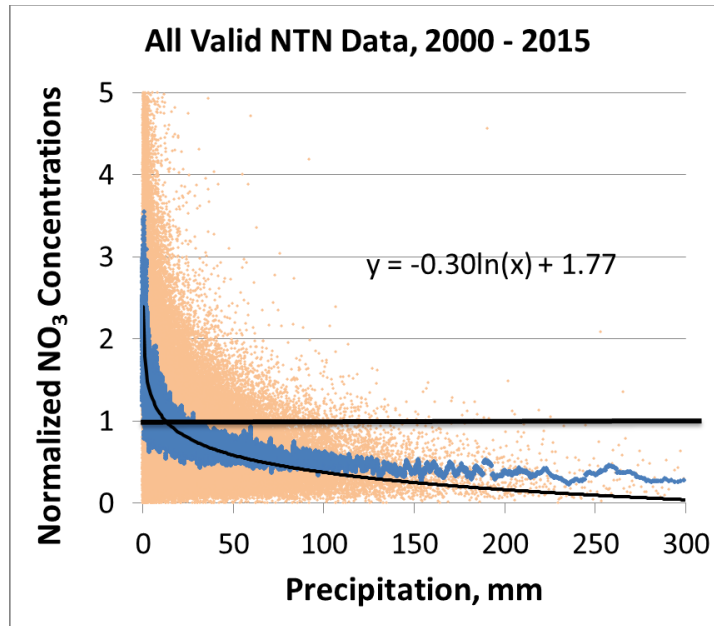
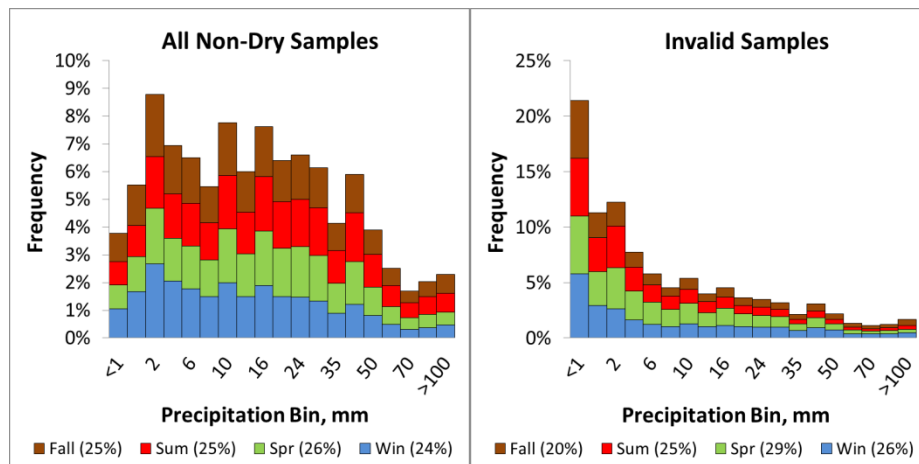

Figure 3. Normalized valid weekly nitrate concentrations (orange diamonds) for all NTN sites for 2000-2015 compared to precipitation depths modeled with a logarithmic best fit line (black line and equation). The blue squares are a 31-point running concentration average with the data sorted by their precipitation depth. The black reference line at the concentration 1 is the normalized precipitation-weighted average currently used by the NADP to substitute for missing values.



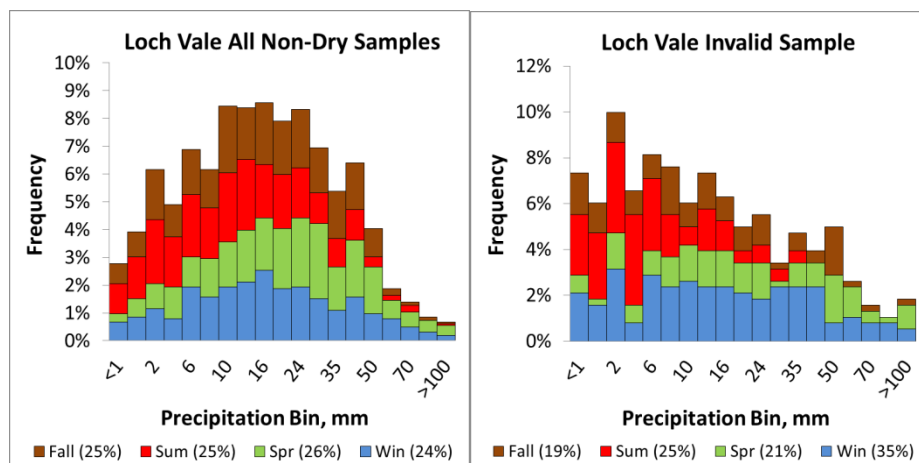

Figure 4. Histograms for the occurrence of wet deposition samples as a function of season and precipitation depth for all non-dry samples and all invalid samples collected from 1983 to 2015. The top row is for all NTN sites while the bottom row is for Loch Vale, CO.

Alternative data imputation methods for samples with invalid chemistry

The NADP default protocol for calculating C_{AWM} and D_{Annual} is to replace missing wet deposition sample concentrations with the C_{AWM} calculated from valid samples (equation 1). This does not account for any dependencies of the concentrations on season (Figure 2) and precipitation depth (Figure 3), which can introduce systematic biases in C_{AWM} and D_{Annual} when the occurrence of invalid samples has seasonal and precipitation dependencies (Figure 4). These errors and biases could be reduced by using data imputation methods that account for these dependencies.

As shown in Figure 3, the concentration dependence on precipitation depth is modeled reasonably well by a best-fit logarithmic relationship with a correlation of 0.47 against the weekly concentrations. The correlation of 0.91 against the smoothed values illustrates that a log model reproduces the average concentration dependency on precipitation well, the point of this exercise, though there is significant scatter around the average. Similar results were found for ammonium, but the correlations were somewhat lower due to increased variance in the ammonium concentrations. As shown, the concentrations at the highest precipitation depths (>100 mm) tend to be underestimated. Other relationships, such as an exponential function, may fit the data better but are not explored here. However, this is an improvement over the current C_{AWM} , which is equivalent to the line of $y = 1$ in Figure 3 and has a correlation of 0.

Building on this relationship, two alternative empirical data imputation methods were explored and tested on the ammonium and nitrate measured at all sites in the NTN network from 1990 through 2016. In the first data imputation method, best-fit logarithmic relationships were derived for each site-year and species and thus only account for the concentration dependency on precipitation depth. In the second method, all data were first normalized by the C_{AWM} , as was done in Figure 3, and grouped together by season, and then best-fit logarithmic relationships were derived for each season and species. The seasons were defined as three

month periods with the winter season comprised of December, January, and February, and the subsequent seasons following this pattern.

The first method accounts for changes in average concentrations and the concentration–precipitation relationship by location and year. However, one year of data is a limited dataset, and the regression results will be sensitive to outlier data points. In addition, it does not account for seasonal variations in concentrations. In the second method, the grouping of data across all sites has the advantage that the regression analyses are conducted on a large dataset, resulting in stable regressions. In addition, it accounts for the average seasonal variation in concentrations across the network, though the seasonality does vary by location. Last, using normalized values in the seasonal regression equations makes them applicable to other locations and at sites with trends in the wet deposition concentrations.

This approach assumes that the concentration–precipitation relationships are statistically similar across the United States. Implicit in this assumption is that the wet deposition rates are similar with space and time. However, wet deposition washout ratios are known to vary in space and time, being dependent on precipitation chemistry (Barrie, 1981, 1985; Schichtel and Husar, 1997); meteorological conditions including solid (e.g., snow) versus liquid precipitation (Raynor and Hayes, 1982; Lynch et al., 1989); and the microphysical properties of the clouds and atmospheric transport during the precipitation event (Collett et al., 1991). The NTN network collects week-long integrated samples, and the relationships depend on the average frequency and rates of the precipitation events that occur over the week, which will vary by space and time. On the other hand, wet removal of particles and soluble species, such as ammonia and nitric acid, is efficient, and most of these constituents are quickly washed out from the atmosphere in a precipitation event (Barrie, 1985; Kasper-Giebl et al., 1999; Andronache, 2004). Therefore, the dependence on wet removal processes is most important at low precipitation depths, which have a smaller influence on C_{AWM} values.

These two alternative data imputation methods allow for the evaluation of the different roles of the precipitation and seasonal dependencies. These methods were evaluated by using them to simulate the ammonium and nitrate concentrations measured at all NTN sites from 2000 through 2015. The differences between the estimated and measured concentrations at each site were then aggregated to estimate the average difference, i.e., bias and root mean square error (RMSE), and these statistics were compared to the same statistic derived from the NADP default approach.

The results are presented in Figure 5 as bar charts, where the bars are the average results across all sites and the error bars are the standard deviation. As shown, on average, the NADP approach underestimated the measured concentrations for all seasons and by an average of almost 50% on an annual basis. This underestimation should be uninfluenced by the concentration seasonality; therefore the bias is a result of the precipitation dependence and the fact that the C_{AWM} is more heavily influenced by high-precipitation events, which tend to have lower concentrations than low-precipitation events. The simulation of weekly

concentrations using the log regression fit by site-year (red bars) has no bias on an annual basis, as expected, but has seasonal biases with overestimations during the winter and fall, balanced by underestimations in the spring and summer months. When the seasonality in the concentrations is accounted for in the regression analysis (green bars), the seasonal bias is removed. However, the variance in the bias across the sites is increased compared to the site-specific regression fits. This is an indication that results could be improved if the spatially dependent concentrations-to-precipitation relationship is used as opposed to a single relationship. As shown, the errors for the log regression fit by site-year and by season were also slightly smaller than for the NADP approach. However, all methods have annual errors more than 100% on average when simulating the concentrations.

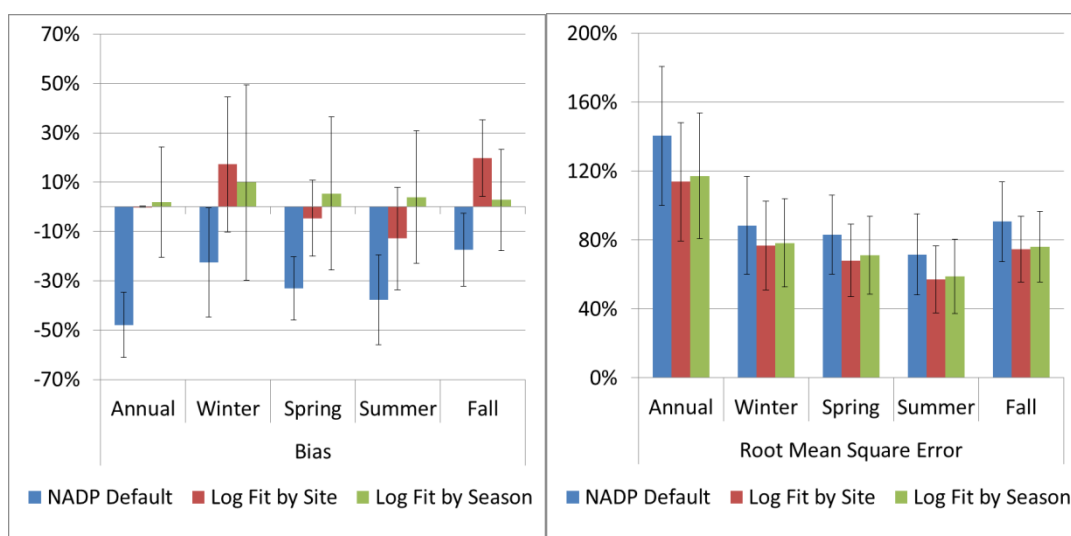

Figure 5. Relative bias (left) and error (right) in the simulation of the 2000–2015 weekly nitrate concentrations at each NTN site using the three data imputation methods. The default NADP method is in blue, and the best-fit log regressions for each site and season are in red and green, respectively. Bias is the average of the relative differences between the estimated and measured concentrations, while the error is the relative root mean square of the differences, calculated for each site then averaged together. Error bars are the standard deviations in the bias and error across all sites.

These results show that on average the NADP approach of replacing missing chemistry data with C_{AWM} underestimates concentrations at low precipitation rates and overestimates them at high precipitation rates. Due to the more frequent occurrence of lower precipitation totals, C_{AWM} has a large average underestimation, ~50%, of the weekly concentration data. Accounting for the concentration dependence on precipitation and its variability in space removes the annual bias, but compensating biases by season still exist. The seasonal bias can be removed by accounting for the seasonal differences in the concentrations, and a data imputation method that properly accounts for both the precipitation and seasonal dependencies as well as their variability in space is needed.

The alternative data imputation methods reduced the average error in the simulation of the weekly concentration values, though the reductions were small and the errors remained large, ~100%. While the alternative approaches may be able to produce less-biased annual averages than the current NADP approach, average values cannot reproduce the variability in the weekly measurements. The best solution to reduce the errors in aggregated wet deposition data is to reduce the number of invalid samples. Efforts are needed to modify the sampling equipment and procedures and further investigate the data censoring methods to increase the number of valid samples, particularly at the high-elevation sites. Several methods for accomplishing this are provided in the in the section on future research.

Annual precipitation-weighted mean concentration data completeness criteria

The NADP data completeness criteria for calculation of C_{AWM} and D_{Annual} are used with the intention to minimize any biases due to missing data and enhance the representativeness of NADP data. These criteria were evaluated for their appropriateness as determining factors for inclusion of individual site records in annual mapping products. A jackknife analysis was done using weekly NTN samples from complete annual records with >98% completeness (Hollander and Wolfe, 1999). The dataset included 293 complete annual site records used as the “true” annual time series and the corresponding C_{AWM} . From these sets, 619 simulated templates were created by randomly removing data as “missing records” for these datasets. These template datasets were then binned by their attainment of Criteria 1, 2, and 3. Relative percent differences (RPD) were calculated between the C_{AWM} from the complete dataset and the C_{AWM} from the simulated “missing record” template. Records for high-altitude sites in California, Colorado, Oregon, Washington, and Wyoming were included and evaluated independently. Results of the jackknife analysis are shown in Figures 6–9 as the distributions of the individual RPDs plotted as boxplots and are an assessment of the errors in the C_{AWM} resulting from the missing data in each template comparison. This analysis did not account for any seasonal or precipitation dependencies in the invalid samples discussed in the previous sections. Therefore, the results are a lower bound in the C_{AWM} errors as a function of completeness criteria censoring. The acceptable error bound was defined as the interquartile ranges of the RPD values being within $\pm 10\%$. This is based on the desired limit in the C_{AWM} errors for annual NADP mapping products. The scope of this analysis is limited to reactive nitrogen (Nr) species and should be expanded to include the other analytes.

Boxplots in Figure 6 indicate that the interquartile ranges of annual concentration minus template concentration differences for NO_3^- are all within $\pm 10\%$ when at least 65% of the summary period is represented by valid samples, whereas Criterion 1 prescribes 75% representation by valid samples. This indicates that Criterion 1 could be relaxed to 65% without a significant change in error of estimating annual precipitation-weighted mean concentrations. This could allow more sites to be included in annual deposition mapping products.

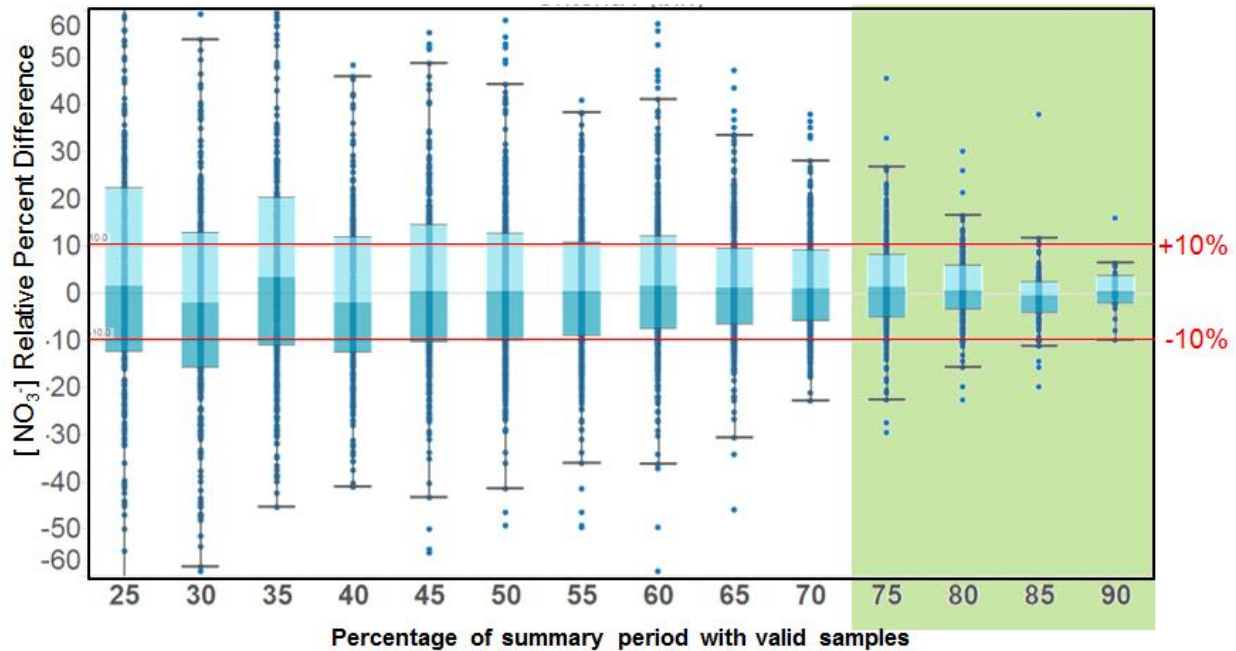

Figure 6. Complete-minus-template relative percent differences for annual nitrate concentrations over a range of percentages of annual summary periods with valid samples. Shaded region is in compliance with Criterion 1, with at least 75% valid samples for the summary period (1 year).

Boxplots in Figure 7 indicate that the interquartile ranges of annual-precipitation-depth minus template-precipitation-depth RPD values fall outside -10% at approximately 90% of the summary period being represented by valid precipitation-depth data, which is consistent with the Criterion 2 protocol. Boxplots in Figure 8 indicate that the interquartile ranges of annual-concentration minus template-concentration RPD values for NO₃⁻ fall outside +10% at approximately 80% of the summary period being represented by valid precipitation-depth data. Therefore, the jackknife analysis confirms that Criterion 2 is appropriate for limiting errors in the annual deposition mapping products for NO₃⁻.

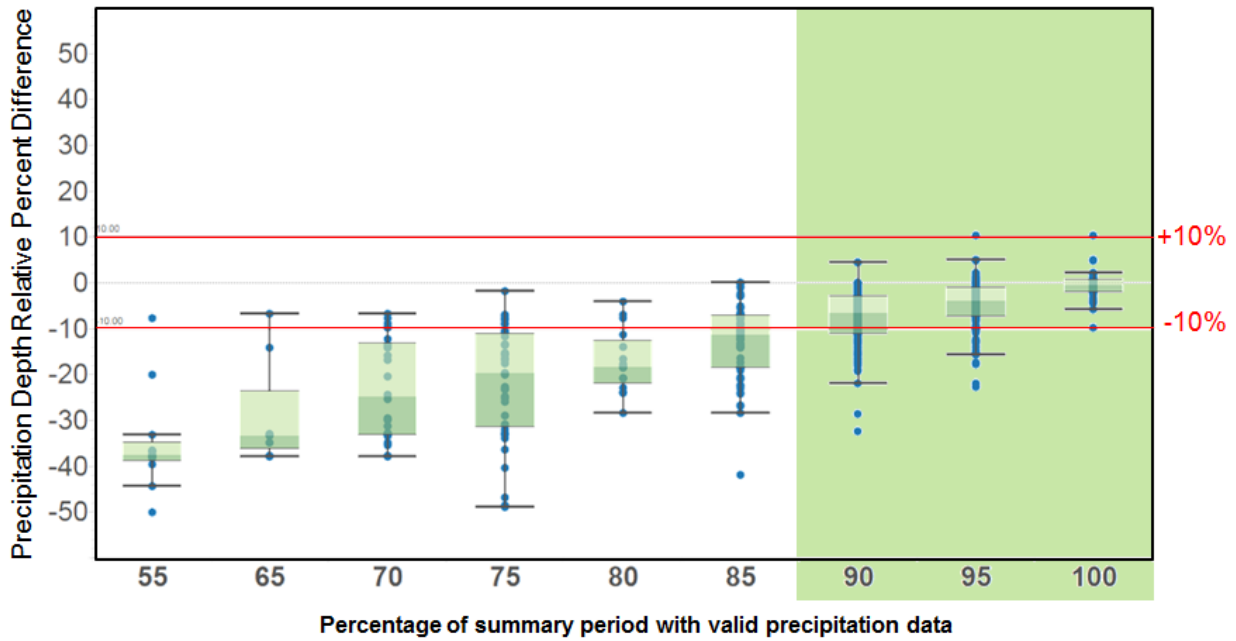

Figure 7. Complete-minus-template relative percent differences for annual precipitation-depth over a range of percentages of annual summary periods with valid precipitation-depth data. Shaded region is in compliance with Criterion 2, with at least 90% of the summary period having valid precipitation-depth data.

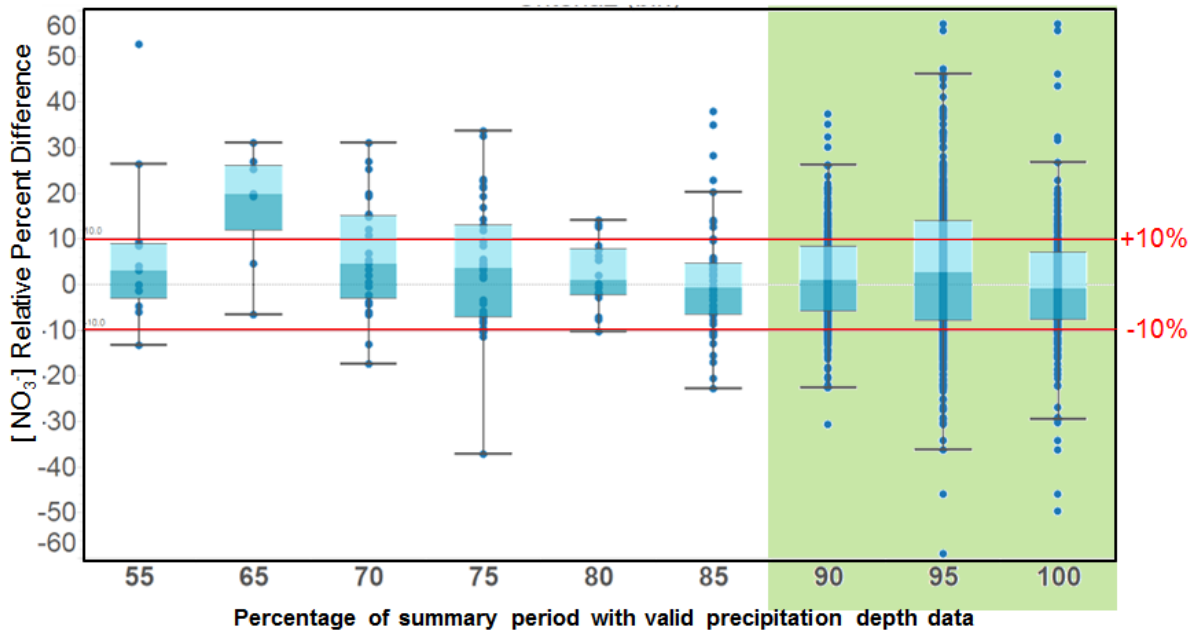

Figure 8. Complete-minus-template relative percent differences for annual nitrate concentrations over a range of percentages of annual summary periods with valid

precipitation-depth data. Shaded region is in compliance with Criterion 2, with at least 90% of the summary period having valid precipitation-depth data.

Provided that Criteria 1 and 2 are satisfied, there must also be 75% of the annual precipitation depth represented by valid samples per Criterion 3. Boxplots in Figure 9 indicate that the interquartile range of annual-concentration minus template-concentration RPD values for NO_3^- falls outside the +10% limit when approximately 60% of the precipitation depth is represented by valid samples. This suggests that Criterion 3 could be relaxed to 65% of the precipitation depth represented by valid samples to include more sites in the interpolated annual mean concentration and deposition raster data without any appreciable increase in uncertainty. However, it might be more defensible to set Criterion 3 to 70%, because the 75th percentile of the differences coincides with +10% RPD values when only 65% of the precipitation depth is represented by valid samples (Figure 9). Making Criterion 3 less stringent (e.g., 70%) would allow more sites to be represented in the annual deposition mapping products.

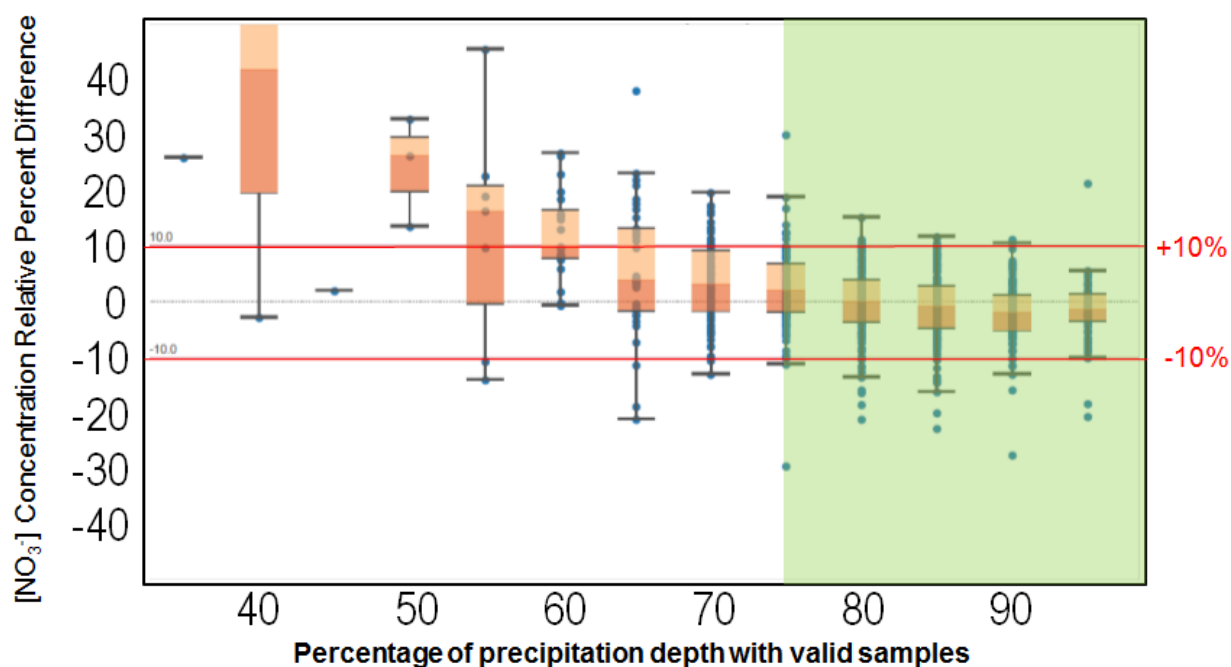

Figure 9. Complete-minus-template relative percent differences for annual nitrate concentrations over a range of percentages of annual precipitation depth with valid samples. Shaded region is in compliance with Criterion 3, with at least 75% of the annual precipitation depth represented by valid samples.

Another jackknife analysis was performed to determine the effect of censoring annual wet deposition monitoring records due to nonattainment of data completeness criteria. This addresses the question, “what effect will the inclusion of more sites (i.e., the desired effect from relaxing the completion criteria described above) have on the spatial interpolation of the

mapping products?” The analysis described here is for NH_4^+ but should be conducted for all species considered. For this analysis, sites were removed one at a time with no replacement from the inverse distance-weighted (IDW) spatial interpolation of annual precipitation-weighted mean concentrations. Site-specific median absolute percent differences (MAPD) were calculated for the differences between the base interpolation and the interpolation with the sites removed. The analysis was repeated using the IDW raised to powers of 1.5, 2.0, 2.5, and 3.0 and using a range of maximum distances between points, including 300, 400, and 500 kilometers. Finally, the effect of applying all NADP completeness criteria to censor the dataset as opposed to no application of NADP completeness criteria was evaluated (Figure 10).

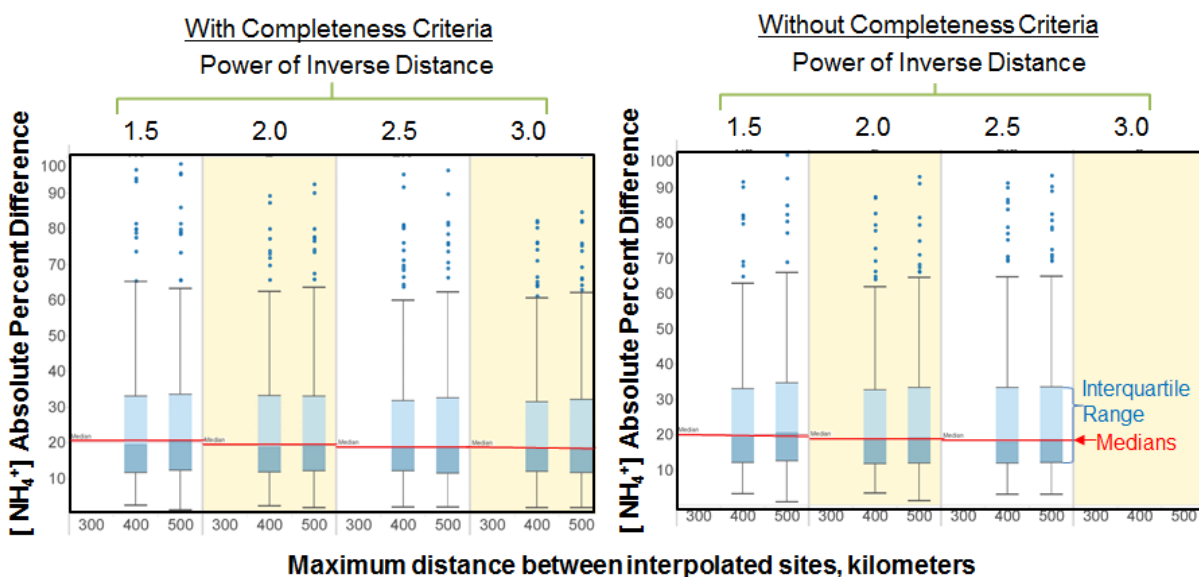

Figure 10. Absolute percent differences for jackknife analysis of inverse distance-weighted interpolation error for NTN annual precipitation-weighted mean ammonium concentrations, with and without annual record censoring per NADP data completeness criteria.

The results in Figure 10 indicate that there is very little difference in NH_4^+ MAPD using different powers of IDW. The minimum distance between points did not have much effect on NH_4^+ MAPD either. The interquartile ranges of absolute percent differences for the dataset subject to completeness criteria censoring are slightly smaller than the interquartile ranges for data without application of the completeness criteria. Maps of the site-specific NH_4^+ MAPD for data censored with completeness criteria and with no application thereof are shown in Figure 11. There were only two regions (circled) in which a total of seven sites had differences in NH_4^+ MAPD, with higher MAPD for data without completeness criteria censoring. Both of the circled areas have high-elevation sites. Six sites indicated differences in precipitation-depth MAPD for data censored with and without completeness criteria. Each of those sites are in regions that receive a substantial portion of their annual total precipitation as snow. Results for NO_3^- are similar but not shown.

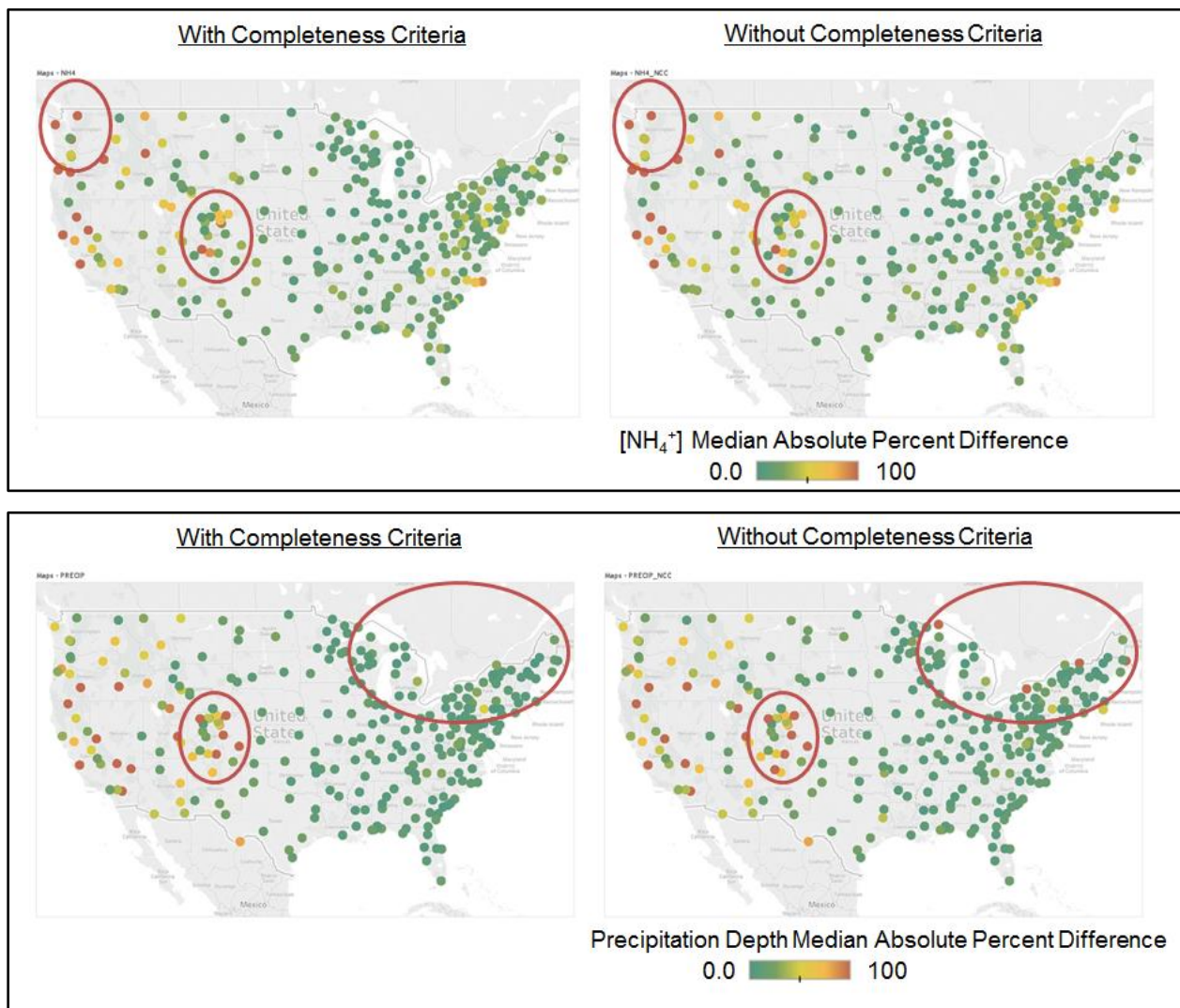

Figure 11. Site-specific MAPDs for jackknife analysis of inverse distance-weighted interpolation error for NTN annual precipitation-weighted mean ammonium concentrations and annual precipitation depth, with and without annual record censoring per NADP data completeness criteria.

The jackknife analyses lead to the following conclusions for wet deposition Nr species monitoring by NADP:

1. Criterion 1 could be relaxed slightly to 60–65% with only slightly increased error, but an increased number of sites would be included in the NADP's interpolated raster products. It is unknown how many sites could be added in any given year. The addition of just one site in a region with sparse site density, such as the western half of the nation, could influence the interpolated raster.
2. Criterion 2 is appropriate at 90% minimum precipitation-depth record completeness.
3. Criterion 3 could be relaxed to 65–70% with only slightly increased error and slight positive bias, but an increased number of sites would be included in the NADP's

interpolated raster products. Although less than a 10% increase in the number of sites is expected, their inclusion could greatly influence the interpolated raster in sparsely represented regions of the nation.

4. Use of completeness criteria does not significantly improve error in IDW interpolations.
5. The analysis did not account for dependencies in the occurrence of invalid samples on season and precipitation depth. Future analyses should include these dependencies.

Future research

The results of the analyses underscore the need for additional evaluation of NADP protocols for data validation, completeness criteria, and precipitation-weighting techniques. Future discussion of this subject within the NADP should focus on objective means to evaluate which protocols are needed and which ones should be changed. The following specific studies and actions would be helpful toward that end:

Near term

1. Data validation methods
 - a. Evaluate and establish alternative methods for determination of what constitutes a contaminated sample. This is especially important for new sites with few records of chemical concentrations, as analyte concentrations of samples with visible debris are evaluated to determine whether they exceed the 95th percentiles for the site. Therefore, as the records acquire more data, the probability of obtaining a contaminated sample decreases. This evaluation could be taken up by the interagency members of the NADP Quality Assurance Advisory Group.
 - b. Move forward with making invalid weekly data more readily available for research purposes. These data are available by request. However, if properly flagged, described, and served on the web, these data will more readily allow scientists to make their own data assessments and calculations. This is important for transparency, computation of uncertainty and bias, and creation of new data screening protocols.
 - c. Analyze collocated data to better understand and quantify the errors and biases in the data flagged as invalid, including samples that are left in the field for extended sampling durations and those that are exposed to dry deposition.
2. Completeness criteria
 - a. Extend the completeness criteria assessment to include the dependencies of the invalid samples on season and precipitation depth. Also, extend the analyses to other analytes beyond ammonium and nitrate.
 - b. Evaluate the effects of alternative data imputation methods on the data completeness criteria.
 - c. Evaluate whether alternative methods for data completeness assessment and precipitation weighting for annual mean concentrations improve TDep spatial

variability models. This work could be done by the interagency members of the NADP Total Deposition Science Committee.

3. Data imputation
 - a. Develop and evaluate data imputation methods that properly account for the concentration seasonal and precipitation dependencies across space and time and that can be applied across the NADP/NTN network.
 - b. Assess the change in errors and biases in the annual precipitation-weighted mean concentrations using the NADP default and alternative data imputation methods.
 - c. Evaluate alternative methods for precipitation weighting for annual mean concentrations, including using substitute precipitation data from nearby gauges and accounting for variations over time. Determine whether the alternative methods improve TDep spatial representation. This work could be done by the interagency members of the NADP Total Deposition Science Committee.
4. Wet deposition monitoring
 - a. Evaluate differences in frequencies and types of sample invalidation among different wet-only collectors (i.e., Aerochem versus N-CON versus MIC-type collectors). This study could be initiated by the U.S. Geological Survey (USGS) and Environment and Climate Change Canada, who collaborate on collocated precipitation sample collection at NADP sites CAN5 and PA15 (Sirois et al., 2000; Wetherbee et al., 2010.)
 - b. Compare reliability and functionality of optical precipitation sensors that can operate in remote areas on battery or solar power to improve precipitation catch. Data collected at the NADP Program Office's proposed research site in Madison, Wisconsin, by an array of sensors could inform this investigation. Additional work could be done by the NADP Program Office in collaboration with the USGS.

Long term

1. Develop techniques and instrumentation for
 - a. collection of representative backup samples to augment incomplete sampling intervals (e.g., weekly bulk snow collectors). The USGS has proposed this research at NADP sites in national parks, such as the CO98 site in Loch Vale, Colorado;
 - b. collection of more-representative samples (for example, through the use of collector windshields and bird-proofing collectors, debris exclusion, lid seal improvements, operator training, real-time monitoring, etc.). There are opportunities for collaboration between NADP sponsoring agencies and academia for these studies.
2. Evaluate special protocols for monitoring extreme events and adverse weather conditions, especially for high-altitude and coastal sites. Opportunities for collaboration

between the NPS, the USGS, and Colorado State University could be explored for such studies, which could be done at coastal and high-altitude NADP sites that are readily accessible, such as MA01, ME96, SC05, CA50, CA99, and CO94.

References

- Andronache, C. (2004). Precipitation removal of ultrafine aerosol particles from the atmospheric boundary layer. *Journal of Geophysical Research-Atmospheres* 109(D16), 10.
- Barrie, L. A. (1981). The prediction of rain acidity and SO₂ scavenging in eastern North America. *Atmospheric Environment* 15(1), 31-41.
- Barrie, L. A. (1985). Scavenging ratios, wet deposition, and in-cloud oxidation – An application to the oxides of sulfur and nitrogen. *Journal of Geophysical Research-Atmospheres* 90(ND3), 5789-5799.
- CDPHE (2007). Colorado Department of Public Health and Environment. Rocky Mountain National Park Nitrogen Deposition Reduction Plan. <https://www.colorado.gov/pacific/cdphe/rocky-mountain-national-park-nitrogen-reduction-plan>. Accessed April, 2019.
- Collett, J. L.; A. S. H. Prevot; J. Staehelin; A. Waldvogel (1991). Physical factors influencing winter precipitation chemistry. *Environmental Science & Technology* 25(4), 782-788.
- Kasper-Giebl, A.; M. F. Kalina; H. Puxbaum (1999). Scavenging ratios for sulfate, ammonium and nitrate determined at Mt. Sonnblick (3106 m a.s.l.). *Atmospheric Environment* 33(6), 895-906.
- Hollander, M.; D. A. Wolfe (1999). *Nonparametric Statistical Methods*, 2 ed., John Wiley and Sons, Inc., New York, p. 165.
- Lehmann, C. M. B.; V. C. Bowersox; S. M. Larson (2005). Spatial and temporal trends of precipitation chemistry in the United States, 1985-2002. *Environmental Pollution* 135, 347-361.
- Lynch, J. A.; D. R. DeWalle, K. Horner (1989). Impact of NADP/NTN Sampling Protocols on Winter Storm Estimates of Wet Deposition in Central Pennsylvania; Penn State ERRI Report ER8905, Penn State Environmental Resources Research Institute, University Park, Pennsylvania, 27 p.
- NADP (2016a). National Atmospheric Deposition Program. NADP Network Quality Assurance Plan, Version 1.8. NADP Program Office, Wisconsin State Laboratory of Hygiene, Madison, WI, 29 p., https://nadp.slh.wisc.edu/lib/qaplans/NADP_Network_Quality_Assurance_Plan.pdf.
- NADP (2016b) National Atmospheric Deposition Program. NADP Quality Management Plan, Version 1.8; NADP Program Office, Wisconsin State Laboratory of Hygiene, Madison, WI, 31 p., http://nadp.sws.uiuc.edu/lib/qaplans/NADP_QMP.pdf.

Pratt, G. C.; S. V. Krupa (1983). Seasonal trends in precipitation chemistry. *Atmospheric Environment* 17, 1845–1847.

Raynor, G. S.; J. V. Hayes (1982). Variation in chemical wet deposition with meteorological conditions. *Atmospheric Environment* 16, 1647–1656.

Schichtel, B. A.; R. B. Husar (1997). Regional simulation of atmospheric pollutants with the CAPITA Monte Carlo model. *Journal of the Air & Waste Management Association* 47(3), 331-343.

Sirois, A.; R. Vet; D. Lamb (2000). A comparison of the precipitation chemistry measurements obtained by the CAPMoN and NADP/NTN networks. *Environmental Monitoring and Assessment* 62, 273–303.

Wetherbee, G. A.; M. J. Shaw; N. E. Latysh; C. M. B. Lehmann; J. E. Rothert (2010). Comparison of precipitation chemistry measurements obtained by the Canadian Air and Precipitation Monitoring Network and National Atmospheric Deposition Program for the period 1995–2004. *Environmental Monitoring and Assessment* 164, 111–132.

Wetherbee, G. A.; M. A. Mast (2016). Annual variations in wet-deposition chemistry related to changes in climate. *Climate Dynamics* 47, 3141–3155.

3.1.2.2. Satellite measurements of oxidized and reduced nitrogen for application to Nr budgets

Gregory M. Beachley¹, Daniel Tong²

¹ U.S. EPA, Office of Air Programs, Washington, DC

² George Mason University and NOAA Air Resources Laboratory, College Park, MD

Research topic summary

Satellite remote sensing detection of atmospheric trace pollutants is a fast-evolving technology that shows great promise for complementing existing surface monitoring data. For the field of reactive Nitrogen (Nr) deposition, the technique is limited to observing NO₂ and NH₃ though apriori knowledge of atmospheric transformation and deposition processes can be used to draw conclusions about other species in the Nr budget. Optical instruments aboard satellites measure data that are translated into total vertical column densities (VCD; e.g. NO₂ measured by the Ozone Monitoring Instrument; OMI) and/or vertical profiles with maximum sensitivity in the lower boundary layer, where values of some species (e.g. NH₃) are highly correlated with those at the surface level (e.g. Cross-track Infrared Sounder; CrIS). Often the satellite measurements of trace species have limited independent information at the surface with in the lower troposphere values being highly correlated with the surface concentrations. There has been much recent work in the past two decades to optimize this correlation using retrieval algorithms in determining a usable satellite data product. This data product is subsequently used in measurement-model fusion approaches that relate satellite observations, surface monitoring observations, and chemical transport models (CTM) for applications in air monitoring research, particularly in analysis of surface level concentrations and transport, emissions source quantification, and pollutant deposition.

For applications to Nr deposition, the current research needs in the remote sensing field fall into two categories: 1) the improvement and refining of the satellite-derived data products to better represent surface-level air concentrations and 2) the application of the satellite-derived lower tropospheric data products to further address research questions relevant to the development of total Nr deposition budgets. The first represents more of a long-term research need, though there is currently a lot of research focused on this problem and the field is rapidly advancing. New instrument technologies and new missions will improve on spatial and temporal resolution and new data retrieval methods will help to optimize the data products, but many of these research needs will be pursued by scientists and physicists outside of the field of deposition. There are committees available (e.g. NASA Health and Air Quality Applied Sciences Team; HA-QAST) to provide deposition scientists an opportunity to actively advocate

for new technologies and refined data products specifically geared for their research needs. Increased collaboration with these groups through stakeholder outreach opportunities built into programs such as HA-QAST and is a near-term goal. Additionally, there are existing collaborations for remote-sensing scientists to utilize existing monitoring network sites for instruments such as vertical profiling monitors (e.g. PANDORA) to better characterize aloft profiles for improved retrievals.

In regards to air monitoring applications, many of the research needs are near-term as they build on existing research and modeling approaches. This includes the further evaluation of lower tropospheric level data products with surface measurements and land-use types to: improve extrapolation techniques in hybrid deposition mapping approaches (e.g. data fusion), to gain a better understanding of synoptic-scale atmospheric chemical processing and transport, to improve the ability to use measured species as surrogates for species that are not optically detectable from space, and to better understand the variability and uncertainty of emissions inventories for measured and non-measured point sources, area sources, and episodic events.

Finally, there is a need to characterize the variability and uncertainty in the retrieved satellite data product under a range of atmospheric conditions and in terms of the applications for which they are being used. For example, the uncertainties in retrieved surface concentrations are often less than the large uncertainties in modeled dry deposition velocities (which can exceed a factor of 2 or more) especially over highly variable land-use types within modeling grid cells.

Introduction

A 2014 assessment of global precipitation chemistry and deposition surveyed international pollution monitoring networks and identified major gaps and limitations which led to key uncertainties between point surface measurements and gridded model estimates (Vet et al., 2014). Regarding the assessment of Nr, these gaps included the limited spatial and temporal coverage of surface monitoring of air concentrations, the lack of important ecologically significant Nr species (e.g. NH_3 , HNO_3 , NO_2 , organic nitrates), the lack of understanding of key process-level mechanisms including dry deposition velocities over different land-use types and for different species, and the effect of precipitation washout (Vet et al., 2014). The development of satellite remote sensing measurements for complementary use with surface air monitoring appears to be the only logistically feasible way to adequately address some of those needs.

Remote sensing measurements are collected with electromagnetic radiation spectroscopy instruments installed on Earth-orbiting satellites that are operated by the National Aeronautics and Space Administration (NASA), European Space Agency (ESA), National Oceanic and Atmospheric Administration (NOAA) and other space agencies. Atmospheric trace gases are monitored via gas-specific wavelengths of either solar backscatter or thermal infrared emission

(Martin, 2008). Solar backscatter determines atmospheric abundance by calculating the attenuation in the intensity of radiation traversing the atmosphere. The thermal infrared emission approach infers the abundance of trace gases based on spectral variation in absorbed and emitted radiation. Each approach generates vertical trace gas amounts that can be inferred from the raw signal using retrieval algorithms and a priori estimates or bounds obtained from CTMs. Satellite observations cannot provide surface level (i.e. “nose-level”) concentrations, but for short-lived species with low background levels that are concentrated in the lower levels of the atmosphere (e.g. NO_2 and NH_3), surface concentrations can be derived from VCD using a combination of satellite-based column densities and model-based vertical profiles (Duncan et al., 2014) if profile retrievals are not possible. Concurrent with the improvements in the instruments are improvements in the radiative transfer and retrieval algorithms that are used to derive near-surface level products that are applicable to surface monitoring data. As the spatial resolutions of these data products improve, remote sensing data becomes more applicable to atmospheric concentrations and deposition of Nr at smaller scales.

Remote sensing capabilities of near-surface Nr species include NH_3 and NO_2 , but do not include other key species (particularly HNO_3 and organic nitrogen compounds) within the total Nr deposition budget. However, this does provide a representation of oxidized and reduced Nr components. Studies have found that tropospheric VCDs correlate well with observed surface monitoring concentrations for NO_2 (Velders et al., 2001; Richter and Burrows, 2002; Lamsal et al., 2008, 2010) and NH_3 (Beer et al., 2008; Clarisse et al., 2009, 2010; Shephard et al., 2011). Remote sensing measurements are advantageous because of their capacity for simultaneous spatial coverage over large regions, especially in areas where traditional surface sampling methods are inadequate (e.g. in remote or inaccessible locations). Thus, the data are increasingly used to estimate emissions, trace pollution plumes and transport, monitor long-term trends, and evaluate air quality model output (Duncan et al., 2014).

All satellite remote sensing instruments monitoring short-lived nitrogen species (e.g. NH_3 and NO_2) are currently carried by polar-orbiting satellites, which provides twice daily overpasses (infrared providing two observations and visible one observation per day). Since the lower atmosphere can only be scanned in relatively cloud-free conditions, satellite estimations of lower tropospheric amounts generally require multiple overpasses and are reported as aggregates over a certain amount of time. As instrument sensitivities improve, the number of overpasses needed to make a confident aggregate measurement decreases and the temporal resolution of the satellite data product will increase. The local overpass time of the satellite can be an important factor. For example in the infrared, the greater thermal contrast in the middle of the day generally provides improved instrument sensitivity. However, the different overpass times from different satellites provide more information on the diurnal patterns (e.g. the NH_3 sensing instruments of Infrared Atmospheric Sounder Interferometer (IASI) aboard MetOp-A satellite has local daily overpass times of ~09:30 and 21:30, (Clerbaux et al, 2009) while CrIS

aboard Suomi National Polar-orbiting Partnership (NPP) satellite has overpass times of ~01:30 and 13:30 (Shephard and Cady-Pereira, 2015). The planned launch of Tropospheric Emissions: Monitoring of Pollution (TEMPO) in 2021 aboard a commercial geostationary satellite, will be the first sensor that can provide hourly observations of NO₂ over North America, but will not detect NH₃ (Hilsenrath and Chance, 2013; Zoogman et al., 2017). Similar geostationary sensors are also planned over Europe (Sentinel-4) and Asia (GEMS) in similar timeframes.

In addition to temporal resolution, the spatial resolution of concentration grids generally becomes finer with the improved sensitivity of each instrument. As an example, the recently launched TROPOMI (TROPOspheric Monitoring Instrument) aboard the Sentinel-5P mission (2015 launch) has a 7 x 7 km² target ground pixel size (KNMI, 2018) improving on the ground pixels size of 13 x 24 km² of OMI (Levelt et al., 2006) launched aboard the Aura satellite in 2004.

State of the science

Monitoring instruments and data algorithms to produce usable data product

Early development of remote sensing technology has been focused on the ability to “retrieve” consistent and accurate boundary-layer concentrations of trace-level atmospheric pollutants from different optical instruments on different satellite missions. Remote sensing capabilities are the most well-developed for NO₂ with good correlations between tropospheric VCD and observed surface concentrations reported (Velders et al., 2001) and methods developed to estimate surface NO₂ from OMI NO₂ VCD data using the GEOS-Chem model (Lamsal et al., 2008, 2010). With these methods, Lamsal et al. (2015) showed good agreements with linear trends from 2005 to 2013 in OMI NO₂ data and urban surface NO₂ concentrations observed by EPA Air Quality System (AQS) monitors, Duncan et al. (2013) demonstrated good agreement of OMI NO₂ VCD data above electrical generation unit (EGU) sources with EPA Continuous Emissions Monitoring Systems (CEMS) data, and Geddes and colleagues (2015) reconstructed long-term trends (1996 to 2012) of ambient NO₂ concentrations worldwide using NO₂ column observations from Global Ozone Monitoring Experiment (GOME), Scanning Imaging Absorption Spectrometer for Atmospheric Chartography (SCIAMACHY) and GOME2.

Compared to NO₂, NH₃ has fewer satellite datasets although several sensors have shown impressive skills to detect NH₃ from space. The first satellite observations of NH₃ were derived from the Tropospheric Emission Spectrometer (TES) (Beer et al., 2008) aboard the Aura satellite launched in 2004. Since then lower tropospheric NH₃ has been retrieved from the IASI aboard the MetOp-A (launched 2006) and MetOp-B (launched 2012) satellites (Clarisse et al., 2010), the Atmospheric Infrared Sounder (AIRS) aboard the Aqua satellite (launched in 2002) (Warner et al., 2016), and CrIS aboard the Suomi-NPP satellite (launched in 2011) and NOAA-20 (launched in 2017) (Shephard and Cady-Pereira, 2015). Both TES and IASI were the first to observe spatial and seasonal distributions of tropospheric NH₃ concentrations from regional to

global scales (Beer et al., 2008, Clarisse et al., 2009; Shephard et al., 2011). AIRS observations have recently been used to identify long-term increasing trends in atmospheric NH₃ concentrations over several major agricultural regions from 2002 to 2016 (Warner et al., 2017). The most recent NH₃ products have been derived from CrIS, which has the good spatial coverage (similar to AIRS and IASI), but greater sensitivity than the other instruments due to lower measurement noise (Shephard and Cady-Pereira, 2015). The potential of the satellite NH₃ observations for applications such as emissions (e.g. Adams et al., 2019) and dry deposition (e.g. Kharol et al., 2018) are emerging. Currently, the two most commonly used satellite NH₃ datasets are from IASI and CrIS, and this will likely continue into the future as there are three more planned launches of the CrIS instrument extending its monitoring program into 2038, and there are future IASI (out to 2021) and follow-on IASI-NG (2021-2042) launches planned.

Applications of remote sensing data products to Nr deposition

Surface concentrations and variability

As confidence has grown in the accuracy and consistency of remotely detected atmospheric concentrations, recent research has pursued ways to utilize this resource. Because satellite data has limited independent information on surface level concentrations, many applications use a measurement-model fusion approach. Modeled vertical concentration densities can be correlated or constrained with aloft VCD data and modeled surface concentrations can be correlated or constrained with measured surface concentrations.

The short atmospheric lifetimes of the detectable Nr species (as described above) also means they have very heterogenous concentration distributions which can be difficult to account for in traditional surface monitoring network layouts. Pinder et al., (2011) used TES NH₃ data to find good correspondence with seasonal and spatial variability in 25 surface monitoring locations over a high agricultural source density in eastern North Carolina, indicating the potential of satellites to resolve large spatial and temporal variability. Because of the spatial coverage of satellite data, this is directly relevant to understanding and improving measurement representativeness and extrapolation methods for measurement-model fusion mapping techniques such as the TDep method and ADAGIO project (see Sections **3.2.4. Assessing uncertainty in total Nr deposition estimates for North American critical load applications and 3.4.2. Spatial variability of ammonia in agricultural regions**). Furthermore, measurement-model fusion applications can be used to identify and correct bias in CTMs. Schiferl et al., 2016 used IASI observations along with surface and aircraft measurements in GEOS-Chem runs to investigate surface NH₃ concentrations and variability during summer months over a 5-yr period from 2008-2012 and found GEOS-Chem underestimated NH₃ concentrations near large source regions and the inter-annual variability in surface concentrations citing the primary driver as changes in meteorology (especially in controlling the gas-particle phase partitioning). In addition, Schiferl et al. (2016) also reported that reductions in SO₂ and NO_x emissions contributed to variability in trends showing how satellites used in conjunction with other

measured and modeled species and meteorology can provide information on long-term trends in atmospheric chemistry. Lonsdale et al. (2017) used both TES NH₃ data and diurnal surface NH₃ observations to reduce CMAQ model bias in Bakersfield, CA.

While remote sensing data are subject to their own degree of uncertainty, there are no sampling biases such as those widely reported for NH₃ (von Bobruzki et al., 2010) which may contribute to low biases in bottom-up emissions inventories (Walker et al., 2012) and may factor in low bias of modeled NH₃ concentrations using those emissions (Bray et al., 2017; Schiferl et al., 2016; Lonsdale et al., 2017). There are similar measurement (chemical conversion, stability) issues that manifest for chemiluminescence NO_x detection techniques where satellite data not subject to those biases may prove useful.

As noted above, another benefit of satellite data, especially on operational missions, is the duration of the measurements (on the order of 5-10 years per satellite, with the same instrument flown on several satellites providing potential for 20+ years of observations) which provide excellent datasets to investigate long-term trends (e.g. Martin et al., 2003; Lamsal et al., 2015; Warner et al., 2016; Warner et al., 2017). Many studies combine data from different satellite missions to increase the timespan coverage of the dataset (e.g. Cheng et al., 2013; Nowlan et al., 2014; Geddes and Martin, 2017).

Improved instrument capabilities and retrieval methods have increased the signal-to-noise of the observations and reduced the averaging time of valid overpasses needed to obtain confident results for analysis of trends over annual and seasonal scales (Lu et al., 2015). Tong et al. (2015) compared multi-year NO_x trends derived from satellite and ground observations and uses these data to evaluate the updates of NO_x emission data by the US National Air Quality Forecast Capability (NAQFC) during the 2008 Global Economic Recession. Over the eight large US cities examined here, both OMI and AQS datasets display distinct emission reduction rates before, during, and after the 2008 global recession in some cities, but the detailed changing rates are not consistent across the OMI and AQS data. They demonstrate the feasibility of using space and ground observations to evaluate major updates of emission inventories objectively (Tong et al., 2015).

Emissions

Streets et al., (2013) reviewed the applications of satellite techniques to quantify emissions and included the quantification of point-source emissions, of more uncertain area sources and episodic events and source transport. These applications are directly relevant to improvement of source apportionment methods. Much work is focused on obtaining regional emissions estimates using inverse modeling techniques with CTMs. Satellite observations can be used as “top-down” constraints on “bottom-up” constructed emissions inventories, thus improving the accuracy of the modeled results. This has been well-validated for NO_x emissions and the improvements in emissions are validated by comparisons with surface measurements from monitoring networks (e.g., Martin et al., 2003; Martin et al., 2006; Konovalov et al., 2006; Kim et al., 2009; Lamsal et al., 2011). This technique has been recently applied to investigate NH₃

emissions using the TES and inverse GEOS-Chem leading to improved agreement between modeled concentrations and monthly aggregated NADP/AMON surface NH_3 concentrations and to a lesser degree NADP/NTN wet deposition of NH_4^+ (Zhu et al., 2013). Whaley et al., (2018) used CrIS, aircraft, and surface monitoring NH_3 data to evaluate the GEM-MACH model with emissions from forest fires and bi-directional NH_3 air-surface exchange included.

Recent studies have also been focused on quantifying and identifying specific point and area source emissions of NO_x . There has been considerable development in quantifying averaged emissions and lifetimes of NO_2 of specific point sources or urban areas using rotated wind fields and Gaussian plume decay fits (Leue et al., 2001; Bierle et al., 2004; Bierle et al., 2011; Valin et al., 2013; de Foy et al., 2014). This technique has been applied to isolated EGUs (de Foy et al., 2015) and cities (Lu et al., 2015) and for urban areas situated in high-background polluted areas (Liu et al., 2016). Lu et al., (2015) demonstrated the technique sufficiently robust to reduce the averaging times to annual aggregates thus allowing the investigation of annual emission trends. This technique shows great promise particularly with the launch of more sophisticated monitors with higher spatial resolutions (from GOME to OMI to presently TROPOMI) and will advance significantly with the anticipated launch of the geostationary TEMPO that will result in significant improvements in spatial and temporal resolutions. The technique has also been coupled with *a priori* information such as measured stack emissions already in place in the U.S. (Duncan et al., 2013) and known *a priori* atmospheric transformation rates and emissions ratios (Fioletov et al., 2015; Wang et al., 2010) to assess emission rates for plants without monitored emissions.

Research into the capabilities to remotely quantify NH_3 emissions directly from remote measurements are underway (Shephard et al., 2018) but significant challenges remain given the longer lifetime of NH_3 , its propensity for reversible deposition and atmospheric processing, and the uncertain and highly variable nature of its emission sources both in terms of magnitude and time of emission (Hristov et al., 2011).

Another application is to use satellite derived concentration ratios for source apportionment. Whitburn et al., (2015) analyzed monthly aggregate IASI NH_3 and CO columns and used them with fire radiative power measurements derived from MODIS to compare satellite derived NH_3 and CO concentrations associated with fires and compared them with those in existing biomass burning emissions inventories. Luo et al., (2015) used global TES-derived NH_3 and CO ratios to compare with GEOS-Chem simulations and found agreement in global distribution patterns. This technique may be useful in characterizing the influence of episodic deposition events such as biomass burning to total N_r deposition in some areas (see Section **3.1.2.5. Characterization of organic nitrogen in air and precipitation**).

Deposition

A number of recent studies have expanded on measurement-model surface concentration techniques to directly explore the use of satellite data to estimate deposition or to provide constraints for deposition estimates.

Cheng et al., (2013) used exploratory correlations of GOME and SCIAMACHY VCD data with local surface NO₂ measurements in three regions and input that adjusted VCD data into a resistance based empirical dry deposition model (Wesely and Hicks, 2000) to get parameterized deposition velocities based on satellite derived (Environmental Satellite Medium Resolution Imaging Spectrometer; ENVISAT/MERIS) land-use categories. Lu et al., (2013) attempted a different approach on a global scale, assuming that tropospheric NO₂ column densities (also from GOME and SCIAMACHY) were related to surface concentrations and input that data into a multilinear regression model as an approximation of dry deposition. That output was combined with wet deposition data, assumed as a linear relationship to precipitation volume, to obtain approximated total deposition fluxes which were then compared against output from a CTM (MOZART-4; Model for Ozone and Related Chemical Tracers version 4; Emmons et al., 2010).

Nowlan et al. (2014) expanded on the approaches described above by using Lamsal et al. (2008)'s method of OMI data in conjunction with GEOS-Chem simulations to generate tropospheric NO₂ column measurements. These were coupled with deposition velocities calculated from GEOS-Chem using the USGS global land characteristics database and leaf-area indexes (LAI) derived from MODIS (Moderate Resolution Imaging Spectrometer) observations. They reported good agreement between OMI-derived NO₂ fluxes and modeled (or observed fluxes) and for OMI-derived fluxes and SO₂ fluxes from CASTNET. Jia et al., (2016) used Nowlan's approach and expanded the empirical dry deposition models introduced by Cheng et al. (2013) to use OMI NO₂ columns to estimate surface concentrations of NO₂, total nitrate (in gaseous and particulate forms), and NH₄⁺ (in NH₄NO₃) based on atmospheric chemical reactions. Their methods provided global estimates and used over 500 monitoring sites

Geddes and Martin (2017) expanded on the approach used by Nowlan et al. (2014) by using the GOME, SCIAMACHY, and GOME-2 VCD NO₂ to constrain NO_x emissions in an inverse modeling approach and subsequently used GEOS-Chem to model total NO_y deposition from 1996 to 2014 including unmeasured oxidized species and wet deposition of NO_y. Kharol et al. (2018) also used an approach similar to Nowlan et al. (2014), but applied it to satellite VCDs of NO₂ (OMI) and surface retrieved NH₃ (CrIS) across North America. The satellite observations were coupled with modeled dry deposition velocities generated from the GEM-MACH model (Gong et al., 2015) meteorological data with a unidirectional big-leaf model and MODIS-derived data for land use/land cover and leaf area index (LAI) averages to approximate dry deposition fluxes.

Future research

The field of remote sensing data is fast-evolving due to the clear demonstration that remote sensing data can improve the field of atmospheric trace gas monitoring by providing temporal and spatial coverage at a scale that cannot be duplicated by surface monitoring efforts. The outlook for remote sensing data applications are as a complimentary tool to augment data from surface monitoring networks rather than as a replacement.

Current knowledge gaps in the remote sensing field relevant to atmospheric deposition exist in two main categories: 1) the improvement and refining of the VCD satellite-derived products (e.g. TropOMI NO₂) so that they better represent surface-level air concentrations and 2) the applications of the satellite derived lower tropospheric data products to address research questions relevant to the development of total Nr deposition budgets. The first category is well underway, but further improvements will require scientific research on resolving the vertical concentration profiles used in retrieval methods. These are generally based on past observations made with aircraft or sonde and the input profiles are designed to be representative of different conditions (e.g. initial *a priori* vertical NH₃ profiles exist for polluted, moderate, and unpolluted conditions; Shephard and Cady-Pereira, 2015). More characterization of these vertical concentration profiles for different conditions and different species may help to improve on the accuracy of the retrievals. In addition to aircraft and sonde techniques, recent studies have used FT-IR spectrometers (Dammers et al., 2015; 2016; 2017) and solar zenith angle sun photometers for vertical NO₂ columns (PANDORA; Herman et al., 2009).

A second aspect to improving the quality of the data product is the deployment of newer sensors. While this is obviously a long-term effort, monitoring spectrometers have steadily improved over the course of the past two decades (e.g. GOME → OMI → TropOMI) and will likely continue to do so. Current satellite data is limited to one (for UV-VIS instruments requiring sunlight) or two (for thermal infrared instruments) daily overpasses during sunlit hours and those overpasses are frequently impacted by cloud-cover. The deployment of the geo-stationary satellites equipped with atmospheric sensing equipment (e.g. TEMPO) in 2021 will revolutionize the capacity and utility of satellite measurements with hourly scans (i.e. temporal resolution), spatial resolution, and continental coverage. This planned deployment will detect NO₂, but not NH₃, so techniques and studies will be focused on developing applications for the oxidized component of Nr until a geostationary mission with a sensor capable of imaging NH₃ is deployed. In the meantime, datastreams and data handling is being vetted using current geostationary weather forecasting satellites (GOES-R launched in 2016).

These research needs will be met by scientists outside of the field of Nr deposition, but the use of these satellite data products is fostered and the NASA HA-QAST committee (formerly AQAST) <https://haqast.org/> (accessed October 4, 2018) exists to help the transition of often complicated data products into the hands of scientists and analysts that use them. Participation in such committees by the Nr-deposition focused community is encouraged to help utilize the existing suite of data products and advocate for needs or improvements to those products. From the applications vantage point, more work to characterize the variability of surface concentrations and the representativeness of ground monitors is needed. Investigation of the use of satellite data in improving extrapolation techniques of point surface measurements currently used in measurement-model fusion mapping methods (see Section **3.2.4 Assessing uncertainty in total Nr deposition estimates for North American critical load applications**) is needed. These fusion maps are used heavily by the deposition and critical loads community and quantification and reduction in uncertainties for these estimates are needed.

Modeling platforms and source apportionment techniques would greatly benefit from reducing uncertainties in emissions estimates for Nr. Uncertainties in emissions databases exist for both oxidized and reduced Nr, with agricultural and area sources especially difficult to quantify. Methods exist for using remote sensing data to investigate this area and studies are needed to couple this data with ample surface measurements to further characterize sources by emission type and strength (see Section **3.4.2 Spatial variability of ammonia in agricultural regions**).

In addition, there will be much work to understand and attempt to quantify the uncertainty of the retrieved satellite data. At this stage, correlations with surface monitoring and model predictions are the only criteria for accuracy. As the satellite data are inferred observations of surface concentrations made from observed radiance data, the relationship will require further validation efforts over many different conditions and time intervals.

With its global coverage, satellite data may prove a useful tool in answering key questions of chemical conversion and transport. This may be useful in observing reversible processes under varying meteorological conditions, such as the bidirectional deposition of NH₃ and the conversion of NH₃ to NH₄⁺. There already exists a body of work in understanding of atmospheric chemical relationships between NO_x compounds, and using the measurable NO₂ to draw conclusions about the emitted NO_x (Lamsal et al., 2008; 2011; Tong et al., 2015). This type of application will be helpful in source apportionment applications and help in understanding the significance of episodic deposition events from sources such as biomass burning (Adams et al., 2019). Many of these focused knowledge gaps are near-term in that the existing technology to conduct these types of studies is in place. Enhanced coordination between deposition scientists, modelers, and the HA-QAST outreach group could help plan these studies and develop feasible courses of action.

References

Adams, C., McLinden, C. A., Shephard, M. W., Dickson, N., Dammers, E., Chen, J., Makar, P., Cady-Pereira, K. E., Tam, N., Kharol, S. K., Lamsal, L. N., Krotkov, N. A. 2019. Satellite-derived emissions of carbon monoxide, ammonia, and nitrogen dioxide from the 2016 Horse River wildfire in the Fort McMurray area, *Atmos. Chem. Phys.*, 19, 2577-2599. <https://doi.org/10.5194/acp-19-2577-2019>.

Aumann, H., Chahine, M., Gautier, C., Goldberg, M., Kalnay, E., McMillin, L., Revercomb, H., Rosenkranz, P., Smith, W., Staelin, D., Strow, L., Susskind, J. 2003. AIRS/AMSU/HSB in the Aqua Mission, Design, Science Objectives, and Data Products. *IEEE Rem. Sens.*, 41(2), 253-264. DOI: 10.1109/TGRS.2002.808356.

Beer, R., Glavich, T.A., Rider, D.M. 2001. Tropospheric emission spectrometer for the earth observing system's aura satellite. *Applied Optics* 40, 2356-2367.

Beer, R., Shephard, M.W., Kulawik, S.S., Clough, S.A., Eldering, A., Bowman, K.W., Sander, S.P., Fisher, B.M., Payne, V.H., Luo, M., Osterman, G.B., Worden, J.R. 2008. First satellite observations of lower tropospheric ammonia and methanol. *Geophys. Res. Lett.*, 35, L09801. doi:10.1029/2008GL033642.

Bray, C.D., Battye, W., Aneja, V.P., Tong, D., Lee, P., Tang, Y., Nowak, J.B. 2017. Evaluating ammonia (NH₃) predictions in the NOAA National Air Quality Forecast Capability (NAQFC) using in-situ aircraft and satellite measurements from the CalNex2010 campaign. *Atmos. Environ.*, 163, 65-76. <https://doi.org/10.1016/j.atmosenv.2017.05.032>.

Beirle, S., Platt, U., von Glasow, R., Wenig, M., Wagner, T. 2004. Estimate of nitrogen oxide emissions from shipping by satellite remote sensing, *Geophys. Res. Lett.*, 31, L18102. doi:10.1029/2004GL020312.

Beirle, S., Boersma, K. F., Platt, U., Lawrence, M. G., Wagner, T. 2011. Megacity Emissions and Lifetimes of Nitrogen Oxides Probed from Space. *Science*, 333, 1737-1739.

Chance K., Liu, X., Suleiman, R.M., Flittner, D.E., Al-Saadi, J., Janz, S.J. 2013. Tropospheric emissions: monitoring of pollution (TEMPO). *Proc. SPIE 8866, Earth Observing Systems XVIII, 88660D* (23 September 2013), <https://doi.org/10.1117/12.2024479>

Cheng, M., Jiang, H., Guo, Z., Zhang, X., Lu, X. 2013. Estimating NO₂ dry deposition using satellite data in eastern China, *Int. J. Remote Sens.*, 34, 2548–2565, <https://doi.org/10.1080/01431161.2012.747019>

Clarisse, L., Clerbaux, C., Dentener, F., Hurtmans, D., Coheur, P.F. 2009. Global ammonia distribution derived from infrared satellite observations, *Nat. Geosci.*, 2(7), 479–483, doi:10.1038/Ngeo55

Clarisse, L., Shephard, M.W., Dentener, F., Hurtmans, D., Cady-Pereira, K., Karagulian, F., Van Damme, M., Clerbaux, C., Coheur, P.F. 2010. Satellite monitoring of ammonia: A case study of the San Joaquin valley, *J. Geophys. Res.-Atmos.*, 115, D13302, doi:10.1029/2009jd013291

Clerbaux, C., Boynard, A., Clarisse, L., George, M., Hadji-Lazaro, J., Herbin, H., Hurtmans, D., Pommier, M., Razavi, A., Turquety, S., Wespes, C., Coheur, P. F. 2009. Monitoring of atmospheric composition using the thermal infrared IASI/MetOp sounder. *Atmos. Chem. Phys.*, 9,6041-6054, <https://doi.org/10.5194/acp-9-6041-2009>

Dammers, E., Vigouroux, C., Palm, M., Mahieu, E., Warneke, T., Smale, D., Langerock, B., Franco, B., Van Damme, M., Schaap, M., Notholt, J., Erisman, J. W. 2015. Retrieval of ammonia from ground-based FTIR solar spectra, *Atmos. Chem. Phys.*, 15, 12789–12803, <https://doi.org/10.5194/acp-15-12789-2015>

Dammers, E., Palm, M., Van Damme, M., Vigouroux, C., Smale, D., Conway, S., Toon, G. C., Jones, N., Nussbaumer, E., Warneke, T., Petri, C., Clarisse, L., Clerbaux, C., Hermans, C., Lutsch, E., Strong, K., Hannigan, J. W., Nakajima, H., Morino, I., Herrera, B., Stremme, W., Grutter, M., Schaap, M., Wichink Kruit, R. J. Notholt, J., Coheur, P.-F., Erisman, J. W. 2016. An evaluation of IASI-NH₃ with ground-based Fourier transform infrared spectroscopy measurements, *Atmos. Chem. Phys.*, 16, 10351–10368. <https://doi.org/10.5194/acp-16-10351-2016>

Dammers, E., Shephard, M., Palm, M., Cady-Pereira, K., Capps, S., Lutsch, E., Strong, K., Hannigan, J. W., Ortega, I., Toon, G. C., Stremme, W., Grutter, M., Jones, N., Smale, D., Siemons, J., Hrpcek, K., Tremblay, D., Schaap, M., Notholt, J. & Erisman, J. Willem. 2017. Validation of the CrIS fast physical NH₃ retrieval with ground-based FTIR. *Atmospheric Measurement Techniques*, 10 (7), 2645-2667.

de Foy, B., Wilkins, J. L., Lu, Z., Streets, D. G. Duncan, B. N. 2014. Model evaluation of methods for estimating surface emissions and chemical lifetimes from satellite data. *Atmos. Environ.* 98, 66–77, <https://doi.org/10.1016/j.atmosenv.2014.08.051>

de Foy, B., Lu, Z., Streets, D. G., Lamsal, L. N., and Duncan, B. N. 2015. Estimates of power plant NO_x emissions and lifetimes from OMI NO₂ satellite retrievals. *Atmos. Environ.*, 116, 1–11.

Duncan B.N., Prados A.I., Lamsal L.N., Liu Y., Streets D.G., Gupta P., Hilsenrath E., Kahn R.A., Nielsen J.E., Beyersdorf A.J., Burton S.P., Fiore A.M., Fishman J., Henze D.K., Hostetler C.A., Krotkov N.A., Lee P., Lin M., Pawson S., Pfister G., Pickering K.E., Pierce R.B., Yoshida Y., Ziemba L.D. 2014. Satellite data of atmospheric pollution for U.S. air quality applications: Examples of applications, summary of data end-user resources, answers to FAQs, and common mistakes to avoid. *Atmos. Environ.*, 94, 647-662.

Duncan, B.N., Yoshida, Y., de Foy, B., Lamsal, L.N., Streets, D., Lu, Z., Pickering, K.E., Krotkov, N.A. 2013. The observed response of the Ozone Monitoring Instrument (OMI) NO₂ column to NO_x emission controls on power plants in the United States: 2005e2011. *Atmos. Environ.* 81, 102-111, <https://doi.org/10.1016/j.atmosenv.2013.08.068>

Emmons, L. K., S. Walters, P. G. Hess, J. F. Lamarque, G. G. Pfister, D. Fillmore, C. Granier, A. Guenther, D. Kinnison, and T. Laepple. 2010. Description and Evaluation of the Model for Ozone and Related Chemical Tracers, Version 4 (MOZART-4). *Geoscientific Model Development* 3, 43–67.

Fioletov, V. E., McLinden, C. A., Krotkov, N., Li, C. 2015. Lifetimes and emissions of SO₂ from point sources estimated from OMI. *Geophys. Res. Lett.*, 42, 1969–1976, doi:10.1002/2015GL063148

Geddes, J. A., Martin, R. V., Boys, B. L., van Donkelaar, A. 2015. Long-Term Trends Worldwide in Ambient NO₂ Concentrations Inferred from Satellite Observations. *Environ. Health Persp.*, 124, 281–289, <https://doi.org/10.1289/ehp.1409567>

Geddes, J.A., Martin, R.V. 2017. Global deposition of total reactive nitrogen oxides from 1996 to 2014 constrained with satellite observations of NO₂ columns. *Atmos. Chem. Phys.* 17, 10071–10091. <https://doi.org/10.5194/acp-17-10071-2017>

Gong, W., Makar, P. A., Zhang, J., Milbrandt, J., Gravel, S., Hayden, K. L., MacDonald, A.M., Leith, W. R. 2015. Modelling aerosol cloud-meteorology interaction: A case study with a fully coupled air quality model GEM-MACH. *Atmospheric Environment*, 115, 695–715, <https://doi.org/10.1016/j.atmosenv.2015.05.062>

Herman, J., Cede, A., Spinei, E., Mount, G., Tzortziou, M., Abujassan, N. 2009. NO₂ column amounts from ground-based Pandora and MFDOAS spectrometers using the direct sun DOAS technique: Intercomparisons and application to OMI validation. *J. of Geophys. Res.* 114, D13307, doi:10.1029/2009JD011848

Hilsenrath, E., and K. Chance, 2013. NASA ups the TEMPO on monitoring air pollution. *NASA Earth Observer*. 25(2), 10–13.

Hristov, A.N, Hanigan, M., Cole, A., Todd, R., McAllister, T.A., Ndegwa, P.M, Rotz, A. 2011. Review: Ammonia emissions from dairy farms and beef feedlots. *Canadian Journal of Animal Science*, 91, 1-35, <https://doi.org/10.4141/CJAS10034>

Jia, Y., Yu, G., Gao, Y., He, N., Wang, Q., Jiao, C., Zuo, Y. 2016. Global inorganic nitrogen dry deposition inferred from ground- and space-based measurements. *Sci. Rep.* 6, 19810, doi:10.1038/srep19810pmid:26813440

Kharol, S.K., Shephard, M.W., McLinden, C.A., Zhang, L., Sioris, C.E., O'Brien, J.M., Vet, R., Cady-Pereira, K.E., Hare, E., Siemons, J., Krotkov, N.A. 2018. Dry Deposition of Reactive Nitrogen from Satellite Observations of Ammonia and Nitrogen Dioxide Over North America. *Geophys. Res. Lett.* 45, 1157-1166, <https://doi.org/10.1002/2017GL075832>

Koninklijk Nederlands Meteorologisch Instituut (KNMI). 2018. <https://www.knmi.nl/kennis-en-datacentrum/achtergrond/tropomi-sensing-the-troposphere-from-space>. Accessed Feb., 14th 2018.

Lamsal, L.N., Martin, R.V., van Donkelaar, A., Steinbacher, M., Celarier, E.A., Bucsela, E., Dunlea, E.J., Pinto, J.P. 2008. Ground-level nitrogen dioxide concentrations inferred from the satellite-borne Ozone Monitoring Instrument. *Journal of Geophysical Research* 113, D16308.

Lamsal, L.N., Martin, R.V., van Donkelaar, A., Celarier, E.A., Bucsela, E.J., Boersma, K.F., Dirksen, R., Luo, C., Wang, Y. 2010. Indirect validation of tropospheric nitrogen dioxide retrieved from the OMI satellite instrument: insight into the seasonal variation of nitrogen oxides at northern midlatitudes. *Journal of Geophysical Research* 115, D05302.

Lamsal, L.N., Martin, R.V., Padmanabhan, A., van Donkelaar, A., Zhang, Q., Sioris, C.E., Chance, K., Kurosu, T.P., Newchurch, M.J. 2011. Application of satellite observations for timely updates to global anthropogenic NO_x emission inventories. *Geophysical Research Letters* 28, L05810.

Lamsal L.N., Duncan, B.N., Yoshida, Y., Krotkov, N.A., Pickering, K.A., Streets, D.G., Lu, Z. 2015. U.S. NO₂ trends (2005-2013): EPA Air Quality System (AQS) data versus improved observations from the Ozone Monitoring Instrument (OMI). *Atmos. Environ.* 110, 130-145, <https://doi.org/10.1016/j.atmosenv.2015.03.055>

Levelt, P.F., van den Oord, G.H.J., Dobber, M.R., Malkki, A., Visser, H., de Vries J., Stammes, P., Lundell, J.O.V., Saari, H. 2006. The Ozone Monitoring instrument, *IEEE Transactions on Geoscience and Remote Sensing*, 44 (5), May 2006, 10.1109/TGRS.2006.872333

Lonsdale, C. R., Hegarty, J. D., Cady-Pereira, K. E., Alvarado, M. J., Henze, D. K., Turner, M. D., Capps, S. L., Nowak, J. B., Neuman, J. A., Middlebrook, A. M., Bahreini, R., Murphy, J. G., Markovic, M. Z., VandenBoer, T. C., Russell, L. M., Scarino, A. J. 2017. Modeling the diurnal variability of agricultural ammonia in Bakersfield, California, during the CalNex campaign, *Atmos. Chem. Phys.*, 17, 2721–2739, <https://doi.org/10.5194/acp-17-2721-2017>

Leue, C., Wenig, M., Wagner, T., Klimm, O., Platt, U., Jahne, B. 2001. Quantitative analysis of NO_x emissions from Global Ozone Monitoring Experiment satellite image sequences. *J. Geophys. Res. Atmos.*, 106, 5493-5505, <https://doi.org/10.1029/2000JD900572>

Liu, F.; Beirle, S.; Zhang, Q.; Dörner, S.; He, K. & Wagner, T. 2016. NO_x lifetimes and emissions of cities and power plants in polluted background estimated by satellite observations. *Atmos. Chem. Phys.*, 16, 5283-5298, doi:10.5194/acp-16-5283-2016

Lu, X., Jiang, H. Zhang, X., Liu, J. Zhang, Z., Jin, J., Wang, Y, Xu, J., Cheng, M. 2013. Estimated global nitrogen deposition using NO₂ column density. *Int. J. of Remote Sensing*. 34 (24), 8893-8906, <https://doi.org/10.1080/01431161.2013.853894>

Lu, Z., Streets, D. G., de Foy, B., Lamsal, L. N., Duncan, B. N., Xing, J. 2015. Emissions of nitrogen oxides from US urban areas: estimation from Ozone Monitoring Instrument retrievals for 2005–2014. *Atmos. Chem. Phys.*, 15, 10367–10383, doi:10.5194/acp-15-10367-2015

Luo, M., Shephard, M.W., Cady-Pereira, K.E., Henze, D.K., Zhu, L., Bash, J.O., Pinder, R.W., Capps, S.L., Walker, J.T., Jones, M. R. 2015. Satellite observations of tropospheric ammonia and comparisons to model simulations. *Atmospheric Environment*, 106, 262-277, <http://dx.doi.org/10.1016/j.atmosenv.2015.02.007>

Martin, R.V., Jacob, D.J., Chance, K., Kurosu, T.P., Palmer, P.I., Evans, M.J. 2003. Global inventory of nitrogen oxide emissions constrained by space-based observations of NO₂ columns. *J. Geophys. Res.* 108, 4537, doi:10.1029/2003JD003453

Martin, R., 2008. Satellite remote sensing of surface air quality. *Atmos. Environ.* 42, 7823-7843, <http://dx.doi.org/10.1016/j.atmosenv.2008.07.018>

Nowlan, C. R., Martin, R. V., Philip, S., Lamsal, L. N., Krotkov, N. A., Marais, E. A., Wang, S., Zhang, Q. 2014. Global dry deposition of nitrogen dioxide and sulfur dioxide inferred from space-based measurements. *Global Biogeochem. Cycles*, 28, 1025–1043, <https://doi.org/10.1002/2014GB004805>

Pinder, R.W., Walker, J.T., Bash, J.O., Cady-Pereira, K.E., Henze, D.K., Luo, M., Osterman, G.B., Shephard, M.W., 2011. Quantifying spatial and seasonal variability in atmospheric ammonia with in situ and space-based observations. *Geophys. Res. Lett.* 38 (4), <http://dx.doi.org/10.1029/2010GL046146>

Richter, A. Burrows, J.P. 2002. Retrieval of Tropospheric NO₂ from GOME Measurements, *Adv. Space Res.*, 29 (11), 1673-1683.

Schiferl, L.D., Heald, C.L., Van Damme, M., Clarisse, L., Clerbaux, C., Coheur, P., Nowak, J.B., Neuman, J.A., Herndon, S.C., Roscioli, J.R., Eilerman, S.J. 2016. Interannual Variability of Ammonia Concentrations over the United States: Sources and Implications. *Atmos. Chem. Phys.*, 16, 1230-12328, <https://doi.org/10.5194/acp-16-12305-2016>

Shephard, M.W., Cady-Pereira, K.E., Luo, M., Henze, D.K., Pinder, R.W., Walker, J.T., Rinsland, C.P., Bash, J.O., Zhu, L., Payne, V.H., Clarisse, L. 2011. TES ammonia retrieval strategy and global observations of the spatial and seasonal variability of ammonia. *Atmos. Chem. Phys.* 11 (20), 10743-10763, <http://dx.doi.org/10.5194/acp-11-10743-2011>

Shephard, M.W., Kharol, S.K., McLinden, C., Sioris, C.E., Cady-Pereira, K., Damers, E., Siemons, J.J., Zhang, L., Whaley, C., Zhang, J., Segers, A., Schaap, M., O'Brien, J.M., Makar, P.A., Vet, R. 2018, January. Initial Applications of the New Cross-Track Infrared Sounder (CrIS) Satellite Observations of Ammonia. Platform presentation at the meeting of American Meteorological Society, Austin, TX.

Shephard, M. W., Cady-Pereira, K.E. 2015. Cross-track Infrared Sounder (CrIS) satellite observations of tropospheric ammonia, *Atmos. Meas. Tech.*, 8, 1323-1336, <https://doi.org/10.5194/amt-8-1323-2015>

Streets, D.G., Canty, T., Carmichael, G.R., de Foy, B., Dickerson, R.R., Duncan, B.N., Edwards, D.P., Haynes, J.A., Henze, D.K., Houyoux, M.R., Jacob, D.J., Krotkov, N.A., Lamsal, L.K., Liu, Y., Lu, Z., Martin, R., Pfister, G.G., Pinder, R.W., Salawitch, R.J., Wecht, K.J. 2013. Emissions estimation from satellite retrievals: a review of current capability. *Atmos. Environ.* 77, 1011-1042.

Tong, D.Q., Lamsal, L., Pan, L., Ding, C., Kim, H., Lee, P., Chai, T., Pickering, K.E., Stajner, I. 2015. Long-term NO_x trends over large cities in the United States during the great recession: Comparison of satellite retrievals, ground observations, and emission inventories. *Atmospheric Environment*, 107, 70-84.

Valin, L. C., Russell, A. R., Cohen, R. C. 2013. Variations of OH radical in an urban plume inferred from NO₂ column measurements. *Geophys. Res. Lett.*, 40, 1856–1860, doi:10.1002/grl.50267

Velders, G. J. M., Granier, C., Portmann, R. W., Pfeilsticker, K., Wenig, M., Wagner, T., Platt, U., Richter, A., Burrows, J. P. 2001. Global tropospheric NO₂ column distributions: Comparing 3-D model calculations with GOME measurements, *J. Geophys. Res.*, 106, 12643 – 12660.

Vet, R., Artz, R. S., Carou, S., Shaw, M., Ro, C.U., Aas, W., Baker, A., Bowersox, V.C., Dentener, F., Galy-Lacaux, C., Hou, A., Pienaar, J.J., Gillett, R., Forti, M.C., Gromov, S., Hara, H., Khodzher, T., Mahowald, N.M., Nickovic, S., Rao, P.S.P., Reid, N.W. 2014. A global assessment of precipitation chemistry and deposition of sulfur, nitrogen, sea salt, base cations, organic acids, acidity and pH, and phosphorus. *Atmospheric Environment* 93, 3–100.

von Bobruzki, K., Braban, C. F., Famulari, D., Jones, S. K., Blackall, T., Smith, T. E. L., Blom, M., Coe, H., Gallagher, M., Ghalaieny, M., McGillen, M. R., Percival, C. J., Whitehead, J. D., Ellis, R., Murphy, J., Mohacsi, A., Pogany, A., Junninen, H., Rantanen, S., Sutton, M. A., Nemitz, E. 2010. Field inter-comparison of eleven atmospheric ammonia measurement techniques, *Atmos. Meas. Tech.*, 3(1), 91–112, doi:10.5194/amt-3-91-2010

Wang L., Jang, C., Zhang, Y., Wang, K., Zhang, Q., Streets, D., Fu, J., Lei, Y., Schreifels, J., He, K., Hao, J., Lam, Y-F., Lin, J., Meskhidze, N., Voorhees, S., Evaris, D., Phillips, S. 2010. Assessment of air quality benefits from national air pollution control policies in China. Part II: Evaluation of air quality predictions and air quality benefits assessment. *Atmos. Environ.* 44, 3449-3457.

Warner J.X., Wei Z., Strow L.L., Dickerson R.R., Nowak, J.B. 2016. The global tropospheric ammonia distribution as seen in the 13-year AIRS measurement record. *Atmos. Chem. Phys.* 16, 5467-5479.

Warner J.X., Dickerson R.R., Wei Z, Strow L.L., Wang Y., Liang Q. 2017. Increased atmospheric ammonia over the world's major agricultural areas detected from space. *Geophys. Res. Lett.*, 44, doi:10.1002/2016GL072305

Walker, J.M., Philip, S., Martin, R.V., Seinfeld, J.H. 2012. Simulation of nitrate, sulfate, and ammonium aerosols over the United States, *Atmos. Chem. Phys.*, 12(22), 11213–11227. doi:10.5194/acp-12-11213-2012

Wesely, M.L., Hicks, B.B. 2000. A review of the current status of knowledge on dry deposition. *Atmos. Environ.*, 34, 2261-2282, [https://doi.org/10.1016/S1352-2310\(99\)00467-7](https://doi.org/10.1016/S1352-2310(99)00467-7)

Whaley, C.H., Makar, P.A., Shephard, M.W., Zhang, L., Zhang, J., Zheng, Q., Akingunola, A., Wentworth, G.W., Murphy, J.G., Kharol, S.K., Cady-Pereira, K.E. 2018. Contributions of natural

and anthropogenic sources to ambient ammonia in the Athabasca Oil Sands and north-western Canada. *Atmos. Chem. Phys.*, 18, 2011-2034, <https://doi.org/10.5194/acp-18-2011-2018>

Whitburn, S., Van Damme, M., Kaiser, J. W., van der Werf, G.R., Turquety, S., Hurtmans, D., Clarisse, L., Clerbaux, C., Coheur, P.-F. 2015. Ammonia emissions in tropical biomass burning regions: Comparison between satellite-derived emissions and bottom-up fire inventories, *Atmos. Environ.*, 121, 42–54, <https://doi.org/10.1016/j.atmosenv.2015.03.015>

Zhang, Y., Wang, T.J., Hu, Z.Y., Xu, C.K. 2004. Temporal Variety and Spatial Distribution of Dry Deposition Velocities of Typical Air Pollutants Over Different Landuse Types. *Climatic and Environmental Research* 9, 591–604.

Zhu, L., Henze, D.K., Cady-Pereira, K.E., Shephard, M. W., Luo, M., Pinder, R.W., Bash, J.O., Jeong, G.-R. 2013. Constraining U.S. ammonia emissions using TES remote sensing observations and the GEOS-Chem adjoint model, *J. Geophys. Res. Atmos.*, 118, 3355–3368, [doi:10.1002/jgrd.50166](https://doi.org/10.1002/jgrd.50166)

Zoogman, P., Liu, X., Suleiman, R.M., Pennington, W.F., Flittner, D.E., Al-Saadi, J.A., Hilton, B.B., Nicks, D.K., Newchurch, M.J., Carr, J.L., Janz, S.J., Andraschko, M.R., Arola, A., Baker, B.D., Canova, B.P., Chan Miller, C., Cohen, R.C., Davis, J.E., Dussault, M.E., Edwards, D.P., Fishman, J., Ghulam, A., González Abad, R.M., Grutter, M., Herman, J.R., Houck J., Jacob, D.J., Joiner, J., Kerridge, B.J., Kim, J., Krotkov, N.A., Lamsal, L., Li, C., Lindfors, A., Martin, R.V., McElroy, C.T., McLinden, C., Natraj, V., Neil, D.O., Nowlan, C.R., O’Sullivan, E.J., Palmer, P.I., Pierce, R.B., Pippin, M.R., Saiz-Lopez, A., Spurr, R.J.D., Szykman, J.J., Torres, O., Veefkind, J.P., Veihelmann, B., Wang, H., Wang, J., Chance, K. 2017. Tropospheric emissions: Monitoring of pollution (TEMPO). *J of Quantitative Spectroscopy and Radiative Transfer*. 186, 17-39, <https://doi.org/10.1016/j.jqsrt.2016.05.008>

3.1.2.3. Linking of air concentrations to deposition via transference ratios

Richard Scheffe

U.S. Environmental Protection Agency, Office of Air Quality Planning and Standards, Durham, NC

Research topic summary

Transference ratios (T-ratios) were developed by EPA in 2011 as a means to directly link ambient air concentrations of pollutants subject to regulation to adverse ecosystem effects (i.e. acidification, eutrophication) driven by deposition of those pollutants. This is a necessary component of the NAAQS development and implementation process which relies on observed ambient concentrations. The T-ratio is the total deposition (including dry and wet) of a species over a specified time and area divided by the average ambient concentration of that species over that same area and time period.

There are two key knowledge gaps associated with T-ratios, the first is the need for research that explores the conceptual basis and characterizes sensitivity and uncertainty of T-ratios especially between different modeling methodologies and different spatial and temporal scales. Previous studies (Koo et al., 2015) indicated some unexplained variability in T-ratios across modeling platforms. This needs further investigation as the metric is designed for inherent buffering that should modulate differences and should not have significant variability. The metric needs to be demonstrated as robust in order to be incorporated into regulatory efforts. Therefore, this issue is a high-priority in the near-term. Cross-agency collaborations could facilitate greater coordination of existing monitoring infrastructure and modeling evaluation between NPS (CAMx), EPA (CMAQ), and ECCO (GEM-MACH).

A second knowledge gap is for research focused on the development of new transference metrics for reduced forms of nitrogen (NH_x = gaseous ammonia (NH_3) + particulate ammonium (NH_4^+)) compounds and fitting that framework with available observations. This will supplement the existing NO_y and SO_x T-ratios and help to assess the roles of NH_4^+ and NH_3 being considered in the current NO_x/SO_x review. This issue is secondary after the first knowledge gap and will likely be met in the long-term.

Introduction

Linking ambient concentrations to deposition driven adverse ecosystem effects such as aquatic acidification and eutrophication is a necessary component of the NAAQS development and implementation process, which relies on observed ambient concentrations. Deposition drives

most of the adverse ecosystem effects being considered in the current NOx/SOx review. However, the “Ambient” in NAAQS creates the need to link deposition driven impacts to ambient concentrations. T-ratios were developed by EPA in 2011 as a means to directly link ambient air concentrations of pollutants subject to regulation to adverse ecosystem effects driven by deposition of those pollutants. Those adverse ecosystem effects (e.g. aquatic acidification and eutrophication) are the observable impact of the elevated air concentrations.

The T-ratio is the ratio of total (i.e. wet plus dry) deposition of a species over a specified time and area to the average ambient concentration of that species over that same area and time period.

$$T_{i,j,t} = \frac{Dep(i)_{j,t}}{[i]_{j,t}} \quad (1)$$

where $T_{i,j,t}$ is the transference ratio for species i , for a given area, j , and a given time, t , $Dep(i)_{j,t}$ is the total (i.e. wet plus dry) deposition of species i over area j and time t , and $[i]_{j,t}$ is the averaged concentration of species i over area j and time t .

The ratios are intended to be “sufficiently stable” with respect to area, location, time, and changing environmental conditions. Studies have found that much of the variability in T-ratios is associated with the “wet” portion of concentrations (Sickles and Shadwick, 2013a). Not surprisingly, T-ratios have decreasing variability with longer averaging periods from weekly to seasonal to annual.

Ambient S- and N-containing pollutants include gases such as SO₂, NH₃, various nitrogen oxides (NO, NO₂, HONO, N₂O₅), HNO₃, and organic nitrates such as PAN; as well as particulate species such as SO₄²⁻, NO₃⁻, and NH₄⁺. The species regulated by the SOx/NOx standard will include the S-containing species and NOy listed above; NH₃ and NH₄⁺ are not currently included as regulated pollutants.

Aggregation issues

A major issue to consider is that the spatial, temporal, and chemical resolutions of the deposition data need to be on the same scale as those for the air quality standards. As an example, critical loads used to assess deposition typical on an annual scale, the annual average concentration would be needed to derive annual *T-ratios*.

State of the science

The NO_y and SO_x T-ratios developed for the Aquatic Acidification Index (AAI; Scheffe et al., 2014) are aggregated deposition velocities of all NO_y and SO_x (SO₂ and SO₄²⁻) species. Inclusion of dry and wet deposition phases enables calculation of an ambient concentration associated with a target deposition value. Sickles and Shadwick (2013a,b) published two papers evaluating T-ratios from CASTNET observations (2013a) and a series of CMAQ simulations (2013b). The first observation based study developed T-ratios from CASTNET observations, using the CASTNET dry deposition model and NADP data to estimate dry and wet deposition. CASTNET observations do not include significant components of the ambient NO_y budget such as NO₂, although the included total nitrate observations represent most of the NO_y dry deposition budget and should not affect variability analyses. Key findings from the study illustrated relative greater uncertainty in T-ratios associated with wet deposition and decreasing variability as averaging periods increased from weekly through seasonal to annual scales. Annual coefficients of variation (CVs) for T-ratios at specific monitoring sites ranged from 10-15%, which was roughly half the variability associated with total deposition. Less variability was associated with SO_x T-ratios relative to NO_y T-ratios. This decreased variability associated with annual averaging supports the use of these ratios for a standard based on annual averaging, or greater, periods as formulated in applying the AAI in the previous review. In addition to relative minor temporal annual variability, Sickles and Shadwick did not report any discernible trend in T-ratios over the 15-year CASTNET data base; another important implication from a regulatory perspective as T-ratios developed from current conditions would be applied in future year scenarios.

The modeling study (Sickles and Shadwick, 2013a) based on 2002 – 2006 CMAQ results compared observed and model estimated T-ratios and addressed spatial variability of T-ratios. Annual average site-specific T-ratios exhibited a wide range of relative differences with mean differences of 34% and 2% for TSO_x and TNO_y, respectively. Modeled T-ratios exhibited spatial variability of 13% – 22% and 24% – 36%, across grid cells within 5 subregions. Temporal variability across the five calendar years ranged from 6% - 10% and 3% - 6%, for T-SO_x and TNO_y, respectively. More importantly, no discernable temporal trends in T-ratios appeared again reinforcing the concept that T-ratios are an attribute of a particular system. The subregion analyses explored the representativeness of grid cell specific T-ratios relative to the subregion average of T-ratios, to assist in interpreting representativeness of ambient observations. Their findings indicated that taking ratios of subregion-wide deposition to cell-specific deposition substantially reduced the spatial variability that would be imparted by applying cell-specific T-ratios to a subregion. Consequently, greater confidence would result in the association of fixed monitored concentrations to subregion wide deposition estimates.

Koo et al. (2015) analyzed T-ratios produced by CMAQ and CAMx for calendar years 2005 and 2014. Their key findings indicated that CMAQ yielded significantly greater T-ratios for SO_x. T-ratio comparisons between 2005 and 2014 for both platforms exhibited very minor differences, consistent with findings discussed above.

Future research

Additional research into T-ratios is needed in two areas: (1) characterizing the relative uncertainty and sensitivity of T-ratios over spatial and temporal scales and across modeling platforms, and (2) development of new structures that accommodate reduced nitrogen (NH_x) species.

Sensitivity studies

T-ratios show promise as a regulatory tool for being largely invariant with respect to emission changes, which is consistent with the concept of an aggregated deposition velocity as there is no mechanistic association between emissions and a specific species deposition velocity. This temporal stability is a necessary constraint in a regulatory framework that would use a current T-ratio to estimate future air quality. However, the aggregation of several species then brings in potential effects of how changing emissions might influence an aggregated deposition velocity by imparting a significant shift in ambient speciation profiles which would alter the ratio of “aggregated” concentration to deposition. For example, if NO_y concentrations remain unchanged, but less NO_z (NO_z = NO_y – NO_x) is generated over time, implying more relative abundance of slow depositing NO₂, then a T-ratio for NO_y would change over time. So, indeed, T-ratios need to be thought of not only as an attribute of surface and meteorological conditions, but also atmospheric composition. Consequently, a broad range of emission perturbations (e.g., a matrix of across-the-board cuts in NO_x, SO_x and NH₃) is recommended to examine T-ratio sensitivity to emissions. Also, continued exploration into the influence of spatial aggregation on T-ratios is needed to align T-ratios with areas of consideration being explored in the NO_x/SO_x REA (e.g., ecoregion and wilderness are demarcations) and in potential implementation of a standard. This latter need would explore the alignment between representativeness of monitoring sites and spatial extent of T-ratios.

T-ratios rely on modeled estimates, raising concerns about T-ratio differences across model platforms, demonstrated by Koo et al. (2015) and the first NO_x/SO_x review. During the last review, we reasoned that a T-ratio can be generated nationally to avoid complications from different modeling platforms. Perhaps more important is understanding why different modeling platforms generate significant differences in T-ratios. This aspect is particularly troubling as the variability in a ratio metric has inherent buffering that should modulate differences.

Alternative forms of T-ratios

The explicit inclusion of NH₄⁺ as a component of PM_{2.5} expands the number of atmospheric species to be incorporated into T-ratios; hence, it is conceivable that a lumped NH_x + NO_y T-ratio (or NH₄⁺ + NO_y), for example, be generated. Regardless of the species that are

represented by T-ratios, further exploration of T-ratios for NH_x is needed for two reasons. First, there are constraints on available observations. For example, a T-ratio for NO_y assumed the availability of NO_y observations. Accurate and reliable routinely measured NO_y remains a difficult task for states, local agencies, and tribes. Consider that a surrogate for NO_y , such as total nitrate from CASTNET filter packs, which is an available and reliable measurement typically reflecting a large fraction of NO_y deposition, may be a more practical approach. Also, T-ratios for reduced forms of N_r could reduce the sensitivity of T-ratios to a changing atmosphere.

Long-term needs

Sickles and Shadwick(2013a) initiated evaluation of T-ratios using available observations. Those initial efforts could be updated with new data sets and approaches generated for potential new T-ratio structures.

References

Koo, B., Kumar, N., Knipping, E., Nopmongcol, U., Sakulyanontvittaya, T., Odman, M., Russell, A., Yarwood, G. 2015. Chemical transport model consistency in simulating regulatory outcomes and the relationship to model performance. *Atmospheric Environment*, 116. 10.1016/j.atmosenv.2015.06.036.

Scheffe, R.D., Lynch, J., Reff, A, Kelly, J.T., Hubbell, B., Greaver, T.L., Smith, J.T. 2014. The Aquatic Acidification Index: A New Regulatory Metric Linking Atmospheric and Biogeochemical Models to Assess Potential Aquatic Ecosystem Recovery. *Water Air Soil Pollution*, 225, 1838.

Sickles, J., & Shadwick, D. 2013(a). Transference ratios to predict total oxidized sulfur and nitrogen deposition part I, monitoring results. *Atmospheric Environment*, 77, 1060-1069.

Sickles, J., & Shadwick, D. Kilaru, V., Appel, K. W. 2013(b). Transference ratios to predict total oxidized sulfur and nitrogen deposition part II, modelling results. *Atmospheric Environment*, 77, 1070-1082.

3.1.2.4. Low-cost method for routine monitoring of air-surface exchange of Nr compounds

John T. Walker and Ryan Daly

U.S. EPA, Office of Research and Development, Durham, NC

Research topic summary

Cost and labor intensity of continuous high time-resolution measurements of air-surface exchange of Nr compounds make long-term concurrent studies at multiple sites impractical. Low-cost methods for directly measuring dry deposition in a routine monitoring mode are needed to more fully characterize temporal and spatial patterns of deposition across the U.S. The COTAG is a potential option that has been used in Europe (Famulari et al., 2010).

Application of this method in the U.S. would require further evaluation of the COTAG approach under representative meteorology, atmospheric chemistry and surface characteristics, some of which can be accomplished in the short term while others represent long-term research needs. Several aspects of system performance, flux uncertainty and suitability of the method for specific sites can be assessed in the short term using existing datasets such as turbulence and heat flux data from the Ameriflux network and concentration data from the CASTNET and AMoN networks. Expansion of the established time-integrated denuder/filter pack sampling methods beyond HNO_3 , NH_3 , NO_3^- , and NH_4^+ to include other gas phase Nr species such as NO_2 and PAN, as well as organic particulate species could also be explored in the near term. Long-term research efforts would include evaluation of the method over tall vegetation and direct comparison to direct chemical flux measurements with traditional higher time resolution micrometeorological methods. Ultimate deployment of the system at select sites within existing national monitoring infrastructure is also a long-term goal.

Introduction

Dry deposition processes contribute significantly to Nr deposition budgets in many areas. Direct measurements of dry deposition are needed to develop accurate deposition budgets and to characterize the relationships between meteorology, surface conditions, and air-surface exchange. However, because of the high costs, technical complexity, and labor intensity of direct flux measurements, the temporal and spatial patterns of dry deposition remain poorly characterized. This is especially significant when dry deposition estimates are coupled with wet deposition data. There is a need for large scale monitoring and assessment of dry deposition. At present, this need is addressed by using flux estimates derived from inferential models

driven by measurements of air concentrations, meteorology, and site characteristics. This approach typically employs relatively low-cost measurements of air concentrations to use in the inferential models. These include determination of inorganic Nr species by filter pack (Clarke et al., 1997), denuder (Tang et al., 2009), or passive sampler (Adon et al., 2013; Pan et al., 2012) integrated over periods ranging from one week to one month. Additionally, satellite observations have been recently used to estimate air concentrations with improved spatial resolution for use in dry deposition modeling (Jia et al., 2016). Measured air concentrations are then used within multi-layer (Meyers et al., 1998), bidirectional (Li et al., 2016) or variants of “big-leaf” (Zhang et al., 2003) type inferential models, or applied to ‘land use specific’ deposition velocities (Jia et al., 2016), to estimate gaseous and particulate fluxes at the hourly time scale. Hourly fluxes are then aggregated to seasonal and annual budgets. The inferential modeling approach is attractive because the air concentration measurements on which the method is based are sufficiently accurate and may be collected within a routine monitoring framework. However, the inferential models used to estimate fluxes contain considerable uncertainty, specifically in the parameterizations of atmospheric and surface resistances as well as compensation points (e.g., NH_3). For this reason, the dry component of Nr deposition budgets is much more uncertain than wet deposition.

Direct measurements of speciated Nr dry deposition employ continuous measurements of air concentrations within a micrometeorological flux measurement framework. The EC approach may be used for compounds that can be measured at high frequency (~ 10 Hz), which is now the case for a number of Nr compounds or groups of Nr compounds including HNO_3 (Nguyen et al., 2015), total NO_y (Geddes et al., 2014), gas phase organic Nr (Farmer et al., 2006; Wolfe et al., 2009), total Nr (Marx et al., 2012), and inorganic particles (Farmer et al., 2011; Nemitz et al., 2008). Where sensor time response is > 1 Hz, as is the case for NH_3 , gradient methods (Rumsey and Walker, 2016; Wolff et al., 2010) or relaxed eddy accumulation (Hansen et al., 2015) may be used. In all cases, fluxes are typically averaged to 30 minutes or an hour, allowing examination of diurnal variability in flux rates and their relation to surface conditions. Time-resolved micrometeorological fluxes are ideal for examining processes but datasets are often limited in temporal extent (days to several weeks) due to cost, technical challenges, logistical constraints, and time needed for processing of complex datasets. For Nr, continuous measurement methods are research grade, require an experienced operator and data analyst, and range in cost from $\sim \$50\text{K}$ to $\sim \$150\text{K}$. Other methods such as static and flow through chambers (Pape et al., 2009) or surrogate surfaces (Shahin et al., 1999) are less expensive and logistically easier to deploy for longer periods of time. However, enclosure methods are not applicable to tall vegetation and may suffer from wall losses for compounds such as HNO_3 and NH_3 . Surrogate surfaces (Shahin et al., 1999) do not accurately simulate the full range of surface characteristics that influence dry deposition.

Long-term measurements of speciated Nr dry deposition are needed to reduce uncertainty in total deposition budgets, characterize temporal and spatial patterns of dry deposition at

regional to national scales, and to evaluate dry deposition models over the full range of atmospheric and surface characteristics that influence seasonal and annual deposition budgets. Ideally, a routine direct flux measurement system could be integrated into existing deposition monitoring infrastructure such as CASTNET and NADP. Such a measurement system would possess several basic features:

- low cost
- capable of measuring the primary components of the inorganic Nr budget (HNO_3 , NH_3 , NH_4^+ , NO_3^-)
- allow for unattended operation
- suitable for time-integrated sampling
- micrometeorological flux measurement principles

State of the science

Conditional time-averaged gradient approaches (Famulari et al., 2010) satisfy the above requirements. The basic principle employs the aerodynamic gradient approach to calculate air-surface exchange rates from vertical gradients of air concentration integrated over one week to one month. To avoid biases in time integrated gradients associated with diurnal patterns in atmospheric stability, gradients are “conditionally” sampled only during periods that satisfy the micrometeorological requirements of the gradient approach. For example, under very stable conditions at night, vertical gradients become large due to lack of turbulent mixing. Conversely, during the day gradients become small when surface layer turbulence is well developed. Gradients sampled continuously over several days would become biased toward large gradients observed under stable conditions, imparting a positive bias to the calculated flux. The conditional approach samples the gradient only during specified ranges of stability, thereby avoiding such biases. By using multiple channels, gradients can be measured during different stability conditions, allowing for calculation of an aggregate flux over a range of conditions representative of diurnal variability in air surface exchange processes.

The aerodynamic gradient method is an application of K-theory (Arya, 1988), in which the vertical turbulent flux (F_x) is related to the vertical concentration gradient ($\partial X/\partial z$) and its eddy diffusivity (K_x):

$$F_x = -K_x \frac{\partial X}{\partial z} \quad (1)$$

The flux of concentration can be written as (Flechard and Fowler 1998):

$$F_x = -u_* \chi_* \quad (2)$$

where u_* is friction velocity, calculated from the momentum flux measured by EC and χ_* is the concentration scale calculated as:

$$\chi_* = -k \frac{\partial \chi}{\partial \left[\ln(z - d) + \psi_H \left(\frac{z - d}{L} \right) \right]} \quad (3)$$

Here ψ_H is the integrated stability function for sensible heat (Thom, 1975), z is the measurement height, d is the displacement height, L is the Monin-Obukhov length calculated from the EC derived sensible heat flux, and k is the von Karman constant ($k = 0.41$). In this case, the vertical concentration gradient is measured at 2 or more heights above the surface and micrometeorological variables required for calculation of the flux are measured by sonic anemometer. Using a two-height configuration in which the vertical temperature gradient is also measured, the modified Bowen-ratio approach (Meyers et al., 1996), a variant of the AGM in which the eddy diffusivity for heat in equation 1 is directly calculated, is also possible. This method requires sufficient homogeneous fetch (i.e. acceptable site), well developed turbulence, and near neutral stability. Systems typically employ two stability conditions for independent sampling of the vertical gradient, near neutral and slightly unstable, and a third “off” channel for periods outside of these conditions during which air concentrations are measured but fluxes are not calculated.

Development of the conditional time-integrated gradient system has been led by the Center for Ecology and Hydrology, Edinburgh, beginning with the prototype system described by Famulari et al. (2010). Subsequent versions of the system now employ sonic anemometry for wind and turbulence measurements and gradient configurations ranging from only two heights up to five heights (Marsailidh Twigg, CEH, personal communication). This has improved on results described by Famulari et al. (2010). An example 3-channel, 2-height configuration with a duplicate measurement at each height is shown in Figure 1. COTAG systems were deployed at 14 locations in multiple countries during the NitroEurope project as part of an effort to develop a European network for reactive nitrogen fluxes, several of which remain in operation (Marsailidh Twigg, CEH, personal communication). These systems employ a low cost, low flow (0.4 Lpm) denuder and filter pack system (DELTA system, Tang et al., 2009) to measure monthly time-integrated concentrations of NH_3 , NH_4^+ , HNO_3 , NO_3^- , SO_2 , SO_4^{2-} , HCl , Cl^- , and base cations. Fluxes are therefore calculated for monthly periods. Evaluation of the systems deployed in Europe is ongoing and has to date focused primarily on SO_2 (Famulari et al., 2010) and NH_3 (Marsailidh Twigg, CEH, personal communication).

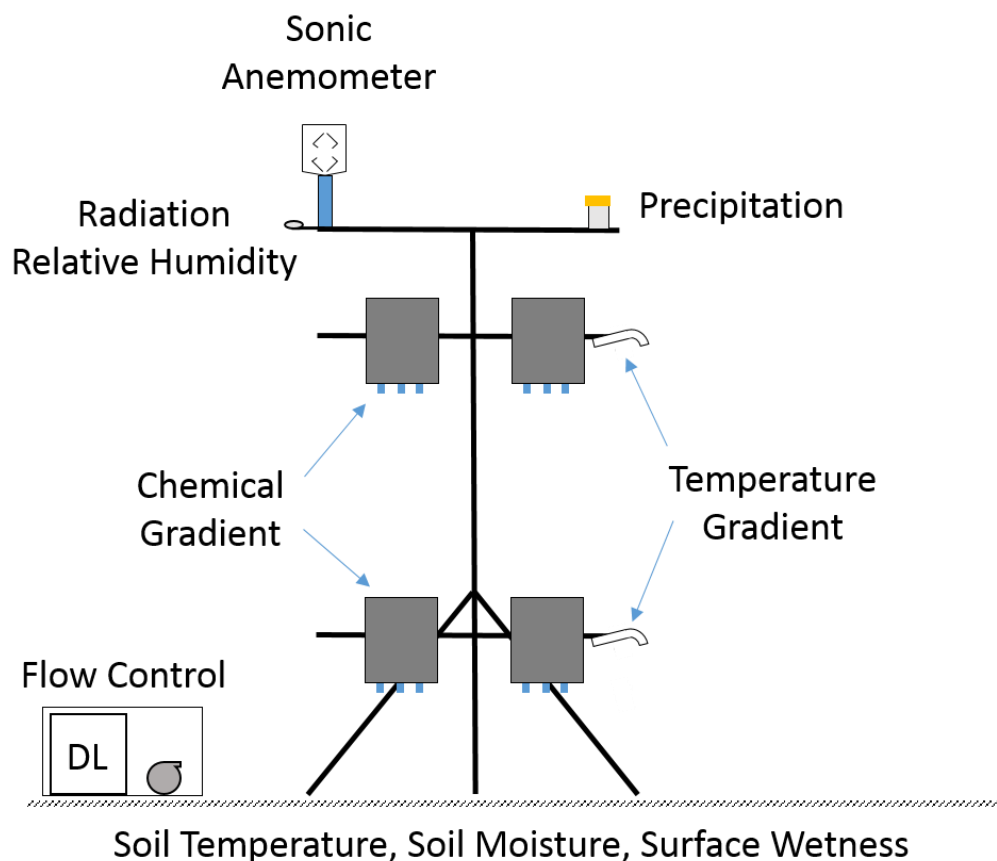

Figure 1. Schematic of a 3-channel, 2-height conditional gradient system with duplicate gradient measurements at each height.

Future research

Though more rigorous evaluation is needed, results from COTAG configurations deployed in Europe indicate that the approach is capable of resolving fluxes of SO_2 and NH_3 at a monthly time scale (Famulari et al., 2010; Marsailidh Twigg, personal communication). These likely represent the range of difficulty, from a measurement standpoint, and complexity with respect to air-surface exchange processes, to be expected for the full suite of Nr compounds. Because shorter sampling periods are fundamentally possible, such a system is potentially well suited for integration into the NADP and CASTNET infrastructure, which operate on a one-week sampling schedule. With sampling durations of one to four weeks possible, the operational protocol could be chosen to balance the need to minimize cost while ensuring that the important scales of variability in the flux process are resolved. In practice, site operators would be responsible for exchanging denuder and filter pack systems, along with standard quality assurance/quality control (QA/QC) checks of the flow control, data acquisition, and micrometeorological

equipment. Denuders and filter packs would be prepared, extracted, and analyzed by a central analytical laboratory.

Application of this method in the U.S. would require further evaluation of the COTAG approach under representative meteorology, atmospheric chemistry and surface characteristics, some of which can be accomplished in the short term while others represent long-term research needs. Several aspects of uncertainty and suitability for specific sites can be assessed in the short term using existing datasets. Because the conditional sampling approach is not appropriate for strongly stable or unstable conditions, the temporal coverage of the conditionally sampled flux will vary by site. Turbulence and heat flux data from the Ameriflux network and other existing sites could be analyzed to assess potential performance of the COTAG system in this regard and combined with concentration data from the CASTNET and AMoN networks to select the most useful and promising sites. Assessment of precision of the chemical measurements combined with existing micrometeorological measurements of transfer velocity can be used to assess expected flux detection limits for different sites. Existing flux measurement datasets can be used to assess flux uncertainty and bias associated with conditional sampling under specific conditions.

In addition to more extensive evaluation of the micrometeorological aspects of the method, expansion of the time-integrated chemical sampling methods to include additional gas phase N_r species, such as NO₂ and PAN, as well as particulate organic species would be useful. In some cases, this may be relatively straightforward. For example, filters could be analyzed for total water-soluble N. By subtracting the inorganic species, NO₃⁻ and NH₄⁺, an estimate of total water soluble organic N in particulate matter, and its deposition flux, could be calculated. Such a method evaluation, including investigation of the potential for altering sample flow rates to achieve sufficient mass collection over the desired sampling interval, could be accomplished in the short term.

Long-term research efforts would include evaluation of the method over tall vegetation and comparison to direct chemical flux measurements with traditional higher time resolution micrometeorological methods. Ultimate deployment of the system at select sites within existing national monitoring infrastructure would likely occur in a phased approach, also reflecting a longer-term goal. In summary, successful deployment of a routine direct flux measurement system would significantly improve understanding of N_r deposition budgets across the U.S.

References

Arya, S. P. 1988. Introduction to Micrometeorology, Academic Press: Cornwall, U.K.

Adon, M. et al. 2013. Dry deposition of nitrogen compounds (NO₂, HNO₃, NH₃), sulfur dioxide and ozone in west and central African ecosystems using the inferential method. *Atmos. Chem. Phys.* 13, 11351–11374.

- Clarke, J., Edgerton, E.S., Martin, B.E. 1997. Dry deposition calculations for the clean air status and trends network. *Atmos. Environ.*, 31, 3667-3678.
- Famulari, D., Fowler, D., Nemitz, E., Hargreaves, K.J., Storeton-West, R.L., Rutherford, G., Tang, Y.S., Sutton, M.A., Weston, K.J. 2010. Development of a low-cost system for measuring conditional time-averaged gradients of SO₂ and NH₃. *Environ. Mon. and Assess.*, 161, 11-27, 10.1007/s10661-008-0723-6.
- Farmer, D. K., Kimmel, J. R., Phillips, G., Docherty, K. S., Worsnop, D. R., Sueper, D., Nemitz, E., Jimenez, J.L. 2011. Eddy covariance measurements with high-resolution time-of-flight aerosol mass spectrometry: A new approach to chemically resolved aerosol fluxes. *Atmos. Meas. Tech.*, 4, 1275–1289, DOI 10.5194/amt-4-1275-2011.
- Farmer, D. K., Wooldridge, P. J., Cohen, R. C. 2006. Application of thermal-dissociation laser induced fluorescence (TD-LIF) to measurement of HNO₃, Σ alkyl nitrates, Σ peroxy nitrates, and NO₂ fluxes using eddy covariance. *Atmos. Chem. Phys.*, 6, 3471–3486, DOI 10.5194/acp-6-3471-2006.
- Flechard, C. R., Fowler, D. 1998. Atmospheric ammonia at a moorland site. I: The meteorological control of ambient ammonia concentrations and the influence of local sources. *Q. J. R. Meteor. Soc.*, 124, 733–757.
- Geddes, J.A., Murphy, J.G. 2014. Observations of reactive nitrogen oxide fluxes by eddy covariance above two mid-latitude North American mixed hardwood forests. *Atmos. Chem. Phys.*, 14, 2939-2957.
- Jia, Y., Yu, G., Gao, Y., He, N., Wang, Q., Jiao, C., and Zui, Y. 2016. Global inorganic nitrogen dry deposition inferred from ground- and space-based measurements. *Sci. Rep.*, 6, 19810; DOI 10.1038/srep19810.
- Li, Y., Schichtel, B., Walker, J.T., Schwede, D.B., Chen, X.I., Lehmann, C., Puchalski, M., Gay, D., Collett, J.L. Jr. 2016. The Increasing Importance of Deposition of Reduced Nitrogen in the United States. *P. Natl. Acad. Sci. USA*, 113, 5874–5879, DOI 10.1073/pnas.1525736113
- Meyers, T. P., Hall, M. E., Lindberg, S. E., Kim, K. 1996. Use of the modified Bowen-ratio technique to measure fluxes of trace gases. *Atmos. Environ.*, 30, 3321–3329, 1996.
- Meyers, T.P., Finkelstein, P., Clarke, J., Ellestad, T.G., Sims, P.F. 1998. A multilayer model for inferring dry deposition using standard meteorological measurements. *J. Geophys. Res.-Atmos.*, 103, 22645-22661.
- Marx, O., Brummer, C., Ammann, C., Wolff, V., Freibauer, A. 2012. TRANC - a novel fast-response converter to measure total reactive atmospheric nitrogen. *Atmos. Meas. Tech.*, 5, 1045–1057, DOI 10.5194/amt-5-1045-2012.

- Nemitz, E., Jimenez, J. L., Huffman, J. A., Ulbrich, I. M., Canagaratna, M. R., Worsnop, D. R., Guenther, A. B. 2008. An eddy covariance system for the measurement of surface/atmosphere exchange fluxes of submicron aerosol chemical species – First application above an urban area. *Aerosol Sci. Tech.*, 42, 636–657, DOI 10.1080/02786820802227352.
- Nguyen, T.B., Crounse, J.D., Teng, A.P., St. Clair, J.M., Paulot, F., Wolfe, G.M., and Wennberg, P.O. 2015. Rapid deposition of oxidized biogenic compounds to a temperate forest. *Proc. Nat. Acad. Sci. USA*, 112, E392–E401.
- Pan, Y. P., Wang, Y. S., Tang, G. Q. and Wu, D. 2012. Wet and dry deposition of atmospheric nitrogen at ten sites in Northern China. *Atmos. Chem. Phys.* 12, 6515–6535.
- Rumsey, I., Walker, J.T. 2016. Application of an online ion chromatography-based instrument for gradient flux measurements of speciated nitrogen and sulfur. *Atmos. Meas. Tech.*, 9, 2581-2592.
- Tang, Y. S. et al. 2009. European scale application of atmospheric reactive nitrogen measurements in a low-cost approach to infer dry deposition fluxes. *Agr. Ecosyst. Environ.*, 133, 183–195.
- Thom, A. S. 1975. Momentum, Mass and Heat Exchange, Academic Press: Chichester, U.K.
- Zhang, L., Brook, J.R., Vet, R. 2003. A revised parameterization for gaseous dry deposition in air-quality models. *Atmos. Chem. Phys.*, 3, 2067–2082.
- Shahin, U.M., Zhu, X., Holsen, T.M. 1999. Dry Deposition of Reduced and Reactive Nitrogen: A Surrogate Surfaces Approach. *Environ. Sci. Technol.*, 33, 2113–2117.
- Wolfe, G.M., Thornton, J.A., Yatavelli, R.L.N., McKay, M., Goldstein, A.H., LaFranchi, B., Min, K.-E., Cohen, R.C. 2009. Eddy covariance fluxes of acyl peroxy nitrates (PAN, PPN and MPAN) above a Ponderosa pine forest. *Atmos. Chem. Phys.*, 9, 615–634, DOI 10.5194/acp-9-615-2009.
- Wolff, V., Trebs, I., Ammann, C., Meixner, F.X. 2010. Aerodynamic gradient measurements of the NH_3 - HNO_3 - NH_4NO_3 triad using a wet chemical instrument: an analysis of precision requirements and flux errors. *Atmos. Meas. Tech.*, 3, 187–208, DOI 10.5194/amt-3-187-2010.

3.1.2.5 Characterization of organic nitrogen in air and precipitation

Katherine B. Benedict¹, Barkley Sive², John T. Walker³, Xi Chen⁴

¹Colorado State University, Department of Atmospheric Science, Fort Collins, CO

²National Park Service, Air Resources Division, Denver, CO

³U.S. EPA, Office of Research and Development, Durham, NC

⁴U.S. EPA, Office of Air Quality Planning and Standards, Durham, NC

Research need summary

Organic nitrogen (ON) is a complex group of individual compounds whose importance *to the total Nr budget* varies across the gas, aerosol, and aqueous (precipitation) phases, but little is known about the individual compounds, their sources and variability, deposition mechanisms and ecological impacts. The over-arching objective is the development of a comprehensive ON speciation budget, but the lack of uniformity of ON measurement methods, even for the most widely measured classes of compounds, is a critical limitation. This makes robust comparisons across studies highly challenging and limits the ability to accurately characterize ambient concentrations, and determine trends with space and time. This limits the ability to characterize ON sources and draw any conclusions regarding their importance to the atmosphere (e.g., aerosol processes) and to ecosystems (i.e., deposition).

An important scientific need is the active collaboration between the model development and monitoring communities to identify and prioritize the largest sources of uncertainty in modeled estimates of ON in conjunction with available measurement technologies. This collaboration will help strategize the approaches and design of sampling campaigns to preferentially address the largest uncertainties in ON atmospheric chemistry in a systematic way and should be achievable in the near-term. This focus is needed for this topic because of the numerous knowledge gaps in monitoring that exist. Specifics on these monitoring gaps are discussed in this topic, but a high-priority is the determination of which methods are best suited for ON speciation (gas, aerosol, precipitation; offline versus real-time) and for improving spatial and temporal coverage. This could be met in the near-term by compiling information on which techniques have been used and considering their pros and cons. The information in such a review would help identify the most widely used techniques that are good candidates for comparison studies and identify which research groups might collaborate on this project. This would be an excellent first step toward a long-term goal to standardize procedures and protocols for the most commonly used methods.

Introduction

ON is a general term for a large class of compounds containing both N and C. These compounds are present in all three phases (gas, aerosol, precipitation) and their abundance varies with time and location, depending on the strength and proximity of their sources and atmospheric processes that control their distributions. From the ecological perspective, the need to better understand ON compounds is motivated by their potential to contribute to ecosystem-altering Nr deposition. The degree to which these compounds play a role in ecosystem change is uncertain, largely because we lack a fundamental understanding of which compounds are present, what their abundances are in the atmosphere, and ultimately their rate of deposition and their bioavailability. Beyond Nr deposition related issues, increasing our understanding of ON compounds could have broader implications for air quality and atmospheric chemistry mechanisms. ON compounds can impact oxidant cycling and the oxidizing capacity of the atmosphere, thus influencing tropospheric ozone. Additionally, very little is still known about multifunctional nitrates, and these compounds could be significant in sequestering and cycling Nr (O'Brien et al., 1995). ON containing compounds can also partition into PM becoming a significant component of fine aerosol mass (Rollins et al., 2009). There are health risks associated with some classes of ON compounds such as polycyclic aromatic hydrocarbons (PAHs) and isocyanic acid (HNCO) (Cohen, 2000; Mishra et al., 2009). Nitro-PAHs have been observed in the aerosol (Marino et al., 2000) and gas phase (Nielsen et al., 1984) generally in urban areas (Marino et al., 2000; Reisen and Arey, 2005) but also in rural locations (Nielsen et al., 1984). Concentrations of nitro-PAHs in the atmosphere can change rapidly due to photochemistry and changes in the gas-particle partitioning (Feilberg et al., 1999) highlighting one aspect of the complexity in understanding atmospheric ON.

The sources of ON compounds are uncertain, but likely include both biogenic and anthropogenic sources. The importance of direct emission, biological production and photochemical processing for ON is an area of research that has not been adequately addressed and our overall knowledge of this class of compounds is rudimentary. There are several areas where research on atmospheric ON is needed to close the knowledge gaps that remain, including: (1) incomplete speciation across the gas, aerosol and precipitation phases, (2) limited spatial and temporal range, and (3) no standardized sampling or measurement protocol, particularly for particulate and aqueous samples.

Observations of organic nitrogen species

Bulk measurements

Measurement of the total (i.e., bulk) amount of ON in precipitation or aerosols is accomplished by measuring the total concentration of N and then subtracting the concentrations of the

inorganic components (NH_4^+ , NO_3^- , and NO_2^-). The first step involves converting all of the N in an aliquot of the sample to a single N compound, representing total N, by high temperature oxidation (Bronk et al., 2000), persulfate digestion or UV oxidation (Mace and Duce, 2002), or a combination persulfate digestion/UV oxidation (Walker et al., 2012). Total N, along with NH_4^+ , NO_2 , and NO_3^- in the non-converted aliquot, are then determined by colorimetry, ion chromatography, or chemiluminescence (Bronk et al., 2000; Cape et al., 2001). Online measurements of bulk ON in aerosol have been conducted using a steam jet aerosol collector (SJAC) interfaced to ion chromatography (i.e., speciated inorganics) and combustion/chemiluminescence instruments (i.e., total N). These methods resolve only the water soluble (dissolved) fraction of total N (WSTN), thus yielding a measure of total DON after subtraction of inorganic fraction.

As summarized in a review by Jickells et al. (2013), global datasets of precipitation chemistry indicate that DON contributes ~ 25% of the total N in wet deposition, on average. In the U.S., annual averages range from 2.6% to 33% (Beem et al., 2010; Benedict et al., 2013b, 2013a; Keene et al., 2002; Scudlark et al., 1998; Walker et al., 2012; Whitall and Paerl, 2001) The global average for precipitation measurements is consistent with the contribution of DON to WSTN measured in aerosols, which averages ~ 31% globally (Cape et al., 2011). In the U.S., the % contribution of DON to WSTN ranges from 3 – 33% (Benedict, 2012; Calderon et al., 2006; Calderón et al., 2007; Chen et al., 2018; Lin et al., 2010; Russell, 2003; Zamora et al., 2011; Zhang et al., 2002). In general, measurements of DON in precipitation and aerosol are limited in North America, precluding development of a complete picture of the spatial and temporal patterns of the contribution of DON to WSTN at regional to continental scales.

Speciated measurements

Gas phase

Gas phase measurements of ON compounds are by far the most comprehensive when compared to aerosol and precipitation ON species. Measurements of alkyl nitrates are commonly made as part of aircraft campaigns and ground based studies to understand their fluxes or importance in total VOCs budgets (Beine et al., 1996; Farmer and Cohen, 2008; Flocke et al., 1998; Russo et al., 2010; Simpson et al., 2002, 2003; Singh et al., 2007; Stroud et al., 2001; Thornberry et al., 2001). Peroxyacetyl nitrate, (PAN) and its homologues (peroxymethacryloyl nitrate; MPAN, peroxypropionyl nitrate; PPN) measurements are also made with some regularity due to their importance to the NO_y budget, O_3 cycling, and ability to be transported long distances in the mid-troposphere (Day et al., 2009; Fischer et al., 2011; Turnipseed et al., 2006; Zheng et al., 2011). While there are locations like Mount Bachelor in Oregon where there are multi-year records of PAN concentrations (Fischer et al., 2011), there are many more locations where there are no measurements of any organic nitrate compounds in the gas phase. Even though these organic nitrate measurements are relatively abundant, measurements of total Nr budgets suggest a missing ON component (Aneja et al., 1996; Atlas et

al., 1992; Fahey et al., 1986; Jones et al., 2011; Thornberry et al., 2001; Williams et al., 1998, 1997). More complex organic nitrate compounds like isoprene nitrates (Perring et al., 2009; Thornberry et al., 2001) and larger multi-functional nitrates may contribute to the missing NO_y, depending on the location.

The NO_y measurement itself can be problematic (Crosley, 1996; Williams et al., 1998)– the compounds that are comprised in this bulk measurement are highly temperature dependent, creating significant discrepancies between slightly different or the same technique. This creates uncertainties in comparison of NO_y across studies. In some cases it is likely that reduced ON is converted and measured as NO_y while in other cases, oxidized compounds are primarily converted (Kondo et al., 1997).

In addition to organic nitrates, other gas phase ON compounds that have been observed in the atmosphere include hydrogen cyanide (HCN), acetonitrile (CH₃CN), isocyanic acid (HNCO), and amines. HNCO, HCN, and CH₃CN are often observed in biomass burning plumes, which is considered to be their major source to the atmosphere (Ambrose et al., 2012; Roberts et al., 2011). Gas phase amines have primarily been measured in agricultural regions (Kuhn et al., 2011; Mosier et al., 1973; Schade and Crutzen, 1995) with limited measurements in other environments (Ge et al., 2011; Grönberg et al., 1992; Kallinger and Niessner, 1999; Kuwata et al., 1983; Possanzini and Dipalo, 1990) especially compared to measurements of organic nitrates.

Aerosol phase

In the aerosol phase, ON compounds include a variety of species, many of which have not been well identified. There is evidence that ON contributes a significant amount to total aerosol N (~12-33%) (Benedict, 2012; Lin et al., 2010), with higher fractions during episodic events like biomass burning (Benedict, 2012). In general, speciation measurements are focused either on amines, amino acids, urea, or other compound classes and functional groups. In submicron particles, the types of functional groups typically observed include organonitrate groups (Day et al., 2010; Nielsen et al., 1998; O'Brien et al., 1995) and amides (Cheng et al., 2006). More recent investigations into organic nitrates tend to focus on their formation from reactions of biogenic VOCs (Paulot et al., 2009; Pratt et al., 2012; Rollins et al., 2009) rather than ambient concentrations which tended to be the focus of previous work (Day et al., 2010; Nielsen et al., 1998; O'Brien et al., 1995). Observations of aerosol nitro-aromatics tend to be focused on biomass burning (Iinuma et al., 2010; Lin et al., 2016; Mohr et al., 2013; Wang et al., 2017) but they have also been observed in urban areas (Matos et al., 2017).

Laboratory studies have shown evidence of amines participating in particle formation (Malloy et al., 2009; Murphy et al., 2007; Price et al., 2016; Qiu et al., 2011); however, contributions of amines to aerosol total N have only been observed in some ambient environments.

Measurements of amines in aerosols have focused on agricultural areas (Hutchinson et al., 1982; Sorooshian et al., 2008), marine environments (Mueller et al., 2009), and some forested

locations (Samy and Hays, 2013; Sellegri et al., 2005; VandenBoer et al., 2012). Particulate amines have also been measured in samples from biomass burning plumes (Mace, 2003; Place et al., 2017). However, in many of these studies it is unclear how important amines are to total ON.

Other measurements of aerosol ON have shown evidence of water soluble ON correlating with biological emissions in marine environments (Altieri et al., 2016; Miyazaki et al., 2014). In continental locations biological sources of aerosol ON possibly include pollen and spores, yeast, and plant material as suggested in several studies (Calderon et al., 2006; Cornell et al., 2003; Milne and Zika, 1993; Scudlark et al., 1998). It is unclear if these biological sources of ON and their speciation have been measured so their importance is uncertain. In one case, Laskin et al. (2009) observed N-heterocyclic alkaloid compounds, a species naturally produced by plants and living organisms, in biomass burning aerosol.

Precipitation and atmospheric waters

Measurements of ON species in precipitation and fog water seem to be even more limited likely due to low concentrations in many environments. Some specific compounds have been identified in rain water samples including amines (Gorzelska et al., 1992; Grönberg et al., 1992), 2-nitrophenol (Leuenberger et al., 1985) and atrazine (Miller et al., 2000). While in other studies, different compound classes (Altieri et al., 2012) and functional groups were identified (Altieri et al., 2009). Altieri et al. (2012) identified elemental formulas for 5 compound classes of ON in rainwater, including classes that also contained sulfur and phosphorus in marine rainwater samples. In New Jersey, rainwater compounds with reduced N functional groups, organonitrates, and nitrooxy-organosulfates were identified (Altieri et al., 2009).

Measurement techniques for speciation

In the gas phase, there are several fairly standard methods for detection of some ON species (e.g., gas chromatography (GC), CIMS, proton-transfer-reaction mass spectrometry (PTR-MS)). However, the same standardized techniques for analysis of aerosols, filter extracts, or precipitation samples do not exist. Liquid chromatography (LC) techniques are not as well characterized as GC. Improving LC techniques that are compound specific (not just formula), do not result in significant fragmentation, and can be calibrated for N response will be needed to improve the speciation of ON in aerosol and precipitation samples. There continue to be concerns about the suitability of commonly used sampling techniques for detection of ON compounds including sampling material, sample storage and preservation, and sampling artifacts. For aerosol and precipitation detection no systematic or consistent application of sampling or speciation techniques exist, which makes it difficult to compare across studies.

Many of the sampling techniques that are used regularly for detection of VOCs also detect ON compounds. These sampling techniques are typically expensive to operate and require significant data processing. To more efficiently target ON species, an effort should be made to

determine which methods are most suited for determining ON speciation for *in situ* and offline analysis and for gaseous, aerosol, and precipitation samples.

State of the science

Techniques for measurement of bulk and speciated concentrations of ON in gas, aerosol, and precipitation are summarized in Table 1.

Bulk measurements

The description of measurement methods for bulk DON in precipitation and aerosols in the previous section generally reflects the state of the science. With respect to gas phase compounds, there are no routine methods for total ON. However, thermal dissociation has been used to measure total alkyl and peroxy nitrates in the gas phase. The technique involves the conversion of organic nitrate groups to NO₂ at different temperatures followed by detection of NO₂ by laser induced fluorescence (Day et al., 2001).

Speciated measurements

MS is currently one of the most common methods used for detection of ON species in the gas and aerosol phase. Instruments that separate the sample matrix coupled to a mass spectrometer varies by application and research interest. Both GC and PTR-MS are commonly used techniques for detection of gas phase ON species in real-time. Gas phase ON species commonly detected by GC-MS include alkyl nitrates, peroxyacyl nitrates (Koppmann, 2007). PTR-MS allows detection of species that have a higher proton-affinity than water but only mass is determined not the identity of the gas measured (de Gouw et al., 2003). CH₃CN and HCN are two species commonly measured by PTR-MS (de Gouw et al., 2003; Schneider et al., 1997). More recently online methods for detection have included CIMS which has the ability to measure inorganic N containing compounds (HNO₃, HO₂NO₂, NH₃) and organic species like PAN, PPN, MPAN, HCN, and amines [Huey, 2007]. However, the CIMS cannot easily measure all of these species simultaneously since different reagent ions are used for various species. Another application with the CIMS using negative-ion proton-transfer has been used to measure HNCO (Roberts et al., 2010).

Some of these gas phase real-time techniques can also be used for detection of ON species found in the aerosol phase or precipitation. In these techniques there is often significant sample preparation and potentially derivatization is involved (Mandalakis et al., 2011). Or a phase transition is forced like in the case of thermal-desorption PTR-MS (Timkovsky et al., 2015). Organo-nitrate compounds are commonly detected by analysis of solvent extracted filters either by GC (O'Brien et al., 1995) or FTIR (Nielsen et al., 1998). More popular for the ON speciation analysis of filter or bulk precipitation samples are LC techniques. For LC methods, compound specific analysis are often performed for amino acids (J. T. V. Matos et al., 2016), urea, amines (Place et al., 2017) or are coupled with electrospray ionization (ESI) MS for determination of ion fragments. For instance, Zhang et al. (2015) observed that 9% of the total

organic mass was N containing as identified by the ion fragment $C_3H_8N^+$. There have been some developments for LC-MS methods that are quantitative for specific compounds including amino acid (Samy et al., 2011), heterocyclic amines (Samy and Hays, 2013), catechols and nitrophenols (Desyaterik et al., 2013). In another application, Altieri et al. (2016) used ultra-high resolution ESI FT-ion cyclotron resonance (ICR)-MS to identify 750 ON compounds. They observed that ON compounds in aerosol and precipitation were distinctly different even for samples collected the same day highlighting the complexity of atmospheric ON compounds.

There are some specific analysis techniques that have been developed for certain compounds like amines, amino acids, and urea (Mace and Duce, 2002; Mandalakis et al., 2011; Namieśnik et al., 2003; Place et al., 2017; Price and Harrison, 1987). These have the added benefit of species-specific information but usually not much more. Even then, Matos et al. (2016) describes the challenges of measuring proteins and amino acids as the variety of techniques have different efficiencies of detection which makes comparison across studies difficult.

The Aerosol Mass Spectrometer has become a popular tool for online characterization of organic compounds in aerosols, including ON (Schurman et al., 2015b; Zhang et al., 2015). However, a drawback of this method is the fragmentation of compounds which results in the inability to determine specific compounds present (Schurman et al., 2015b, 2015a). Another interesting and relatively comprehensive approach to identification of aerosol ON is by 2-dimensional gas chromatography with time of flight (GCxGC-TOF)-MS and nitrogen chemiluminescence detection (Özel et al., 2011, 2010). This technique has improved sensitivity and selectivity over previous methods. Using GC methods also make the method likely to be more reproducible than LC methods; however, a drawback of this technique is the sample collection and preparation before analysis.

One of the problems in current scientific approaches is a lack of method testing or comparison of methods as shown by Timkovsky et al. (2015) who compared offline and *in situ* detection of organic compounds. They observed that negative sampling artifacts occurred for most filter samples that were collected for 2-3 days. The artifacts were potentially caused by incomplete desorption of aerosol which was particularly true for N-containing compounds. Cape et al. (2011) has a nice review of the challenges in collecting, analyzing, and comparing measurements of ON. For aerosol issues can arise in filter measurements due to substrate, storage, and whether the gaseous components are removed upstream of the filter. In the gas phase, challenges are primarily related to characterizing efficiency and removing the particle component and avoiding interferences for the particulate removal. Precipitation samples need to be carefully stored to reduce the possibility of contamination and composition change.

Table 1. Summary of measurement techniques for speciation of organic nitrogen with information compounds detected and studies that have used these techniques.

Detection	Analytical Technique	Sampling Method	Compound	Phase	Advantages	Limitations	Research groups
GC-MS							
MS	GC	offline - whole air samples	Alkyl nitrates	gas			(Jones et al., 2011)
	GC	online	hydrogen cyanide (HCN)	gas			(Ambrose et al., 2012)
	GC	offline	nitro-PAH	aerosol		complex sample extraction and cleanup	(Marino et al., 2000)
	GC-ESI	offline	free and combined amino acids	aerosol		derivatization, internal standards, concentration	(Mandalakis et al., 2011)
	GC-EI	offline	phenols	precipitation		multiple concentration steps may be necessary	(Leuenberger et al., 1985)
	GC-ion trap MS	offline	atrazine	aerosol, gas, precipitation			(Miller et al., 2000)
	GC/MS-SIM	offline	nitro-PAHs	gas			(Reisen and Arey, 2005)
CIMS							
MS	CIMS	online	HNCO	gas			(Wentzell et al., 2013)
	CIMS	online (in-situ); offline	organic nitrates	gas			(Paulot et al., 2009)
	CIMS	online	amines	gas			(Kuhn et al., 2011; Sellegri et al., 2005)
	TD-CIMS	online	PAN and homologous	gas			(Zheng et al., 2011)
	NI-PT-CIMS	online	HNCO				(Roberts et al., 2010)
	HR-CIMS-micro-orifice volatilization impactor high resolution time-of-flight	online	nitrated phenols	gas and aerosols			(Mohr et al., 2013)
	HPLC-FID-CIMS	offline	nitro-PAH	aerosol			(Nielsen et al., 1984)
LC-MS							

MS	LC-MS (ESI, TOF, QTOF, iontrap)	offline -bulk sampling, filters	nitrogen containing organic compounds including catechols, heterocyclic PAH, amines)	aerosols, fog water	many different compounds	calibration can be difficult; concentration and derivatization may be necessary	Wang et al., 2017;Desyaterik et al., 2013;Samy and Hays, 2013;Laskin et al 2009;linuma et al. 2010;Malloy et al 2009;Mueller et al., 2009
PTR-MS							
MS	PTR-MS	online	organic nitrates (hydroxy-nitrates, nitrooxy-carbonyls, nitrooxy-hydroperoxides)	gas		uncertain calibration for nitrates	Perring et al., 2009
	PTR-Linear Ion Trap-MS	online	organic nitrates	gas			Pratt et al., 2012
	HT-PTR-MS	online (in-situ); offline	2-aminoethanol				Karl et al. 2012
Other MS							
MS	ESI_FT_ICP MS	offline		precipitation	750 different compounds		Altieri et al., 2016,Altieri et al., 2012; Altieri et al., 2009
	Aerosol MS	online (in-situ); offline		aerosols		fragmentation limits speciation	Zhang et al. 2015; Day et al., 2010;Schurman et al., 2015a,b; Sorooshian et al., Malloy et al., 2009
	Ion-molecule reaction mass spectrometry	online	CH3CN, HCN	gas			Schneider et al., 1997
GC-ECD							
ECD	GC	online/offline	organic nitrates, PAN, PPN, MPAN, alkyl nitrates	gas	other VOC		Russo et al., 2010; Simpson et al., 2003; Simpson et al., 2002; Stroud et al., 2001;Fahey et al.1986; Fischer et al.2011;Thornberry et al., 2001;O'Brien et al., 1995
GC - Chemiluminescence							

Chemiluminescence	GC-N selective detector		amines	precipitation		enrichment step required	Gronberg et al. 1992
	GCxGC-	offline		aerosols	improved selectivity and sensitivity	Pre-analysis sample prep	Ozel et al., 2010; 2011
	GC-	online (in-situ)	Alkyl nitrates	gas			Flocke et al. 1998
GC-FID							
FID	GC	offline -bubblers	aliphatic amines	gas		evaporation and enrichment; derivatization required for confirmation of identification and quantification	Mosier et al., 1973; Hutchinson et al. 1982
	solid phase micro-extraction GC	offline	aliphatic amines	gas	sampling and preparation combined into one step		Namienik et al., 2003
	GC	online; offline	Alkyl nitrates	gas			Beine et al., 1996; Blake et al. 1996
FTIR							
FTIR		online	amino and amide	gas			Karl et al. 2012
		offline	organic nitrates	aerosol		function groups	Nielsen et al., 1998; Day et al., 2010
UV							
UV	HPLC		aliphatic primary and secondary amines	gas		pre-column derivatization	Kallinger and Niessner, 1999; Possanzini and Di Palo, 1990
	IC		urea	aerosol and precipitation			Mace and Duce, 2002
Fluorescence							
Thermal dissociation-laser induced fluorescence		online	total peroxy nitrates,	gas		sum of compound class	Day et al 2002; Day et al 2009; Murphy et al 2006,

			total alkylnitrates				Farmer et al, 2006,2008; Perring et al. 2009
	LC with fluorometric detector	offline	water soluble primary amino acids and aliphatic amines			Pre-column fluorescence derivatization	(Gorzelska et al., 1992)
Absorbance							
absorbance	LC-absorbance	offline	amino acids	aerosol		derivatization required	(Mace, 2003)
Other							
NMR	NMR	offline		aerosol	many different compounds		(Matos et al., 2017)
Conductivity	IC	online/offline	amines	aerosol			(Kuhn et al., 2011; Place et al., 2017; Sorooshian et al., 2008; VandenBoer et al., 2012)
Bulk ON							
	UV or persulfate oxidation	offline		aerosol; precipitation			(Calderon et al., 2006; Scudlark et al., 1998)
	high temperature oxidation	offline-filter; bulk sampling		precipitation			(Altieri et al., 2016; Miyazaki et al., 2014)
		online - Steam Jet Aerosol Collector	Bulk ON	aerosol			(Lin et al., 2010)
Reviews							
(Cornell, 2011)		"Atmospheric Nitrogen Deposition: revisiting the question of the importance of the organic component"					
(Jickells et al., 2013)		"The cycling of organic nitrogen through the atmosphere"					
(Matos et al., 2016)		review of amino acid measurements in aerosol					
(Price and Harrison, 1987)		comparison of methods for urea detection					
(Williams et al., 1998)		comparison of NOy measurement techniques					

NI: negative ion

SIM: selective ion monitoring

NCD: nitrogen chemiluminescence detection

EI: Electron Impact

ESI: Electrospray Ionization

Future research

Significant gaps remain in our understanding of ON in the atmosphere. More systematic and increased measurements of ON across atmospheric chemical conditions and spatiotemporal scales using standardized techniques are needed. This will include routine measurements of bulk organic Nr (e.g., precipitation and aerosol) to help close the total Nr deposition budget and characterize spatial and temporal patterns at the regional to continental scale, as well as speciated measurements of organic compounds to understand their relative contribution to total organic Nr, identify sources, and characterize atmospheric processes.

The chemical complexity and diverse speciation of ON leads to limitations in the development of robust sampling methods that can simultaneously provide a wealth of information on all compounds. The implication is that a complete understanding of ON speciation will need to be achieved in a step-wise manner. Thus, an important scientific need is the active collaboration between the model development and monitoring communities to identify and prioritize the largest sources of uncertainty in modeled estimates in conjunction with available monitoring technologies. This collaboration will help strategize the design of sampling campaigns to preferentially address the largest uncertainties in ON atmospheric chemistry in a systematic way and should be achievable in the near-term.

Routine bulk measurements

Development and testing of new analytical and measurement techniques to make more routine measurements or monitoring feasible is a near-term goal. Working within the frame of existing technology may limit our ability to measure ON in the way needed to achieve acceptable spatial and species level coverage. The most expeditious approach for expanding measurements of bulk ON in North America and to establish standard methods is to utilize existing monitoring infrastructure. Measurements of precipitation chemistry conducted by the NADP/NTN (weekly precipitation chemistry) NADP AIRMoN (daily precipitation chemistry, and CAPMoN along with aerosol measurements collected by the CASTNET (weekly filter-based PM measurements, no size cut) and CAPMoN (daily filter-based PM measurements, no size selection) provide measurements of speciated inorganic Nr (i.e., NH_4^+ and NO_3^-). Incorporation of methods for water soluble total N would facilitate determination of bulk water soluble ON in precipitation and PM. While this seems straightforward, there are significant challenges associated with sampling and analysis of bulk ON.

Difficulties in quantifying ON concentrations in precipitation, which result from generally low concentrations and instability after collection (Cape et al., 2001; Keene et al., 2002; Scudlark et al., 1998), are well documented. Walker et al. (2012) showed that bulk ON collected using standard NTN protocols at an agricultural site was approximately 40% lower than daily samples refrigerated immediately upon collection; daily samples collected using the AIRMoN protocol were approximately 10% lower. Difficulties in measuring bulk ON in aerosol by filter-based methods in a routine mode (daily or weekly integrated measurements) may be more extensive

than for precipitation. Aerosols collected on the filter surface may be converted in-situ by gases and other aerosol species. Some ON compounds such as amines (Pratt et al., 2009) suffer from volatility during sampling and storage, while other amine (Angelino et al., 2001; Malloy et al., 2009; Murphy et al., 2007) and amino compounds (Zhang and Anastasio, 2003) may undergo oxidation. Finally, as with precipitation samples, biological material originating from soil, leaf material, or aquatic sources may promote conversion from organic to inorganic Nr forms.

A long-term goal would be to incorporate routine measurements of bulk ON into NADP, CAPMoN, and CASTNET sampling and analytical protocols, focusing on methodological details in the near term. For precipitation measurements, stability of ON during sampling and storage is a priority. Additional effort is needed to develop a method suitable for collection of weekly precipitation samples to facilitate leveraging of the NTN infrastructure. Constraints include the need for a weekly sampling schedule and avoidance of biocides or other preservatives that introduce bias to the standard NTN analytes or are incompatible with NTN analytical procedures. Investigation of the stability of ON in the bag-type collectors used by CAPMoN is needed, for example by comparing bags to the standard NTN high-density polyethylene (HDPE) bucket at two to three sites with different concentrations of inorganic species and range of temperatures. Comparisons in the field could include a sample immediately refrigerated upon collection to minimize ON losses (Walker et al., 2012).

Identification of a suitable preservative could be conducted in parallel with bag testing, targeting candidates that may be most compatible with NTN analytes and analytical methods. Should a fully compatible preservative be identified, it could be used to ensure stability in the field and laboratory. Alternatively, the preservative could be added to a subsample in the laboratory to ensure stability during storage prior to analysis of total and inorganic Nr. Should weekly samples at all NTN sites prove unfeasible, a modified collector, in which the sample is refrigerated and shielded from sunlight, could be deployed at a subset of sites to maintain the weekly sampling schedule. This may be more economically feasible than implementing daily sampling at a subset of sites. For the CAPMoN protocol, field testing is needed to quantify the stability of ON in daily bag samples. Analytically, the addition of total N and NO_2^- analyses to the standard NTN procedures has been shown to be successful (Walker et al., 2012). The same method could be adopted by CAPMoN.

For PM measurements conducted under CASTNET and CAPMoN, the analytical method for total N developed for NTN (Walker et al., 2012) could be applied to provide weekly (CASTNET) and daily (CAPMoN) measurements of bulk water-soluble ON in aerosols. While measurements of total N, and therefore bulk ON, could be implemented rather easily, additional field testing would be needed to assess issues of ON stability in the field, particularly for weekly CASTNET samples. This would involve comparison of weekly integrated samples to averages of shorter term measurements (i.e., daily). Testing may also be needed to identify suitable methods for capture of volatile species liberated from the aerosol phases, analogous to the use of a backup nylon filter to capture HNO_3 from volatilized NH_4NO_3 .

Studies for new or modified methods that expand the capabilities of ON determination in the gas phase are a high priority. An example would be an improvement in the measurement of acyl peroxy nitrate compounds - those beyond PAN - along with the higher carbon number alkyl nitrates, including the multifunctional nitrates and adding the capability to more routinely measure heterocyclic amines and amides. In the aerosol phase, a possible avenue may be improving quantification of ON compounds measured by AMS and developing a way to quantify similar ON compound information for sizes above those the AMS can measure ($\sim 1 \mu\text{m}$).

Speciated measurements

In order to develop a comprehensive ON speciation budget, it will be important to increase collaboration between groups who specialize in measurements of the different phases (gas, aerosol, precipitation). Studies that look at ON speciation across phases will be crucial in identifying chemical mechanisms, the lifetime of these species, and which compounds or compound classes will be most important to focus on in future studies. Additionally focusing on the variability – diurnal, seasonal, annual – in specific compounds or compound classes may lend insight into the sources and importance of these species.

The determination of which methods are best suited for ON speciation (gas, aerosol, precipitation; offline versus real-time) is a high-priority which could be met in the near-term by compiling information on which techniques have been used and considering their pros and cons. This would help identify the most widely used techniques that are good candidates for comparison studies and identify which academic groups might be interested in a potential collaboration on this project. This would be an excellent first step in leading to standardization of procedures and protocols (long-term goal).

To address the long-term goal of standardized measurements there will need to be testing of sampling material, sample storage and preservation, and more rigorous quantification of sampling artifacts. Identifying the best practices for gas, aerosol, and precipitation sample collection, storage, and analysis for ON speciation determination will greatly improve our ability to interpret and analyze datasets. There is often a tradeoff in the information gained by using a species-specific method (limited compounds detected/confident in identity) versus a MS method (lots of formula/no species-specific information), particularly in aqueous samples. A balanced approach needs to be taken to get the most useful information on ON speciation.

Once methods have been examined to standardize measurement approaches it will be critical to design a field study to **investigate real-time and time-integrated measurements to more closely examine the tradeoffs in data coverage between these collection techniques (long-term goal)**. This would be an opportunity to *measure a complete ON budget* (gas, aerosol, and precipitation) at a specific site with collaborators who specialize in bulk ON measurements and specific classes in gas, aerosol, and precipitation. By measuring as many aspects of the ON budget as possible priorities for future measurements at high spatial coverage can be identified. This would also be a good comparison of the identified preferred standardized

techniques. A study like this would address the usefulness of adding some type of routine ON monitoring to national network sites, identify key measurements to include in future studies, and provide the most comprehensive ON budget to date. Inclusion of agencies and organizations that operate or fund monitoring sites in these collaborations is needed to align ON measurement priorities with monitoring objectives.

Importance of episodic events

Biomass burning has been recognized as a significant source of Nr to the atmosphere since the early 1990's (Crutzen and Andreae, 1990; Griffith et al., 1991). While NH₃ and NO_x may account for up to 50% of the N consumed during combustion (McMeeking et al., 2009), a variety of N-containing compounds have been observed during laboratory studies (Yokelson et al., 1996). Emissions of ON compounds are smaller yet significant, accounting for up to 8.7% of fuel N (Stockwell et al., 2015). ON compounds quantified during laboratory studies include HCN, CH₃CN, dimethylamine and ethylamine (C₂H₇N), acetamide (C₂H₅NO), triethylamine (C₃H₉N), amides (C₄H₉NO), other amines (C₄H₁₁NO), and benzonitrile (C₇H₅N) (Akagi et al., 2011; Stockwell et al., 2015).

While ON compounds have been observed under controlled laboratory conditions, atmospheric observations of ON associated with biomass burning are limited. Large enhancements of gas phase reduced Nr compounds, thought to contain organics, have been observed in smoke plumes coincident with highly elevated concentrations of biomass burning tracers (e.g., levoglucosan) and NH₃ (Benedict et al., 2017; Prenni et al., 2014). Gas phase amines have been directly measured in biomass burning plumes, coincident with the biomass burning tracer CH₃CN, in the eastern U.S. (You et al., 2014), while nitro-aromatics associated with biomass burning have been observed in the aerosol phase (Chen et al., 2018; Gaston et al., 2016).

Another compound associated with biomass burning that is likely to be of growing importance is HNCO. HNCO has only recently been measured in the ambient atmosphere (Roberts et al., 2010; Wentzell et al., 2013), and relatively little is known about its atmospheric chemistry (Roberts et al., 2014). The primary source of HNCO to the atmosphere is from pyrolysis/combustion of biomass; however, secondary sources of HNCO are also prevalent in urban and suburban areas, resulting from the photooxidation of reduced nitrogen species (Barnes et al., 2010; Karl et al., 2012; Lee and Wexler, 2013; Roberts et al., 2014). Additionally, HNCO dissociates in the physiological pH range, such that exposure levels >1 ppbv provide a direct source of HNCO and cyanate ion (NCO⁻) to humans at levels that have recognized health effects (Roberts et al., 2011). The fact that HNCO can severely impact human health at relatively low levels would indicate that effects to ecosystems are as significant. Thus, in order to understand the cycling and fate of HNCO in the atmosphere, more measurements in differing environments are greatly needed.

While field observations demonstrate that biomass burning episodes represent a significant source of site-specific temporal variability in atmospheric Nr, there remains a paucity of atmospheric observations sufficient to characterize the relative contribution of organic to total

Nr in smoke plumes and to understand the importance of biomass burning episodes to annual deposition budgets. The latter may be important in relatively remote environments where deposition rates are generally low but may increase orders of magnitude during smoke episodes. Incorporation of measurements of speciated ON into ongoing and planned (2018 – 2022) field programs investigating biomass burning, such as FASMEE – Fire and Smoke Model Evaluation Experiment (Joint Fire Sciences Program), FIREX (NOAA), FIRE-Chem (NASA), and WE-CAN (NSF) is needed. A long-term goal is to develop methods that allow for quantification of ON species that may be operated in a routine monitoring mode to allow for assessment of the impact of biomass burning within the context of long-term measurements of atmospheric chemistry.

References

- Akagi, S.K., Yokelson, R.J., Wiedinmyer, C., Alvarado, M.J., Reid, J.S., Karl, T., Crouse, J.D., Wennberg, P.O., 2011. Emission factors for open and domestic biomass burning for use in atmospheric models. *Atmos. Chem. Phys.* 11, 4039–4072. <https://doi.org/10.5194/acp-11-4039-2011>
- Altieri, K.E., Fawcett, S.E., Peters, A.J., Sigman, D.M., Hastings, M.G., 2016. Marine biogenic source of atmospheric organic nitrogen in the subtropical North Atlantic. *Proc. Natl. Acad. Sci.* 113, 925–930. <https://doi.org/10.1073/pnas.1516847113>
- Altieri, K.E., Hastings, M.G., Peters, A.J., Sigman, D.M., 2012. Molecular characterization of water soluble organic nitrogen in marine rainwater by ultra-high resolution electrospray ionization mass spectrometry. *Atmos. Chem. Phys.* 12, 3557–3571. <https://doi.org/10.5194/acp-12-3557-2012>
- Altieri, K.E., Turpin, B.J., Seitzinger, S.P., 2009. Oligomers, organosulfates, and nitrooxy organosulfates in rainwater identified by ultra-high resolution electrospray ionization FT-ICR mass spectrometry. *Atmos. Chem. Phys.* 9, 2533–2542.
- Ambrose, J.L., Zhou, Y., Haase, K., Mayne, H.R., Talbot, R., Sive, B.C., 2012. A gas chromatographic instrument for measurement of hydrogen cyanide in the lower atmosphere. *Atmos. Meas. Tech.* 5, 1229–1240. <https://doi.org/10.5194/amt-5-1229-2012>
- Aneja, V.P., Kim, D.-S., Das, M., Hartsell, B.E., 1996. Measurements and analysis of reactive nitrogen species in the rural troposphere of Southeast United States: Southern oxidant study site SONIA. *Atmos. Environ.* 30, 649–659. [https://doi.org/10.1016/1352-2310\(95\)00294-4](https://doi.org/10.1016/1352-2310(95)00294-4)
- Angelino, S., Suess, D.T., Prather, K.A., 2001. Formation of Aerosol Particles from Reactions of Secondary and Tertiary Alkylamines: Characterization by Aerosol Time-of-Flight Mass Spectrometry. *Environ. Sci. Technol.* 35, 3130–3138. <https://doi.org/10.1021/es0015444>
- Atlas, E.L., Ridley, B.A., Hubler, G., Walega, J.G., Carroll, M.A., Montzka, D.D., Huebert, B.J., Norton, R.B., Grahek, F.E., Schauffler, S., 1992. Partitioning and budget of NO_y species during

the Mauna Loa Observatory Photochemistry Experiment. *J. Geophys. Res. Atmospheres* 97, 10449–10462. <https://doi.org/10.1029/91JD01541>

Barnes, I., Solignac, G., Mellouki, A., Becker, K.H., 2010. Aspects of the Atmospheric Chemistry of Amides. *ChemPhysChem* 11, 3844–3857. <https://doi.org/10.1002/cphc.201000374>

Beem, K.B., Raja, S., Schwandner, F.M., Taylor, C., Lee, T., Sullivan, A.P., Carrico, C.M., McMeeking, G.R., Day, D., Levin, E., Hand, J., Kreidenweis, S.M., Schichtel, B., Malm, W.C., Collett, J.L., 2010. Deposition of reactive nitrogen during the Rocky Mountain Airborne Nitrogen and Sulfur (RoMANS) study. *Environ. Pollut.* 158, 862–872. <https://doi.org/10.1016/j.envpol.2009.09.023>

Beine, H.J., Jaffe, D.A., Blake, D.R., Atlas, E., Harris, J., 1996. Measurements of PAN, alkyl nitrates, ozone, and hydrocarbons during spring in interior Alaska. *J. Geophys. Res.- Atmospheres* 101, 12613–12619. <https://doi.org/10.1029/96JD00342>

Benedict, K.B., 2012. Observations of atmospheric reactive nitrogen species and nitrogen deposition in the Rocky Mountains (Thesis). Colorado State University. Libraries.

Benedict, K.B., Carrico, C.M., Kreidenweis, S.M., Schichtel, B., Malm, W.C., Collett, J.L., 2013a. A seasonal nitrogen deposition budget for Rocky Mountain National Park. *Ecol. Appl.* 23, 1156–1169. <https://doi.org/10.1890/12-1624.1>

Benedict, K.B., Chen, X., Sullivan, A.P., Li, Y., Day, D., Prenni, A.J., Levin, E.J.T., Kreidenweis, S.M., Malm, W.C., Schichtel, B.A., others, 2013b. Atmospheric concentrations and deposition of reactive nitrogen in Grand Teton National Park. *J. Geophys. Res. Atmospheres* 118, 11,875–11,887. <https://doi.org/10.1002/2013JD020394>

Benedict, K.B., Prenni, A.J., Carrico, C.M., Sullivan, A.P., Schichtel, B.A., Collett Jr., J.L., 2017. Enhanced concentrations of reactive nitrogen species in wildfire smoke. *Atmos. Environ.* 148, 8–15. <https://doi.org/10.1016/j.atmosenv.2016.10.030>

Bronk, D.A., Lomas, M.W., Glibert, P.M., Schukert, K.J., Sanderson, M.P., 2000. Total dissolved nitrogen analysis: comparisons between the persulfate,. *Mar. Chem.* 69, 163–178. [https://doi.org/10.1016/S0304-4203\(99\)00103-6](https://doi.org/10.1016/S0304-4203(99)00103-6)

Calderón, S.M., Poor, N.D., Campbell, S.W., 2007. Estimation of the particle and gas scavenging contributions to wet deposition of organic nitrogen. *Atmos. Environ.* 41, 4281–4290. <https://doi.org/10.1016/j.atmosenv.2006.06.067>

Calderon, S.M., Poor, N.D., Campbell, S.W., 2006. Investigation of the ultraviolet photolysis method for the determination of organic nitrogen in aerosol samples. *J. Air Waste Manag. Assoc.* 56, 1278–1286.

- Cape, J.N., Cornell, S.E., Jickells, T.D., Nemitz, E., 2011. Organic nitrogen in the atmosphere — Where does it come from? A review of sources and methods. *Atmospheric Res.* 102, 30–48. <https://doi.org/10.1016/j.atmosres.2011.07.009>
- Cape, J.N., Kirika, A., Rowland, A.P., Wilson, D.R., Jickells, T.D., Cornell, S., 2001. Organic Nitrogen in Precipitation: Real Problem or Sampling Artefact? *Sci. World J.* 1, 230–237. <https://doi.org/10.1100/tsw.2001.278>
- Chen, X., Xie, M., Hays, M.D., Edgerton, E., Schwede, D., Walker, J.T., 2018. Characterization of organic nitrogen in aerosols at a forest site in the southern Appalachian Mountains. *Atmos. Chem. Phys.* 18, 6829–6846. <https://doi.org/10.5194/acp-18-6829-2018>
- Cheng, Y., Li, S.-M., Leithead, A., 2006. Chemical Characteristics and Origins of Nitrogen-Containing Organic Compounds in PM_{2.5} Aerosols in the Lower Fraser Valley. *Environ. Sci. Technol.* 40, 5846–5852. <https://doi.org/10.1021/es0603857>
- Cohen, A.J., 2000. Outdoor air pollution and lung cancer. *Environ. Health Perspect.* 108, 743–750.
- Cornell, S.E., 2011. Atmospheric nitrogen deposition: Revisiting the question of the importance of the organic component. *Environ. Pollut.* 159, 2214–2222. <https://doi.org/10.1016/j.envpol.2010.11.014>
- Cornell, S.E., Jickells, T.D., Cape, J.N., Rowland, A.P., Duce, R.A., 2003. Organic nitrogen deposition on land and coastal environments: a review of methods and data. *Atmos. Environ.* 37, 2173–2191. [https://doi.org/10.1016/S1352-2310\(03\)00133-X](https://doi.org/10.1016/S1352-2310(03)00133-X)
- Crosley, D.R., 1996. NO_y Blue Ribbon panel. *J. Geophys. Res. Atmospheres* 101, 2049–2052. <https://doi.org/10.1029/95JD02276>
- Crutzen, P.J., Andreae, M.O., 1990. Biomass Burning in the Tropics: Impact on Atmospheric Chemistry and Biogeochemical Cycles. *Science* 250, 1669–1678.
- Day, D.A., Farmer, D.K., Goldstein, A.H., Wooldridge, P.J., Minejima, C., Cohen, R.C., 2009. Observations of NO_x, ΣPNs, ΣANs, and HNO₃ at a Rural Site in the California Sierra Nevada Mountains: summertime diurnal cycles. *Atmos. Chem. Phys.* 9, 4879–4896.
- Day, D.A., Liu, S., Russell, L.M., Ziemann, P.J., 2010. Organonitrate group concentrations in submicron particles with high nitrate and organic fractions in coastal southern California. *Atmos. Environ.* 44, 1970–1979. <https://doi.org/10.1016/j.atmosenv.2010.02.045>
- de Gouw, J., Warneke, C., Karl, T., Eerdekens, G., van der Veen, C., Fall, R., 2003. Sensitivity and specificity of atmospheric trace gas detection by proton-transfer-reaction mass spectrometry. *Int. J. Mass Spectrom., In Memoriam of Werner Lindinger* 223–224, 365–382. [https://doi.org/10.1016/S1387-3806\(02\)00926-0](https://doi.org/10.1016/S1387-3806(02)00926-0)

- Desyaterik, Y., Sun, Y., Shen, X., Lee, T., Wang, X., Wang, T., Collett, J.L., 2013. Speciation of “brown” carbon in cloud water impacted by agricultural biomass burning in eastern China. *J. Geophys. Res. Atmospheres* 118, 7389–7399. <https://doi.org/10.1002/jgrd.50561>
- Fahey, D.W., Hübler, G., Parrish, D.D., Williams, E.J., Norton, R.B., Ridley, B.A., Singh, H.B., Liu, S.C., Fehsenfeld, F.C., 1986. Reactive nitrogen species in the troposphere: Measurements of NO, NO₂, HNO₃, particulate nitrate, peroxyacetyl nitrate (PAN), O₃, and total reactive odd nitrogen (NO_y) at Niwot Ridge, Colorado. *J. Geophys. Res. Atmospheres* 91, 9781–9793. <https://doi.org/10.1029/JD091iD09p09781>
- Farmer, D.K., Cohen, R.C., 2008. Observations of HNO₃, ΣAN, ΣPN and NO₂ fluxes: evidence for rapid HO_x chemistry within a pine forest canopy. *Atmos. Chem. Phys.* 8, 3899–3917.
- Feilberg, A., Kamens, R.M., Strommen, M.R., Nielsen, T., 1999. Photochemistry and Partitioning of Semivolatile Nitro-PAH in the Atmosphere. *Polycycl. Aromat. Compd.* 14, 151–160. <https://doi.org/10.1080/10406639908019121>
- Fischer, E.V., Jaffe, D.A., Weatherhead, E.C., 2011. Free tropospheric peroxyacetyl nitrate (PAN) and ozone at Mount Bachelor: potential causes of variability and timescale for trend detection. *Atmos. Chem. Phys.* 11, 5641–5654. <https://doi.org/10.5194/acp-11-5641-2011>
- Flocke, F., Volz-Thomas, A., Buers, H.-J., Pätz, W., Garthe, H.-J., Kley, D., 1998. Long-term measurements of alkyl nitrates in southern Germany: 1. General behavior and seasonal and diurnal variation. *J. Geophys. Res. Atmospheres* 103, 5729–5746. <https://doi.org/10.1029/97JD03461>
- Gaston, C.J., Lopez-Hilfiker, F.D., Whybrew, L.E., Hadley, O., McNair, F., Gao, H., Jaffe, D.A., Thornton, J.A., 2016. Online molecular characterization of fine particulate matter in Port Angeles, WA: Evidence for a major impact from residential wood smoke. *Atmos. Environ.* 138, 99–107. <https://doi.org/10.1016/j.atmosenv.2016.05.013>
- Ge, X., Wexler, A.S., Clegg, S.L., 2011. Atmospheric amines – Part I. A review. *Atmos. Environ.* 45, 524–546. <https://doi.org/10.1016/j.atmosenv.2010.10.012>
- Gorzelska, K., Galloway, J., Watterson, K., Keene, W., 1992. Water-Soluble Primary Amine Compounds in Rural Continental Precipitation. *Atmos. Environ. Part -Gen. Top.* 26, 1005–1018. [https://doi.org/10.1016/0960-1686\(92\)90032-G](https://doi.org/10.1016/0960-1686(92)90032-G)
- Griffith, D.W.T., Mankin, W.G., Coffey, M.T., Ward, D.E., Riebau, A., 1991. FTIR remote sensing of biomass burning emissions of CO₂, CO, CH₄, CH₂O, NO, NO₂, NH₃ and N₂O, in: *Global Biomass Burning: Atmospheric, Climatic, and Biospheric Implications*. MIT Press, Cambridge, MA, pp. 230–239.
- Grönberg, L., Lövkvist, P., Jönsson, J., Ake, 1992. Measurement of aliphatic amines in ambient air and rainwater. *Chemosphere* 24, 1533–1540.

- Hutchinson, G.L., Mosier, A.R., Andre, C.E., 1982. Ammonia and Amine Emissions from a Large Cattle Feedlot1. *J. Environ. Qual.* 11, 288.
<https://doi.org/10.2134/jeq1982.00472425001100020028x>
- Iinuma, Y., Böge, O., Gräfe, R., Herrmann, H., 2010. Methyl-Nitrocatechols: Atmospheric Tracer Compounds for Biomass Burning Secondary Organic Aerosols. *Environ. Sci. Technol.* 44, 8453–8459. <https://doi.org/10.1021/es102938a>
- Jickells, T., Baker, A.R., Cape, J.N., Cornell, S.E., Nemitz, E., 2013. The cycling of organic nitrogen through the atmosphere. *Philos. Trans. R. Soc. B Biol. Sci.* 368, 20130115.
<https://doi.org/10.1098/rstb.2013.0115>
- Jones, A.E., Wolff, E.W., Ames, D., Bauguitte, S.J.-B., Clemitshaw, K.C., Fleming, Z., Mills, G.P., Saiz-Lopez, A., Salmon, R.A., Sturges, W.T., Worton, D.R., 2011. The multi-seasonal NO_y budget in coastal Antarctica and its link with surface snow and ice core nitrate: results from the CHABLIS campaign. *Atmos. Chem. Phys.* 11, 9271–9285. <https://doi.org/10.5194/acp-11-9271-2011>
- Kallinger, G., Niessner, R., 1999. Laboratory investigation of annular denuders as sampling system for the determination of aliphatic primary and secondary amines in stack gas. *Microchim. Acta* 130, 309–316.
- Karl, M., Dye, C., Schmidbauer, N., Wisthaler, A., Mikoviny, T., D'Anna, B., Müller, M., Borrás, E., Clemente, E., Muñoz, A., Porras, R., Ródenas, M., Vázquez, M., Brauers, T., 2012. Study of OH-initiated degradation of 2-aminoethanol. *Atmos. Chem. Phys.* 12, 1881–1901.
<https://doi.org/10.5194/acp-12-1881-2012>
- Keene, W.C., Montag, J.A., Maben, J.R., Southwell, M., Leonard, J., Church, T.M., Moody, J.L., Galloway, J.N., 2002. Organic nitrogen in precipitation over Eastern North America. *Atmos. Environ.* 36, 4529–4540.
- Kondo, Y., Kawakami, S., Koike, M., Fahey, D.W., Nakajima, H., Zhao, Y., Toriyama, N., Kanada, M., Sachse, G.W., Gregory, G.L., 1997. Performance of an aircraft instrument for the measurement of NO_y. *J. Geophys. Res. Atmospheres* 102, 28663–28671.
<https://doi.org/10.1029/96JD03819>
- Koppmann, R. (Ed.), 2007. *Volatile Organic Compounds in the Atmosphere*, 1 edition. ed. Wiley-Blackwell, Oxford; Ames, Iowa.
- Kuhn, U., Sintermann, J., Spirig, C., Jocher, M., Ammann, C., Neftel, A., 2011. Basic biogenic aerosol precursors: Agricultural source attribution of volatile amines revised. *Geophys. Res. Lett.* 38, L16811. <https://doi.org/10.1029/2011GL047958>
- Kuwata, K., Akiyama, E., Yamazaki, Y., Yamasaki, H., Kuge, Y., Kiso, Y., 1983. Trace Determination of Low-Molecular Weight Aliphatic-Amines in Air by Gas-Chromatography. *Anal. Chem.* 55, 2199–2201. <https://doi.org/10.1021/ac00263a046>

- Laskin, A., Smith, J.S., Laskin, J., 2009. Molecular Characterization of Nitrogen-Containing Organic Compounds in Biomass Burning Aerosols Using High-Resolution Mass Spectrometry. *Environ. Sci. Technol.* 43, 3764–3771. <https://doi.org/10.1021/es803456n>
- Lee, D., Wexler, A.S., 2013. Atmospheric amines – Part III: Photochemistry and toxicity. *Atmos. Environ.* 71, 95–103. <https://doi.org/10.1016/j.atmosenv.2013.01.058>
- Leuenberger, C., Ligocki, M.P., Pankow, J.F., 1985. Trace organic compounds in rain. 4. Identities, concentrations, and scavenging mechanisms for phenols in urban air and rain. *Environ. Sci. Technol.* 19, 1053–1058. <https://doi.org/10.1021/es00141a005>
- Lin, M., Walker, J., Geron, C., Khlystov, A., 2010. Organic nitrogen in PM_{2.5} aerosol at a forest site in the Southeast US. *Atmos. Chem. Phys.* 10, 2145–2157.
- Lin, P., Aiona, P.K., Li, Y., Shiraiwa, M., Laskin, J., Nizkorodov, S.A., Laskin, A., 2016. Molecular Characterization of Brown Carbon in Biomass Burning Aerosol Particles [WWW Document]. <https://doi.org/10.1021/acs.est.6b03024>
- Mace, K.A., 2003. Water-soluble organic nitrogen in Amazon Basin aerosols during the dry (biomass burning) and wet seasons. *J. Geophys. Res.* 108. <https://doi.org/10.1029/2003JD003557>
- Mace, K.A., Duce, R.A., 2002. Determination of Urea in Atmospheric Aerosols and Natural Waters - A Cation Exchange Method. *Int. J. Environ. Anal. Chem.* 82, 341–352. <https://doi.org/10.1080/0306731021000003455>
- Malloy, Q.G.J., Qi, L., Warren, B., Cocker, D.R., Erupe, M.E., Silva, P.J., 2009. Secondary organic aerosol formation from primary aliphatic amines with NO₃ radical. *Atmos. Chem. Phys.* 9, 2051–2060.
- Mandalakis, M., Apostolaki, M., Tziaras, T., Polymenakou, P., Stephanou, E.G., 2011. Free and combined amino acids in marine background atmospheric aerosols over the Eastern Mediterranean. *Atmos. Environ.* 45, 1003–1009. <https://doi.org/10.1016/j.atmosenv.2010.10.046>
- Marino, F., Cecinato, A., Siskos, P.A., 2000. Nitro-PAH in ambient particulate matter in the atmosphere of Athens. *Chemosphere* 40, 533–537. [https://doi.org/10.1016/S0045-6535\(99\)00308-2](https://doi.org/10.1016/S0045-6535(99)00308-2)
- Matos, Duarte, R.M.B.O., Duarte, A.C., 2016. Challenges in the identification and characterization of free amino acids and proteinaceous compounds in atmospheric aerosols: A critical review. *TrAC Trends Anal. Chem.* 75, 97–107. <https://doi.org/10.1016/j.trac.2015.08.004>
- Matos, J.T.V., Duarte, R.M.B.O., Duarte, A.C., 2016. Challenges in the identification and characterization of free amino acids and proteinaceous compounds in atmospheric aerosols: A critical review. *Trac-Trends Anal. Chem.* 75, 97–107. <https://doi.org/10.1016/j.trac.2015.08.004>

- Matos, J.T.V., Duarte, R.M.B.O., Lopes, S.P., Silva, A.M.S., Duarte, A.C., 2017. Persistence of urban organic aerosols composition: Decoding their structural complexity and seasonal variability. *Environ. Pollut.* 231, 281–290. <https://doi.org/10.1016/j.envpol.2017.08.022>
- McMeeking, G.R., Kreidenweis, S.M., Baker, S., Carrico, C.M., Chow, J.C., Collett, J.L., Hao, W.M., Holden, A.S., Kirchstetter, T.W., Malm, W.C., Moosmüller, H., Sullivan, A.P., Wold, C.E., 2009. Emissions of trace gases and aerosols during the open combustion of biomass in the laboratory. *J. Geophys. Res.* 114. <https://doi.org/10.1029/2009JD011836>
- Miller, S.M., Sweet, C.W., DePinto, J.V., Hornbuckle, K.C., 2000. Atrazine and Nutrients in Precipitation: Results from the Lake Michigan Mass Balance Study. *Environ. Sci. Technol.* 34, 55–61. <https://doi.org/10.1021/es990486n>
- Milne, P., Zika, R., 1993. Amino-Acid Nitrogen in Atmospheric Aerosols - Occurrence, Sources and Photochemical Modification. *J. Atmospheric Chem.* 16, 361–398. <https://doi.org/10.1007/BF01032631>
- Mishra, P., Samarth, R., Pathak, N., Jain, S., Banerjee, S., Maudar, K., 2009. Bhopal Gas Tragedy: review of clinical and experimental findings after 25 years. *Int. J. Occup. Med. Environ. Health* 22, 193–202. <https://doi.org/10.2478/v10001-009-0028-1>
- Miyazaki, Y., Fu, P., Ono, K., Tachibana, E., Kawamura, K., 2014. Seasonal cycles of water-soluble organic nitrogen aerosols in a deciduous broadleaf forest in northern Japan. *J. Geophys. Res. Atmospheres* 119, 1440–1454. <https://doi.org/10.1002/2013JD020713>
- Mohr, C., Lopez-Hilfiker, F.D., Zotter, P., Prévôt, A.S.H., Xu, L., Ng, N.L., Herndon, S.C., Williams, L.R., Franklin, J.P., Zahniser, M.S., Worsnop, D.R., Knighton, W.B., Aiken, A.C., Gorkowski, K.J., Dubey, M.K., Allan, J.D., Thornton, J.A., 2013. Contribution of Nitrated Phenols to Wood Burning Brown Carbon Light Absorption in Detling, United Kingdom during Winter Time [WWW Document]. <https://doi.org/10.1021/es400683v>
- Mosier, A., Andre, C., Viets, F., 1973. Identification of Aliphatic-Amines Volatilized from Cattle Feedyard. *Environ. Sci. Technol.* 7, 642–644. <https://doi.org/10.1021/es60079a009>
- Mueller, C., Iinuma, Y., Karstensen, J., van Pinxteren, D., Lehmann, S., Gnauk, T., Herrmann, H., 2009. Seasonal variation of aliphatic amines in marine sub-micrometer particles at the Cape Verde islands. *Atmos. Chem. Phys.* 9, 9587–9597.
- Murphy, S.M., Sorooshian, A., Kroll, J.H., Ng, N.L., Chhabra, P., Tong, C., Surratt, J.D., Knipping, E., Flagan, R.C., Seinfeld, J.H., 2007. Secondary aerosol formation from atmospheric reactions of aliphatic amines. *Atmos. Chem. Phys.* 7, 2313–2337.
- Namieśnik, J., Jastrzębska, A., Zygmunt, B., 2003. Determination of volatile aliphatic amines in air by solid-phase microextraction coupled with gas chromatography with flame ionization detection. *J. Chromatogr. A* 1016, 1–9. [https://doi.org/10.1016/S0021-9673\(03\)01296-2](https://doi.org/10.1016/S0021-9673(03)01296-2)

- Nielsen, T., Platz, J., Granby, K., Hansen, A.B., Skov, H., Egelov, A.H., 1998. Particulate organic nitrates: Sampling and night/day variation. *Atmos. Environ.* 32, 2601–2608. [https://doi.org/10.1016/S1352-2310\(97\)00483-4](https://doi.org/10.1016/S1352-2310(97)00483-4)
- Nielsen, T., Seitz, B., Ramdahl, T., 1984. Occurrence of nitro-PAH in the atmosphere in a rural area. *Atmos. Environ.* 1967 18, 2159–2165. [https://doi.org/10.1016/0004-6981\(84\)90203-8](https://doi.org/10.1016/0004-6981(84)90203-8)
- O'Brien, J., Shepson, P., Muthuramu, K., Hao, C., Niki, H., Hastie, D., Taylor, R., Roussel, P., 1995. Measurements of Alkyl and Multifunctional Organic Nitrates at a Rural Site in Ontario. *J. Geophys. Res.-Atmospheres* 100, 22795–22804. <https://doi.org/10.1029/94JD03247>
- Özel, M.Z., Hamilton, J.F., Lewis, A.C., 2011. New Sensitive and Quantitative Analysis Method for Organic Nitrogen Compounds in Urban Aerosol Samples. *Environ. Sci. Technol.* 45, 1497–1505. <https://doi.org/10.1021/es102528g>
- Özel, M.Z., Ward, M.W., Hamilton, J.F., Lewis, A.C., Raventós-Duran, T., Harrison, R.M., 2010. Analysis of Organic Nitrogen Compounds in Urban Aerosol Samples Using GCxGC-TOF/MS. *Aerosol Sci. Technol.* 44, 109–116. <https://doi.org/10.1080/02786820903410105>
- Paulot, F., Crouse, J.D., Kjaergaard, H.G., Kroll, J.H., Seinfeld, J.H., Wennberg, P.O., 2009. Isoprene photooxidation: new insights into the production of acids and organic nitrates. *Atmos. Chem. Phys.* 9, 1479–1501.
- Perring, A.E., Wisthaler, A., Graus, M., Wooldridge, P.J., Lockwood, A.L., Mielke, L.H., Shepson, P.B., Hansel, A., Cohen, R.C., 2009. A product study of the isoprene+NO₃ reaction. *Atmos. Chem. Phys.* 9, 4945–4956.
- Place, B.K., Quilty, A.T., Di Lorenzo, R.A., Ziegler, S.E., VandenBoer, T.C., 2017. Quantitation of 11 alkylamines in atmospheric samples: separating structural isomers by ion chromatography. *Atmos. Meas. Tech.* 10, 1061–1078. <https://doi.org/10.5194/amt-10-1061-2017>
- Possanzini, M., Dipalo, V., 1990. Improved Hplc Determination of Aliphatic-Amines in Air by Diffusion and Derivatization Techniques. *Chromatographia* 29, 151–154. <https://doi.org/10.1007/BF02268702>
- Pratt, K.A., Hatch, L.E., Prather, K.A., 2009. Seasonal Volatility Dependence of Ambient Particle Phase Amines. *Environ. Sci. Technol.* 43, 5276–5281. <https://doi.org/10.1021/es803189n>
- Pratt, K.A., Mielke, L.H., Shepson, P.B., Bryan, A.M., Steiner, A.L., Ortega, J., Daly, R., Helmig, D., Vogel, C.S., Griffith, S., Dusanter, S., Stevens, P.S., Alaghmand, M., 2012. Contributions of individual reactive biogenic volatile organic compounds to organic nitrates above a mixed forest. *Atmos. Chem. Phys.* 12, 10125–10143. <https://doi.org/10.5194/acp-12-10125-2012>
- Prenni, A.J., Levin, E.J.T., Benedict, K.B., Sullivan, A.P., Schurman, M.I., Gebhart, K.A., Day, D.E., Carrico, C.M., Malm, W.C., Schichtel, B.A., Collett, J.L., Kreidenweis, S.M., 2014. Gas-phase reactive nitrogen near Grand Teton National Park: Impacts of transport, anthropogenic

emissions, and biomass burning. *Atmos. Environ.* 89, 749–756.

<https://doi.org/10.1016/j.atmosenv.2014.03.017>

Price, D.J., Kacarab, M., Cocker, D.R., Purvis-Roberts, K.L., Silva, P.J., 2016. Effects of temperature on the formation of secondary organic aerosol from amine precursors. *Aerosol Sci. Technol.* 50, 1216–1226. <https://doi.org/10.1080/02786826.2016.1236182>

Price, N., Harrison, P., 1987. Comparison of Methods for the Analysis of Dissolved Urea in Seawater. *Mar. Biol.* 94, 307–317. <https://doi.org/10.1007/BF00392945>

Qiu, C., Wang, L., Lal, V., Khalizov, A.F., Zhang, R., 2011. Heterogeneous Reactions of Alkylamines with Ammonium Sulfate and Ammonium Bisulfate. *Environ. Sci. Technol.* 45, 4748–4755. <https://doi.org/10.1021/es1043112>

Reisen, F., Arey, J., 2005. Atmospheric Reactions Influence Seasonal PAH and Nitro-PAH Concentrations in the Los Angeles Basin. *Environ. Sci. Technol.* 39, 64–73. <https://doi.org/10.1021/es035454l>

Roberts, J.M., Veres, P., Warneke, C., Neuman, J.A., Washenfelder, R.A., Brown, S.S., Baasandorj, M., Burkholder, J.B., Burling, I.R., Johnson, T.J., Yokelson, R.J., de Gouw, J., 2010. Measurement of HONO, HNCO, and other inorganic acids by negative-ion proton-transfer chemical-ionization mass spectrometry (NI-PT-CIMS): application to biomass burning emissions. *Atmos. Meas. Tech.* 3, 981–990. <https://doi.org/10.5194/amt-3-981-2010>

Roberts, J.M., Veres, P.R., Cochran, A.K., Warneke, C., Burling, I.R., Yokelson, R.J., Lerner, B., Gilman, J.B., Kuster, W.C., Fall, R., Gouw, J. de, 2011. Isocyanic acid in the atmosphere and its possible link to smoke-related health effects. *Proc. Natl. Acad. Sci.* 108, 8966–8971. <https://doi.org/10.1073/pnas.1103352108>

Roberts, J.M., Veres, P.R., VandenBoer, T.C., Warneke, C., Graus, M., Williams, E.J., Lefter, B., Brock, C.A., Bahreini, R., Öztürk, F., Middlebrook, A.M., Wagner, N.L., Dubé, W.P., de Gouw, J.A., 2014. New insights into atmospheric sources and sinks of isocyanic acid, HNCO, from recent urban and regional observations. *J. Geophys. Res. Atmospheres* 119, 2013JD019931. <https://doi.org/10.1002/2013JD019931>

Rollins, A.W., Kiendler-Scharr, A., Fry, J.L., Brauers, T., Brown, S.S., Dorn, H.-P., Dube, W.P., Fuchs, H., Mensah, A., Mentel, T.F., Rohrer, F., Tillmann, R., Wegener, R., Wooldridge, P.J., Cohen, R.C., 2009. Isoprene oxidation by nitrate radical: alkyl nitrate and secondary organic aerosol yields. *Atmos. Chem. Phys.* 9, 6685–6703.

Russell, K.M., 2003. Phase partitioning and dry deposition of atmospheric nitrogen at the mid-Atlantic U.S. coast. *J. Geophys. Res.* 108. <https://doi.org/10.1029/2003JD003736>

Russo, R.S., Zhou, Y., Haase, K.B., Wingenter, O.W., Frinak, E.K., Mao, H., Talbot, R.W., Sive, B.C., 2010. Temporal variability, sources, and sinks of C1-C5 alkyl nitrates in coastal New England. *Atmos. Chem. Phys.* 10, 1865–1883. <https://doi.org/10.5194/acp-10-1865-2010>

- Samy, S., Hays, M.D., 2013. Quantitative LC–MS for water-soluble heterocyclic amines in fine aerosols (PM_{2.5}) at Duke Forest, USA. *Atmos. Environ.* 72, 77–80. <https://doi.org/10.1016/j.atmosenv.2013.02.032>
- Samy, S., Robinson, J., Hays, M.D., 2011. An advanced LC-MS (Q-TOF) technique for the detection of amino acids in atmospheric aerosols. *Anal. Bioanal. Chem.* 401, 3103–3113. <https://doi.org/10.1007/s00216-011-5238-2>
- Schade, G., Crutzen, P., 1995. Emission of Aliphatic-Amines from Animal Husbandry and Their Reactions - Potential Source of N₂O and HCN. *J. Atmospheric Chem.* 22, 319–346. <https://doi.org/10.1007/BF00696641>
- Schneider, J., Bürger, V., Arnold, F., 1997. Methyl cyanide and hydrogen cyanide measurements in the lower stratosphere: Implications for methyl cyanide sources and sinks. *J. Geophys. Res. Atmospheres* 102, 25501–25506. <https://doi.org/10.1029/97JD02364>
- Schurman, M.I., Lee, T., Desyaterik, Y., Schichtel, B.A., Kreidenweis, S.M., Collett, J.L., 2015a. Transport, biomass burning, and in-situ formation contribute to fine particle concentrations at a remote site near Grand Teton National Park. *Atmos. Environ.* 112, 257–268. <https://doi.org/10.1016/j.atmosenv.2015.04.043>
- Schurman, M.I., Lee, T., Sun, Y., Schichtel, B.A., Kreidenweis, S.M., Collett Jr., J.L., 2015b. Investigating types and sources of organic aerosol in Rocky Mountain National Park using aerosol mass spectrometry. *Atmos. Chem. Phys.* 15, 737–752. <https://doi.org/10.5194/acp-15-737-2015>
- Scudlark, J.R., Russell, K.M., Galloway, J.N., Church, T.M., Keene, W.C., 1998. Organic nitrogen in precipitation at the mid-Atlantic US coast - Methods evaluation and preliminary measurements. *Atmos. Environ.* 32, 1719–1728. [https://doi.org/10.1016/S1352-2310\(97\)00458-5](https://doi.org/10.1016/S1352-2310(97)00458-5)
- Sellegri, K., Hanke, M., Umann, B., Arnold, F., Kulmala, M., 2005. Measurements of organic gases during aerosol formation events in the boreal forest atmosphere during QUEST. *Atmos. Chem. Phys.* 5, 373–384.
- Simpson, I.J., Blake, N.J., Blake, D.R., Atlas, E., Flocke, F., Crawford, J.H., Fuelberg, H.E., Kiley, C.M., Meinardi, S., Rowland, F.S., 2003. Photochemical production and evolution of selected C₂–C₅ alkyl nitrates in tropospheric air influenced by Asian outflow. *J. Geophys. Res. Atmospheres* 108, 8808. <https://doi.org/10.1029/2002JD002830>
- Simpson, I.J., Meinardi, S., Blake, D.R., Blake, N.J., Rowland, F.S., Atlas, E., Flocke, F., 2002. A biomass burning source of C₁–C₄ alkyl nitrates. *Geophys. Res. Lett.* 29, 2168. <https://doi.org/10.1029/2002GL016290>
- Singh, H.B., Salas, L., Herlth, D., Kolyer, R., Czech, E., Avery, M., Crawford, J.H., Pierce, R.B., Sachse, G.W., Blake, D.R., Cohen, R.C., Bertram, T.H., Perring, A., Wooldridge, P.J., Dibb, J., Huey, G., Hudman, R.C., Turquety, S., Emmons, L.K., Flocke, F., Tang, Y., Carmichael, G.R.,

- Horowitz, L.W., 2007. Reactive nitrogen distribution and partitioning in the North American troposphere and lowermost stratosphere. *J. Geophys. Res.* 112. <https://doi.org/10.1029/2006JD007664>
- Sorooshian, A., Murphy, S.N., Hersey, S., Gates, H., Padro, L.T., Nenes, A., Brechtel, F.J., Jonsson, H., Flagan, R.C., Seinfeld, J.H., 2008. Comprehensive airborne characterization of aerosol from a major bovine source. *Atmos. Chem. Phys.* 8, 5489–5520.
- Stockwell, C.E., Veres, P.R., Williams, J., Yokelson, R.J., 2015. Characterization of biomass burning emissions from cooking fires, peat, crop residue, and other fuels with high-resolution proton-transfer-reaction time-of-flight mass spectrometry. *Atmos. Chem. Phys.* 15, 845–865. <https://doi.org/10.5194/acp-15-845-2015>
- Stroud, C.A., Roberts, J.M., Williams, J., Goldan, P.D., Kuster, W.C., Ryerson, T.B., Sueper, D., Parrish, D.D., Trainer, M., Fehsenfeld, F.C., Flocke, F., Schauffler, S.M., Stroud, V.R.F., Atlas, E., 2001. Alkyl nitrate measurements during STERAO 1996 and NARE 1997: Intercomparison and survey of results. *J. Geophys. Res. Atmospheres* 106, 23043–23053. <https://doi.org/10.1029/2000JD000003>
- Thornberry, T., Carroll, M.A., Keeler, G.J., Sillman, S., Bertman, S.B., Pippin, M.R., Ostling, K., Grossenbacher, J.W., Shepson, P.B., Cooper, O.R., Moody, J.L., Stockwell, W.R., 2001. Observations of reactive oxidized nitrogen and speciation of NO_y during the PROPHET summer 1998 intensive. *J. Geophys. Res. Atmospheres* 106, 24359–24386. <https://doi.org/10.1029/2000JD900760>
- Timkovsky, J., Dusek, U., Henzing, J.S., Kuipers, T.L., Röckmann, T., Holzinger, R., 2015. Offline thermal-desorption proton-transfer-reaction mass spectrometry to study composition of organic aerosol. *J. Aerosol Sci.* 79, 1–14. <https://doi.org/10.1016/j.jaerosci.2014.08.010>
- Turnipseed, A.A., Huey, L.G., Nemitz, E., Stickel, R., Higgs, J., Tanner, D.J., Slusher, D.L., Sparks, J.P., Flocke, F., Guenther, A., 2006. Eddy covariance fluxes of peroxyacetyl nitrates (PANs) and NO_y to a coniferous forest. *J. Geophys. Res. Atmospheres* 111, D09304. <https://doi.org/10.1029/2005JD006631>
- VandenBoer, T.C., Markovic, M.Z., Petroff, A., Czar, M.F., Borduas, N., Murphy, J.G., 2012. Ion chromatographic separation and quantitation of alkyl methylamines and ethylamines in atmospheric gas and particulate matter using preconcentration and suppressed conductivity detection. *J. Chromatogr. A* 1252, 74–83. <https://doi.org/10.1016/j.chroma.2012.06.062>
- Walker, J.T., Dombek, T.L., Green, L.A., Gartman, N., Lehmann, C.M.B., 2012. Stability of organic nitrogen in NADP wet deposition samples. *Atmos. Environ.* 60, 573–582. <https://doi.org/10.1016/j.atmosenv.2012.06.059>
- Wang, Y., Hu, M., Lin, P., Guo, Q., Wu, Z., Li, M., Zeng, Limin, Song, Y., Zeng, Liwu, Wu, Y., Guo, S., Huang, X., He, L., 2017. Molecular Characterization of Nitrogen-Containing Organic

- Compounds in Humic-like Substances Emitted from Straw Residue Burning. *Environ. Sci. Technol.* 51, 5951–5961. <https://doi.org/10.1021/acs.est.7b00248>
- Wentzell, J.J.B., Liggio, J., Li, S.-M., Vlasenko, A., Staebler, R., Lu, G., Poitras, M.-J., Chan, T., Brook, J.R., 2013. Measurements of Gas phase Acids in Diesel Exhaust: A Relevant Source of HNCO? *Environ. Sci. Technol.* 47, 7663–7671. <https://doi.org/10.1021/es401127j>
- Whitall, D.R., Paerl, H.W., 2001. Spatiotemporal Variability of Wet Atmospheric Nitrogen Deposition to the Neuse River Estuary, North Carolina. *J. Environ. Qual.* 30, 1508–1515. <https://doi.org/10.2134/jeq2001.3051508x>
- Williams, E.J., Baumann, K., Roberts, J.M., Bertman, S.B., Norton, R.B., Fehsenfeld, F.C., Springston, S.R., Nunnermacker, L.J., Newman, L., Olszyna, K., Meagher, J., Hartsell, B., Edgerton, E., Pearson, J.R., Rodgers, M.O., 1998. Intercomparison of ground-based NO_y measurement techniques. *J. Geophys. Res. Atmospheres* 103, 22261–22280. <https://doi.org/10.1029/98JD00074>
- Williams, E.J., Roberts, J.M., Baumann, K., Bertman, S.B., Buhr, S., Norton, R.B., Fehsenfeld, F.C., 1997. Variations in NO_y composition at Idaho Hill, Colorado. *J. Geophys. Res. Atmospheres* 102, 6297–6314. <https://doi.org/10.1029/96JD03252>
- Yokelson, R.J., Griffith, D.W.T., Ward, D.E., 1996. Open-path Fourier transform infrared studies of large-scale laboratory biomass fires. *J. Geophys. Res.* 101, 21067. <https://doi.org/10.1029/96JD01800>
- You, Y., Kanawade, V.P., de Gouw, J.A., Guenther, A.B., Madronich, S., Sierra-Hernández, M.R., Lawler, M., Smith, J.N., Takahama, S., Ruggeri, G., Koss, A., Olson, K., Baumann, K., Weber, R.J., Nenes, A., Guo, H., Edgerton, E.S., Porcelli, L., Brune, W.H., Goldstein, A.H., Lee, S.-H., 2014. Atmospheric amines and ammonia measured with a chemical ionization mass spectrometer (CIMS). *Atmos. Chem. Phys.* 14, 12181–12194. <https://doi.org/10.5194/acp-14-12181-2014>
- Zamora, L.M., Prospero, J.M., Hansell, D.A., 2011. Organic nitrogen in aerosols and precipitation at Barbados and Miami: Implications regarding sources, transport and deposition to the western subtropical North Atlantic. *J. Geophys. Res.* 116. <https://doi.org/10.1029/2011JD015660>
- Zhang, J., Wang, Y., Huang, X., Liu, Z., Ji, D., Sun, Y., 2015. Characterization of organic aerosols in Beijing using an aerodyne high-resolution aerosol mass spectrometer. *Adv. Atmospheric Sci. Dordr.* 32, 877–888. <http://dx.doi.org/10.1007/s00376-014-4153-9>
- Zhang, Q., Anastasio, C., 2003. Conversion of Fogwater and Aerosol Organic Nitrogen to Ammonium, Nitrate, and NO_x during Exposure to Simulated Sunlight and Ozone. *Environ. Sci. Technol.* 37, 3522–3530. <https://doi.org/10.1021/es034114x>

Zhang, Q., Anastasio, C., Jimenez, J.L., 2002. Water-soluble organic nitrogen in atmospheric fine particles (PM_{2.5}) from northern California. *J. Geophys. Res.* 107. <https://doi.org/10.1029/2001JD000870>

Zheng, W., Flocke, F.M., Tyndall, G.S., Swanson, A., Orlando, J.J., Roberts, J.M., Huey, L.G., Tanner, D.J., 2011. Characterization of a thermal decomposition chemical ionization mass spectrometer for the measurement of peroxy acyl nitrates (PANs) in the atmosphere. *Atmospheric Chem. Phys.* 11, 6529–6547. <https://doi.org/10.5194/acp-11-6529-2011>

3.2. Modeled Total Nr Deposition Budgets

Modeling the Nr deposition budgets is another field where research is needed to address many existing knowledge gaps. A key limitation to CTMs is the handling of the bidirectional air-surface exchange exhibited by many compounds and most notably for the Nr budget, NH₃. Background on the state of the science is provided for more effective means of incorporating measurements of NH₃ into modeling frameworks in Section **3.2.1. Application of a bidirectional ammonia air-surface exchange model at NADP AMoN sites**. Models that predict deposition fluxes within vegetative canopies need to be updated to current levels of modern scientific understanding, measurement techniques, and computational methods as described in Section **3.2.2. Development of in-canopy source/sink models that resolve deposition to ecosystem components (crown, understory, ground) and in-canopy chemistry**.

The scope of the CTMs is expansive. In addition to the major needs in model development described above, there are specific knowledge gaps related to particle formation, scavenging processes, and atmospheric chemistry mechanisms. Such improvements are routinely incorporated into newer versions of CTMs and Section **3.2.3. Modeling fluxes of Nr using chemical transport models** describes the current state of the models and the most pressing knowledge gaps relevant to the Nr deposition budget. The modeled estimates of Nr deposition have uncertainty which is not well understood and needs to be quantified as discussed in Section **3.2.4. Assessing uncertainty in total Nr deposition estimates for North American critical load applications**.

3.2.1. Application of a bidirectional ammonia air-surface exchange model at NADP AMon sites

John T. Walker¹, Melissa Puchalski², Selma Isil³, Christopher Rogers³, Kevin Mishoe³, Taylor Macy², Ralph Baumgardner¹, Zhiyong Wu¹, Donna Schwede¹, Jesse Bash¹

¹U.S. EPA, Office of Research and Development, Durham, NC

²U.S. EPA, Office of Air Programs, Washington, DC

³Wood Environment & Infrastructure Solutions, Inc., Newberry, FL

Research topic summary

Deposition assessments that require information on the magnitude and spatiotemporal patterns of NH₃ dry deposition currently rely on limited direct flux measurements and output from gridded chemical transport models. Measurements of two-week integrated NH₃ air concentrations provided by NADP's AMon represent a potentially valuable dataset for estimating ecosystem specific NH₃ fluxes via bidirectional flux modeling. However, several aspects of such a modeling framework specific to the use of time integrated measurements, choice of meteorological input, and complexity of biogeochemical parameterizations, need to be addressed prior to implementation across the network. Assessment of any bias associated with use of time-integrated concentration data and the development of a protocol to minimize such bias could be accomplished in the relatively short term, along with further evaluation of the accuracy of the model against recent NH₃ flux measurements. Implementation of this modeling framework across the AMon network as an NADP data product is likely feasible by 2021 and considered near-term. Expansion of AMon into ecological monitoring networks to leverage data for flux modeling is a longer term effort.

There are also a number of knowledge and data gaps limiting further development of the bidirectional NH₃ modeling framework itself, representing a range of near- and long-term research efforts. Evaluation and standardization of methods for determining soil compensation points in natural and agricultural systems and evaluation of the importance of leaf litter as a source of NH₃ could be accomplished in the relatively near term through a combination of field and laboratory measurements. Development of relationships between stomatal compensation points derived from bulk tissue versus apoplast chemistry for North American vegetation types, as well as development of databases of soil and vegetation emission potentials sufficient for regional modeling represent long-term efforts. Improvement of cuticular resistance parameterizations incorporating more advanced surface wetness schemes into bidirectional

flux models is also an important long-term goal that will require direct flux measurements across a range of conditions.

Introduction

The AMoN network is the first and only national network measuring concentrations of gaseous NH₃. Concentrations are measured at two-week averaging periods using passive sampling technology across a wide range of terrestrial ecosystems of differing climatology, atmospheric chemistry, and deposition patterns. AMoN measurements are used in assessments of spatial and temporal patterns of NH₃ emissions (Zhu et al., 2013) and concentrations (Schiferl et al., 2016), regional trends in air concentrations (Butler et al., 2016), and validation of satellite retrievals (Shephard et al., 2011) and chemical transport models (CTMs) (Battye et al., 2016). However, the use of AMoN data for dry deposition assessments is more limited (Li et al., 2016). NH₃ fluxes derived from site specific NH₃ concentration measurements (AMoN) and surface parameterizations (compensation points) could provide “best” model estimates of NH₃ deposition for a number of applications, including:

- developing ecosystem specific Nr deposition budgets
- assessing long term spatial and temporal trends in Nr deposition
- assessing sub-grid variability of NH₃ fluxes within gridded CTMs
- improving estimates of NH₃ deposition in NADP total deposition maps

However, several aspects of such a modeling framework, specific to the use of time integrated measurements, choice of meteorological input, and complexity of biogeochemical parameterizations, need to be addressed prior to implementation across the network. This section outlines a project to develop and evaluate a methodology for using two-week average AMoN concentrations in a bi-directional NH₃ flux model framework. This effort represents the first step toward providing NADP with a model for calculating and reporting net and component NH₃ fluxes at AMoN sites. Knowledge and data gaps limiting further development of bidirectional NH₃ flux models, in general, are also discussed.

State of the science

AMoN network

The AMoN network began in 2007 as a pilot network with 20 sites measuring NH₃ using passive samplers. The network was approved as an official NADP network in 2010 and has grown to more than 90 sites with sites throughout the U.S., Canada, and Puerto Rico (see Figure 1). Sites are located away from emissions sources (i.e. large agricultural sources, industrial facilities) to provide a regionally representative signal. Network sites are supported by federal agencies, state agencies, universities, and tribes. The NADP designed the network to use passive samplers to allow for broad participation in a low-cost, spatially dense network. Radiello[®] passive

samplers are deployed bi-weekly on Tuesday mornings, following the traditional NADP and CASTNET sampling schedule.

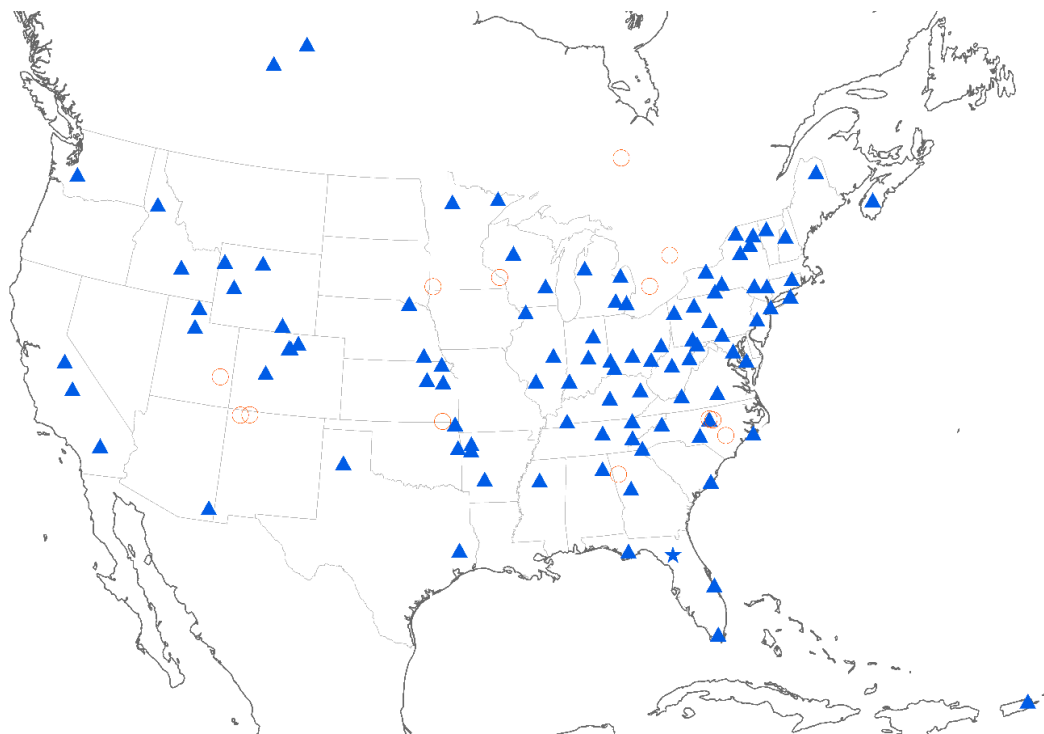

Figure 1. AMoN site map as of July 11, 2017. Blue triangles represent active sites, blue star represents short-term special study site and circles represent inactive AMoN sites

The NADP Central Analytical Laboratory prepares, ships, and analyzes the samplers following the procedures documented in the NADP Quality Assurance documents (i.e. NADP, 2016). Triplicate samplers are deployed at 5% of the network sites to assess overall network precision. Historically, variability between the passive samplers has been less than 5%. The passive samplers have been compared to a URG denuder reference method, most recently at 5 collocated CASTNET and AMoN sites (Puchalski et. al., 2015), showing very good agreement between the active and passive samplers.

In 2016, the average annual ambient concentrations of NH_3 as measured by AMoN ranged from $0.23 \mu\text{g m}^{-3}$ in New Hampshire to $15.82 \mu\text{g m}^{-3}$ in Logan, Utah. Seasonal patterns and concentrations vary depending on the source region (i.e. animal operations nearby versus impacts from fertilizer application). In Butler et. al. (2016), trends from 18 sites that have been operating for more than 8 years showed statistically significant increasing trends in ambient NH_3 in all regions even though this trend is not reflected in EPA's National Emissions Inventory (Butler et. al., 2016). Trends and regional comparisons from AMoN will continue to be important for understanding NH_3 contributions to $\text{PM}_{2.5}$ and estimates of total Nr deposition to sensitive ecosystems, as well as evaluation of CTMs and remote sensing techniques (Zhu et al., 2013, 2015; van Damme et al., 2015; Battye et al., 2016).

Bidirectional NH₃ flux modeling

A comprehensive discussion of the state of the science of bidirectional flux modeling is provided by Flechard et al. (2013) and only the most recent advances will therefore be described here. A commonly used bi-directional NH₃ modeling framework is the two-layer resistance model developed by Nemitz et al., 2001 (Figure 2).

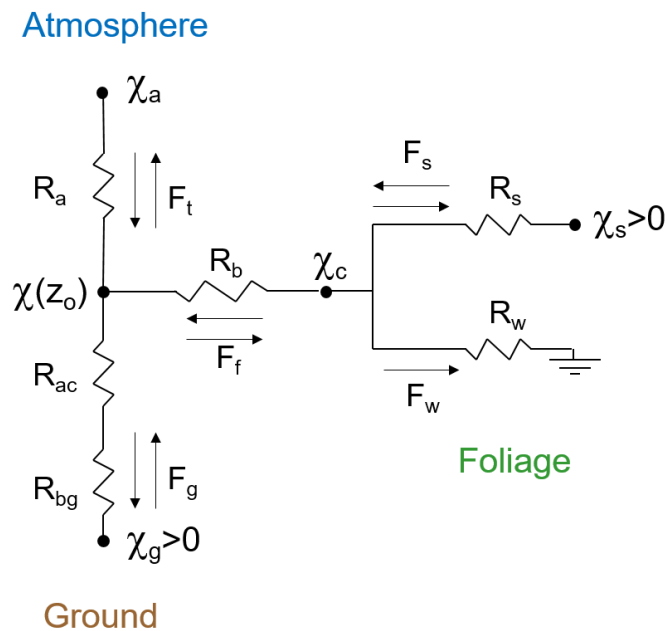

Figure 2. Two-layer foliage/ground resistance model of Nemitz et al, 2001.

In this modeling framework, the competing processes of emission and deposition within the foliage (vegetation)-ground system are taken into account by relating the net canopy-scale NH₃ flux (F_t) to the net emission potential of the canopy (i.e., foliage and ground), or surface concentration ($\chi(z_o)$), which is in turn related to the canopy compensation point (χ_c). The compensation point is the atmospheric concentration at which the net surface exchange is zero, i.e., the concentration at which the atmosphere is at equilibrium with the underlying surface. The surface is a sink for atmospheric NH₃ when the atmospheric concentration exceeds the compensation point and emits NH₃ to the atmosphere under the opposite condition. The system of equations describing the net canopy flux (F_t), as well as component fluxes [i.e., stomatal (F_s), cuticular (F_w), and ground (F_g)], is given by Nemitz et al. (2001).

Total and component fluxes are dependent on the canopy compensation point (χ_c), defined by Nemitz et al. (2001) as

$$\begin{aligned} \chi_c = & [\chi_a (R_a R_b)^{-1} + \chi_s \{ (R_a R_s)^{-1} + (R_b R_s)^{-1} + (R_g R_s)^{-1} \} + \chi_g (R_b R_g)^{-1}] \\ & \times \{ (R_a R_b)^{-1} + (R_a R_s)^{-1} + (R_a R_w)^{-1} + (R_b R_g)^{-1} + (R_b R_s)^{-1} \\ & + (R_b R_w)^{-1} + (R_g R_s)^{-1} + (R_g R_w)^{-1} \}^{-1} \end{aligned} \quad (1)$$

where χ_a is the atmospheric NH_3 concentration, R_a is the atmospheric aerodynamic resistance, R_b is the atmospheric boundary layer resistance, R_s is the leaf stomatal resistance, R_w is the leaf cuticular resistance, and χ_s is the leaf stomatal compensation point. NH_3 exchange with the ground is described by the soil compensation point (χ_g) and the ground resistance ($R_g = R_{ac} + R_{bg}$), which is determined by the in-canopy aerodynamic (R_{ac}) and ground boundary-layer resistances (R_{bg}).

Upon determination of χ_c , the surface concentration [$\chi(z_0)$] may be calculated according to

$$\chi(z_0) = \frac{\chi_a R_a^{-1} + \chi_g R_g^{-1} + \chi_c R_b^{-1}}{R_a^{-1} + R_b^{-1} + R_g^{-1}} \quad (2)$$

The net flux may then be calculated as:

$$F_t = - \frac{\chi_a - \chi(z_0)}{R_a} \quad (3)$$

Variants of this basic framework have been implemented in regional (Zhang et al., 2010; Pleim et al., 2013) and global (Zhu et al., 2013) CTMs. The reader is referred to Massad et al., 2010 and references therein for a review of commonly used parameterizations for atmospheric and stomatal resistance parameterizations. Below we briefly summarize the state of the science with respect to parameterization of biological processes affecting bidirectional NH_3 exchange, specifically the leaf (i.e., stomatal, χ_s) and ground (χ_g) compensation points. The reader is referred to Section **3.1.1.2 Measurements of surface chemistry/wetness relevant to fluxes** for a more detailed discussion of cuticular flux processes.

Ground (g) and stomatal (s) compensation points may be described according to Nemitz et al. (2000) as a function of temperature and the aqueous concentrations of NH_4^+ and H^+ in the leaf apoplast or soil pore solution:

$$X_{s,g} = \frac{161500}{T} \exp\left(-\frac{10380}{T}\right) \frac{[\text{NH}_4^+]}{[\text{H}^+]} \quad (4)$$

The emission potential ($\Gamma_{g,s}$), or “gamma”, is represented by the ratio of NH_4^+ to H^+ in solution and the direction of flux to or from the surface depends on the gradient between $X_{s,g}$ and X_c .

Direct measurements of soil and vegetation chemistry as well as on-site micrometeorology are labor- and cost-prohibitive for most field-scale and national-scale applications. Therefore, existing data sets from the literature are typically used to parameterize compensation points for developing biogeochemical processes required to drive the NH_3 flux model. The existing data sets provide estimates for vegetation or soil conditions but error associated with extrapolation to other sites is not well characterized. Reviews of NH_3 compensation points and emission potentials are described below.

Stomatal compensation point

The stomatal compensation point may be estimated from canopy-scale flux measurements (Flechard et al., 1998) or determined directly from enclosure-based gas exchange measurements (Hill et al., 2001) or extraction and analysis of the leaf apoplast solution (Husted et al., 2000). Given the difficulties of extracting the apoplast directly, recent efforts have drawn on the relationships between the NH_4^+ content of the apoplast and leaf tissue to estimate X_s from bulk chemical analysis of vegetation tissue (Mattsson et al., 2009; Massad et al., 2010). Stomatal emission potentials, compensation points and relevant leaf chemistry have been compiled by Zhang et al. (2010) and Massad et al. (2010). These databases and reviews of existing studies provide constraints for parameterizing bi-directional flux models. Studies show a range of stomatal emission potential values depending on vegetation species and land use type (forest, semi-natural, managed) (Massad et al., 2010; Zhang et al., 2010). While natural and semi-natural vegetation (i.e. forests) generally have X_s values close to zero, representing a sink for NH_3 , agricultural landscapes tend to be a source of NH_3 . For managed systems, stomatal emission potential increases immediately after fertilization with a return to the pre-fertilization emission potential within several days to weeks. Fertilization typically occurs in the spring and summer which results in a seasonal pattern for the canopy compensation point over managed systems. Stomatal compensation points have also been shown to increase during leaf senescence (Mattsson and Schjoerring, 2003).

The data syntheses of Massad et al. (2010) and Zhang et al. (2010) indicate that more information exists for managed (i.e., crops) versus unmanaged (i.e. natural/semi-natural) ecosystems. For natural ecosystems, grassland and other short vegetation (e.g., heathland) have been studied much more extensively than forests. Finally, existing data were primarily collected in European ecosystems. With respect to improvement of bi-directional flux modeling for North America, more data are needed for natural systems, specifically grasslands and forests. Examples of estimates of X_s derived from bulk tissue NH_4^+ are shown in Figure 3 for several tree species at a deciduous forest site in southwestern North Carolina. Differences between understory (*Rhododendron* (*Rhododendron maximum* L.), Mountain laurel (*Kalmia latifolia* L.), and Red maple (*Acer rubrum* L.)) and canopy species (White oak (*Quercus alba* L.), Hickory (*Carya* spp.)) demonstrate the variability that may exist at the canopy and stand scale in a mixed hardwood forest.

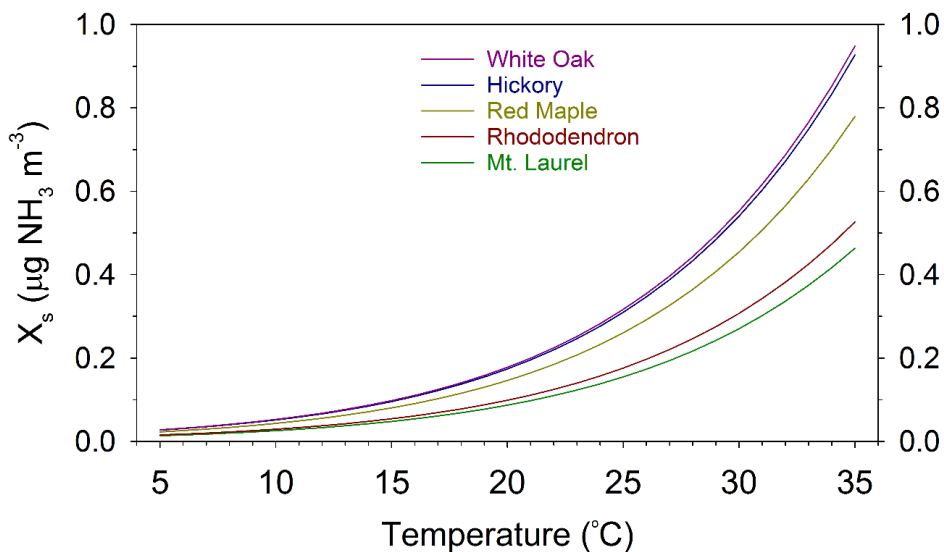

Figure 3. Estimated stomatal compensation point for canopy (White oak, Hickory) and understory (Red maple, Rhododendron, Mt. laurel) species in a montane deciduous forest in southwestern North Carolina. Compensation point parameterized from measurements of bulk tissue NH_4^+ content (Massad et al., 2010) collected during spring 2015.

Ground compensation point

Similar to the stomatal compensation point, the soil emission potential (I_g) and compensation point may be derived from measurements of the pH and NH_4^+ content of soil pore water (Nemitz et al., 2001). Measurements of (I_g) for a number of field and laboratory studies are summarized by Massad et al. (2010). As with the stomatal emission potential, most measurements have understandably been conducted in fertilized cropping systems where emissions from the soil are large. Fewer measurements have been conducted in natural systems. Because forest mineral and organic soils are typically characterized by small NH_4^+ pools and relatively low pH, they are expected to be a sink for NH_3 . In contrast to forests, grassland soils, where pH may exceed 7.0, may represent net sources of NH_3 to the atmosphere (Langford et al., 1992). Regarding estimation of the soil compensation point, comparisons of measured soil chemistry and canopy-scale flux measurements indicate that determinations of total soil extractable NH_4^+ may overestimate soil emission potentials (Nemitz et al., 2001; Cooter et al., 2010; Flechard et al., 2013). Alternatives for deriving more realistic estimates of the amount of soil NH_4^+ available for exchange with the atmosphere include extraction of the soil with solutions of lower ionic strength, such as 0.01 M CaCl_2 as opposed to 2M KCl (Cooter et al., 2012), or modeling of the dissolved NH_4^+ concentration based on total extractable NH_4^+ and cation exchange characteristics of the soil (Vogeler et al., 2010; Venterea et al., 2015).

Additional measurements of soil emission potential are needed in natural systems across a range of soil N_r pools and pH. For agricultural systems, measurements of soil emission potential which capture the dynamics of soil NH₄⁺ and pH post-fertilization are important. NH₄⁺ adsorption models (Vogeler et al., 2010; Venterea et al., 2015) show promise for application to NH₃ bidirectional exchange modeling but require validation across a range of NH₄⁺ concentration (including natural ecosystems), soil cation exchange capacity, and soil texture.

While the ground emission potential (Γ_g) is usually assumed to represent the soil, emission or uptake by decaying leaf litter on the soil surface is another potentially important process in natural ecosystems (Hansen et al., 2013, 2017). Studies have shown that litter has an emission potential that may be higher than the stomatal and soil emission potentials depending on the type of litter and extent of decomposition (David et al., 2009; Herrmann et al., 2009; Mattson et al., 2009; Sutton et al., 2009). Figure 4 summarizes two sets of in-canopy vertical concentration profiles in mixed deciduous forests in North Carolina. Both indicate a source of NH₃ at the forest floor (i.e., decreasing concentration with height above the ground) which may reflect emissions from the litter layer. Measurements of litter chemistry are needed in a range of different natural ecosystems to better understand the potential importance of this emission process with respect to net ecosystem NH₃ fluxes and to inform necessary refinements to bidirectional exchange models (Hansen et al., 2017).

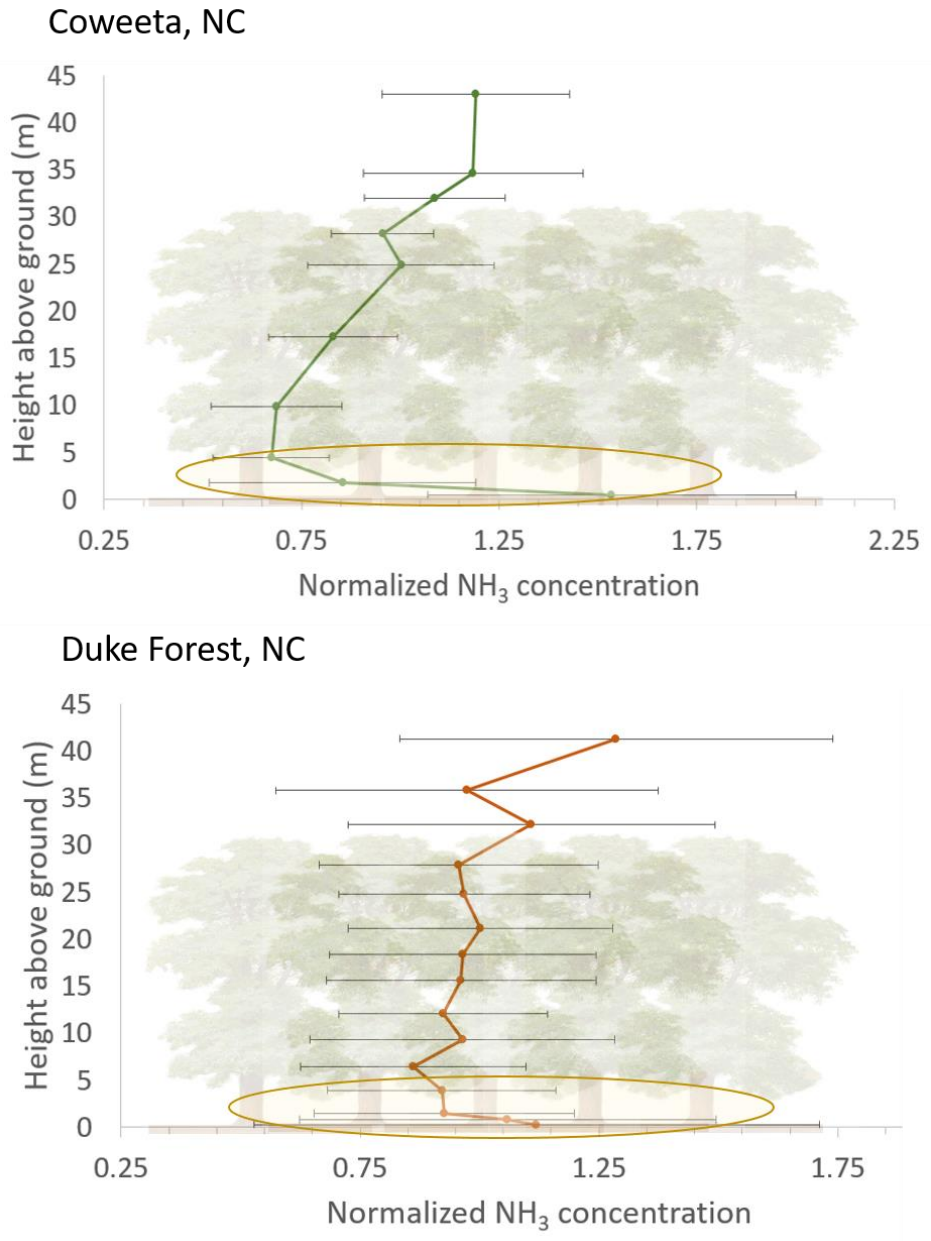

Figure 4. In-canopy vertical profiles of NH₃ concentration in two mixed hardwood forests in North Carolina. Height-wise NH₃ measurements for individual profiles have been normalized by the corresponding profile mean and then averaged for all profiles. Error bars represent ± 1 standard deviation. Averages represent daytime profiles only. Coweeta results comprise n = 19 daytime profiles collected during summer 2016. Duke Forest results comprise n = 23 daytime profiles measured during summer 2009. Individual profiles were measured over 3 – 4 hour periods using phosphorous acid coated annular denuders. Circled regions show decreasing concentration just above forest floor indicative of emission.

Future research

In the following section we describe ongoing and future efforts to implement bidirectional NH_3 flux modeling at NADP AMoN sites and to develop supporting biogeochemical datasets for vegetation and ground NH_3 emission potentials.

Bidirectional modeling framework

The modeling framework implemented at AMoN sites will follow the two-layer resistance framework shown in Figure 2. Parameterizations for atmospheric resistances are described in Pleim and Ran (2011). In-canopy and cuticular resistance parameterizations are described by Massad et al. (2010) and parameterization of the soil resistance is described by Cooter et al. (2010). For network-wide implementation, meteorological inputs will be provided by a weather forecast model. Net and component (i.e., stomatal, cuticular, and ground) fluxes will be calculated at the hourly time step after temporally scaling the two-week integrated AMoN concentration to hourly values as described below.

Biogeochemical datasets of emission potentials

To assist in the development and testing of the AMoN NH_3 flux modeling methodology, EPA is conducting a three-site pilot study to develop databases of measured soil and vegetation biogeochemistry, canopy physical characteristics, and in-situ measurements of micrometeorology (friction velocity, momentum and heat fluxes) and surface conditions (wetness, soil moisture, soil temperature). Sites include Chiricahua National Monument, Arizona; Bondville, Illinois; and Duke Forest, North Carolina. Chiricahua National Monument is located in southeast Arizona with dominant vegetation species including desert grasses, sagebrush, oak and juniper. The Bondville AMoN site, operated by the University of Illinois – Champaign, is located in central Illinois surrounded by agricultural fields. The Duke Forest site is a mix of forest and grassland located near Chapel Hill, North Carolina.

The three pilot sites were selected to represent a range of atmospheric chemistry and biogeochemical characteristics. Chiricahua and Duke Forest are both natural ecosystems experiencing similar atmospheric concentrations of NH_3 but have very different physical (canopy) and biogeochemical characteristics. For example, Chiricahua is dominated by grassland with sparse shrubs and short trees. Ecosystem N_r pools are expected to be small in these desert soils but pH is expected to be relatively high (Schlesinger et al., 1996). Thus, this site may exhibit a relatively large soil emission potential for a natural system with minimal litter on the soil surface. High temperatures create the potential for large soil and vegetation compensation points relative to atmospheric NH_3 levels. By contrast, Duke Forest has a potentially important litter emission component. Bondville, Illinois experiences higher atmospheric NH_3 concentrations than either Chiricahua or Duke Forest and is surrounded by agricultural fields. Soils at the Bondville site will exhibit very high emission potentials following fertilizer application to surrounding crops.

Measurements to be conducted at the pilot sites are summarized in Table 1. Soil and vegetation samples are collected seasonally at approximately 15 locations within a 1-km radius of the AMoN site, targeting primary soil types identified in the NRCS Web Soil Survey (USDA NRCS, 2017) and primary vegetation species identified in the Landscape Fire and Resource Management Planning Tools (Landfire, 2017) database.

Table 1. Measurements to be conducted at AMoN pilot sites.

Category	Parameter	Frequency
Meteorological measurements	3D wind components and temperature by sonic anemometer, solar radiation, temperature, wetness, wind speed and direction, precipitation	Continuous
Soil conditions	Moisture, temperature	Continuous
Soil chemistry	[NH ₄ ⁺], [NO ₃ ⁻], pH	Seasonal sampling of dominant soil types
Vegetation properties	LAI	Seasonal
Vegetation chemistry	Bulk leaf and litter analyzed for moisture, total [N], [NH ₄ ⁺], pH	Seasonal sampling of litter and dominant vegetation species
Atmospheric chemistry	NH ₄ ⁺ , NH ₃ , HNO ₃ , NO ₃ ⁻ , SO ₂ , SO ₄ ²⁻ ,	Weekly CASTNET filter pack (NH ₄ ⁺) and bi-weekly AMoN (NH ₃) concentrations
Wet deposition	NH ₄ ⁺ and other routine NADP analytes	Weekly NADP/NTN concentrations and deposition

The seasonal biogeochemical measurements will be used to parameterize vegetation, soil, and litter emission potentials following Nemitz et al. (2000) and Massad et al. (2010). A subset of soils will be used to develop NH₄⁺ adsorption curves (Vogeler et al., 2010).

Development and testing for AMoN application

Application of the bidirectional flux model across the AMoN poses several challenges with potential sources of uncertainty that need to be characterized. First, AMoN concentrations are integrated over a two-week period. Use of a two-week average concentration will lead to positive or negative biases in concentration depending on time of day and patterns of longer-term variability over the two-week averaging period. Bias in the modeled flux results from the influence of the concentration bias on ground and vegetation exchange rates and correlation of the air concentration with atmospheric resistances that govern the exchange velocity (described in more detail below). Second, most AMoN sites do not measure meteorology in-situ. Meteorological inputs are therefore provided by a model, which represents an additional

source of uncertainty. Furthermore, it is impractical to collect the necessary biogeochemical measurements required for model parameterization at all AMoN sites in the near term. Prescription of emission potentials based on literature values also introduces uncertainty. As described below, our approach will be to use data collected during the 3-site pilot study and other existing datasets to characterize and develop methodologies for characterizing and minimizing these sources of error and uncertainty in the model.

Impact of temporal averaging of air concentration on modeled fluxes

The use of time-integrated (temporally averaged) air concentrations may produce error in the modeled NH₃ flux due to bias in the air concentration at the hourly time scale and covariance between the atmospheric concentration and other variables that drive the flux (i.e., exchange velocity). Schrader et al. (2017) have investigated this issue in detail and have developed a correction scheme to minimize bias associated with use of time-integrated air concentrations for NH₃ flux modeling. Their approach is based on a simplified version of the bidirectional exchange model in which the atmospheric resistances (R_a and R_b) act in series with a total surface resistance ($R_f = (R_s^{-1} + R_w^{-1})^{-1}$) such that the bidirectional flux (F) is defined as

$$F = -v_{ex} \cdot (\chi_a - \chi_f). \quad (5)$$

Here v_{ex} is the exchange velocity ($v_{ex} = (R_a + R_b + R_f)^{-1}$) and χ_f is the “foliage” compensation point. With this modeling framework, the error induced from calculating fluxes using time-integrated concentrations can be calculated directly with estimates of the standard deviations of hourly v_{ex} and NH₃ concentration (χ_a) and the Pearson correlation coefficient for the relationship between v_{ex} and χ_a . Based on this approach, they recommend correcting fluxes calculated from hourly observations of meteorological drivers and time-integrated concentrations by taking parallel measurements with a high-frequency NH₃ monitor for a limited time to parameterize functions to estimate the standard deviation of NH₃ concentrations and the correlation of air NH₃ concentrations with v_{ex} .

Another approach for minimizing the bias associated with temporal averaging is to scale the two-week integrated concentration to produce a concentration time series of the same frequency (i.e., hourly) as the meteorological drivers. For example, this can be done for an AMoN site by applying the diurnal profile predicted by an atmospheric CTM. In this case, the AMoN two-week average concentration is maintained; the CTM diurnal profile is used only to impose hourly variation on the concentration. To develop an idea of the potential magnitude of the error associated with use of two-week integrated AMoN concentrations to model NH₃ fluxes, we conducted an analysis similar to Schrader et al. (2017) in which bi-weekly, seasonal and annual modeled fluxes were derived from hourly meteorology with hourly air concentrations versus hourly meteorology with two-week average concentrations. For this analysis we used a year of meteorological data from the Bondville, Illinois CASTNET site (short canopy) and parameterized a two-layer bidirectional NH₃ exchange model following Massad et

al. (2010). Atmospheric resistances and compensation points were computed at the hourly time step. We assumed an average annual air concentration of $1.5 \mu\text{g NH}_3 \text{ m}^{-3}$, which is the AMoN 2014 network-wide average, and a range of soil and vegetation emission potentials ($\Gamma = 25, 250, 500, 1000$). The annual air concentration was temporally scaled to produce a typical seasonal pattern peaking during warm months and by imposing a diurnal concentration profile that peaks in the early afternoon and reaches a minimum before sunrise. In this way, an hourly NH_3 concentration was produced that when averaged over two weeks is equal to the corresponding two-week integrated AMoN concentration.

By imposing this diurnal profile, which is typical of non-agricultural sites away from sources, the two-week integrated air concentration will be biased high at night and low during the day. We find that this bias in concentration produces an overestimate of cuticular deposition at night, which is the primary deposition pathway, and an underestimate of stomatal and ground deposition during the day at sites with low surface emission potential. At sites with higher surface emission potential, the concentration bias produces an overestimate of stomatal and ground emission during warm months. For this diurnal concentration profile, we also find that the correlation between air concentration and the maximum exchange velocity ($v_{\text{ex_max}} = 1/(R_a + R_b)$) is most significant during daytime hours, contributing additional bias to the modeled flux.

In our analysis, biases between fluxes computed using hourly versus two-week integrated concentrations at the bi-weekly time scale were both positive and negative and tended to offset when aggregating to seasonal and annual time scales. For example, simulations with an intermediate emission potential ($\Gamma = 250$) showed biases at the bi-weekly time scale of -65% to +10%, seasonal flux biases ranging from -15% to +4%, and annual bias of -6% for a corresponding flux of $1.2 \text{ kg NH}_3 \text{ ha}^{-1} \text{ y}^{-1}$. Percent bias increases as the magnitude of the flux decreases, corresponding to $\sim 15\%$ at $0.5 \text{ kg NH}_3 \text{ ha}^{-1} \text{ y}^{-1}$. Different patterns of air concentration, micrometeorology, and surface characteristics at other sites will result in differing magnitude and temporal patterns of bias.

Rather than adopting the diurnal profile predicted by a CTM for the site in question, another approach is to assign a representative diurnal profile based on time-resolved measurements from sites collected across a range of air concentrations and local source influences. AMoN site characteristics, including average air concentration, proximity to sources, etc., would then be used to assign an appropriate diurnal profile. Both of these options will be investigated and compared to the approach of Schrader et al., (2017) at sites where required hourly concentration and micrometeorological data exist.

Modeled versus measured meteorology

The NH_3 bidirectional exchange model requires hourly values of meteorological variables, such as temperature, wind speed, humidity, solar radiation, precipitation, and pressure, friction velocity, Monin-Obukhov length scale, and others. Collection of on-site meteorology can be expensive and an alternative approach is to use meteorological data from numerical

atmospheric models. For example, EPA archives runs from the Weather Research Forecast (WRF) model at a resolution of 12 km covering North America, providing a source of meteorological inputs for land-surface modeling at AMoN sites. A study will be conducted to compare the calculated NH₃ exchange fluxes using modeled versus on-site meteorological data over several different ecosystems where measured meteorology is available, including the three pilot sites. Statistical results of the comparison of fluxes derived from modeled versus observed meteorology (e.g., bias, error, and correlation) will be examined to characterize potential uncertainty associated with choice of meteorological inputs.

Sensitivity to biogeochemical inputs

As noted above, previous studies (e.g., Massad et al., 2010; Zhang et al., 2010) have compiled empirical values of Γ_s and Γ_g for different land-use types by summarizing available reports in the literature. It is impractical to measure the vegetation and ground emission potentials at all AMoN sites, at least in the near term. Thus, it is necessary to assess the uncertainty associated with use of in-situ measured biogeochemical model parameters versus values from the literature or derived from parameterizations based on other more easily obtainable data such as ecosystem total Nr deposition (Massad et al., 2010). An analysis will be conducted to examine the differences in calculated NH₃ flux over long periods (e.g., on a seasonal or annual basis) based on parameterizations of compensation point derived from in-situ measured biogeochemistry at the pilot sites versus alternative parameterizations. A second analysis will be conducted to quantify the sensitivity of the component and net model fluxes to the choice of Γ_s and Γ_g by varying them within a range based on values reported in the literature. Results will inform the level of uncertainty in modeled fluxes associated with parameterization of the stomatal ground emission potentials and the value of expanding in-situ biogeochemical measurements to other AMoN sites.

Measured versus modeled fluxes

The final step of the model evaluation will involve comparison to measured fluxes in natural and agricultural systems. Datasets include an unfertilized grass field (Rumsey and Walker, 2016), a mixed hardwood forest (Duke Forest), and fertilized corn (Walker et al., 2013) and soybean (Walker et al., 2006). Datasets include hourly fluxes and air concentrations, micrometeorology, surface wetness and soil conditions, and biogeochemistry needed to characterize emission potentials. These comparisons will inform the overall performance of the model and level of uncertainty expected upon implementation at AMoN sites.

Future research

As described above, several aspects of the AMoN bidirectional modeling framework need to be developed and characterized prior to implementation across the network. Assessment of the bias associated with use of time-integrated concentration and development of a protocol to minimize such bias could be accomplished in the relatively short term, along with further

evaluation of the accuracy of the model against recent NH₃ flux measurements. Implementation of the model across the AMoN network as an NADP data product is likely feasible by 2021.

There are also a number of knowledge and data gaps limiting further development of the bidirectional NH₃ modeling framework itself, representing a range of short and longer-term efforts. Evaluation and standardization of methods for determining soil compensation points in natural and agricultural systems and evaluation of the importance of leaf litter as a source of NH₃ could be accomplished in the relatively near term through a combination of field and laboratory measurements. Development of relationships between stomatal compensation points derived from bulk tissue versus apoplast chemistry for North American vegetation types, as well as development of databases of soil and vegetation emission potentials for regional modeling represent longer-term efforts. Advancement of cuticular resistance parameterizations incorporating more advanced surface wetness schemes into bidirectional flux models is also an important longer-term goal that will require direct flux measurements across a range of conditions.

Implementation of the bidirectional NH₃ flux model at AMoN sites links atmospheric chemistry, air-surface exchange, and biogeochemistry. The multi-disciplinary aspect of this effort creates opportunity for collaboration with other national ecological networks such as Ameriflux (<https://ameriflux.lbl.gov/>). Ameriflux sites measure carbon, water, and energy fluxes at approximately 110 sites in North and South America. With many sites collecting supporting measurements of biogeochemistry and canopy physical characteristics, these datasets can be used to drive the AMoN flux model, making expansion of AMoN to these locations beneficial to the goals of NADP and TDep. Conversely, the interests of Ameriflux with respect to atmosphere-biosphere exchange, biogeochemical N_r cycling, and the linkages between the carbon and N_r cycles make AMoN NH₃ flux estimates potentially useful to Ameriflux data users. Opportunities to collaborate with Ameriflux and other networks such as USDA Long term Ecological Research (LTER) sites could be explored as a path toward expansion of NADP, AMoN, and TDep efforts to better understand N_r fluxes to terrestrial and aquatic ecosystems. Expansion of AMoN into ecological monitoring networks to leverage data for flux modeling is a long-term effort.

References

Battye, W.H.; Bray, C.D.; Aneja, V.P.; Tong, D.; Lee, P.; Tang, Y. (2016) Evaluating ammonia (NH₃) predictions in the NOAA National Air Quality Forecast Capability (NAQFC) using in situ aircraft, ground-level, and satellite measurements from the DISCOVER-AQ Colorado campaign. *Atmos. Environ.* 140, 342–351.

- Butler, T.; Vermeylen, F.; Lehmann, C.M.; Likens, G.E.; Puchalski, M. (2016) Increasing ammonia concentration trends in large regions of the USA derived from the NADP/AMoN network. *Atmos. Environ.* 146, 132-140.
- Cooter, E.J.; Bash, J.O.; Walker, J.T.; Jones, M.R.; Robarge, W. (2010) Estimation of NH₃ bi-directional flux from managed agricultural soils. *Atmos. Environ.* 44, 2107-2115.
- David, M.; Loubet, B.; Cellier, P.; Mattsson, M.; Schjoerring, J.K.; Nemitz, E.; Roche, R.; Riedo, M.; Sutton, M.A. (2009) Ammonia sources and sinks in an intensively managed grassland using dynamic chambers. *Biogeosci. Disc.* 6, 1625-1655.
- Flechard, C.R.; Massad, R.-S.; Loubet, B.; Personne, E.; Simpson, D.; Bash, J.O.; Cooter, E.J.; Nemitz, E.; Sutton, M.A. (2013) Advances in understanding, models and parameterizations of biosphere-atmosphere ammonia exchange. *Biogeosciences*, 10, 5183–5225.
- Hansen, K.; Sørensen, L.L.; Hertel, O.; Geels, C.; Skjøth, C.A.; Jensen, B.; Boegh, E. (2013) Ammonia emissions from deciduous forest after leaf fall. *Biogeosciences* 10, 4577–4589.
- Hansen, K.; Personne, E.; Skjøth, C.A.; Loubet, B.; Ibrom, A.; Jensen, R.; Sorenson, L.L.; Beogh, E. (2017) Investigation sources of measured forest-atmospheric ammonia fluxes using tow-layer bi-directional modelling. *Agric. Forest Meteorol.* 237-238, 80-94.
- Herrmann, B.; Mattsson, M.; Jones, S.K.; Cellier, P.; Milford, C.; Sutton, M.A.; Schjoerring, J.K.; Neftel, A. (2009) Vertical structure and diurnal variability of ammonia exchange potential within an intensively managed grass canopy. *Biogeosciences* 6, 15-23.
- Husted, S.; Schjoerring, J.K.; Nielsen, K.H.; Nemitz, E.; Sutton, M.A. (2000) Stomatal compensation points for ammonia in oilseed rape plants under field conditions. *Agric. Forest Meteorol.* 105, 371-383.
- Landfire (2017) Online land use data. <https://www.landfire.gov/about.php>. Accessed April, 2018.
- Langford, A.O.; Fehsenfeld, F.C.; Zachariassen, J.; Schimel, D.S. (1992) Gaseous ammonia fluxes and background concentrations in terrestrial ecosystems of the United States. *Global Biogeochem. Cy.* 6, 459-483.
- Li, Y.; Schichtel, B.; Walker, J.T.; Schwede, D.B.; Chen, X.I.; Lehmann, C.; Puchalski, M.; Gay, D.; Collett, J.L. Jr. (2016) The Increasing Importance of Deposition of Reduced Nitrogen in the United States. *P. Natl. A. Sci. USA*, 113, 5874–5879.
- Massad, R.S.; Nemitz, E.; Sutton, M.A. (2010) Review and parameterization of bi-directional ammonia exchange between vegetation and the atmosphere. *Atmos. Chem. Phys.* 10, 10359-10386.
- Mattsson, M.; Schjoerring, J.K. (2003) Senescence-induced changes in apoplastic and bulk tissue ammonia concentrations of ryegrass leaves. *New Phytol.*, 160, 489–499.

- Mattsson, M.; Herrmann, B.; David, M.; Loubet, B.; Riedo, M.; Theobald, M.R.; Sutton, M.A.; Bruhn, D.; Neftel, A.; Schjoerring, J.K. (2009) Temporal variability in bioassays of the stomatal ammonia compensation point in relation to plant and soil nitrogen parameters in intensively managed grassland. *Biogeosciences* 6, 171-179.
- NADP (2016) National Atmospheric Deposition Program. NADP Network Quality Assurance Plan version 1.8, Revised 2016-04. Wisconsin State Laboratory of Hygiene. Madison, WI. https://nadp.slh.wisc.edu/lib/qaplans/NADP_Network_Quality_Assurance_Plan.pdf
- Nemitz, E.; Sutton, M.A.; Schjoerring, J.K.; Husted, S.; Wyers, G.P. (2000) Resistance modeling of ammonia exchange over oilseed rape. *Agr. For. Meteorol.* 2015, 405-425.
- Nemitz, E.; Milford, C.; Sutton, M.A. (2001) A two-layer canopy compensation point model for describing bi-directional biosphere-atmosphere exchange of ammonia. *Q. J. R. Meteorol. Soc.* 127, 815-833.
- Pleim, J.E.; Bash, J.O.; Walker, J.T.; Cooter, E. (2013) Development and evaluation of an ammonia bidirectional flux parameterization for air quality models. *J. of Geophys. Res. Atmospheres* 118, 3794-3806.
- Pleim, J.; Ran, L. (2011) Surface Flux Modeling for Air Quality Applications. *Atmosphere* 2, 271-302.
- Puchalski, M.A.; Rogers, C.M.; Baumgardner, R.; Mishoe, K.P.; Price, G.; Smith, M.J.; Watkins, N.; Lehmann, C.M. (2015) A statistical comparison of active and passive ammonia measurements collected at Clean Air Status and Trends Network (CASTNET) sites. *Environ. Sci.: Process & Impacts* 17, 358-369.
- Rumsey, I.; Walker, J.T. (2016) Application of an online ion chromatography-based instrument for gradient flux measurements of speciated nitrogen and sulfur. *Atmos. Meas. Tech.* 9, 2581-2592.
- Schiferl, L.D.; Heald, C.L.; Van Damme, M.; Clarisse, L.; Clerbaux, C.; Coheur, P.-F.; Nowak, J.B.; et al. (2016) Interannual Variability of Ammonia Concentrations over the United States: Sources and Implications. *Atmos. Chem. Phys.* 16, 12305–12328.
- Schlesinger, W.H.; Raikes, J.A.; Hartley, A.E.; Cross, A.F. (1996) On the spatial pattern of soil nutrients in desert ecosystems. *Ecology* 77, 364–374.
- Schrader, F.; Schaap, M.; Zoll, U.; Kranenburg, R.; Brummer, C. (2017) The hidden cost of using low-resolution concentration data in the estimation of NH₃ dry deposition fluxes. *Scientific Reports* 8, 969.

Shephard, M.W.; Cady-Pereira, K.E.; Luo, M.; Henze, D.K.; Pinder, R.W.; Walker, J.T.; Rinsland, C. P.; Bash, J.O.; Zhu, L.; Payne, V.H.; Clarisse, L. (2011) TES ammonia retrieval strategy and global observations of the spatial and seasonal variability of ammonia, *Atmos. Chem. Phys.* 11, 10743-10763.

Sutton, M.A.; Nemitz, E.; Milford, C.; Campbell, C.; Erisman, J.W.; Hensen, A.; Cellier, P.; Dvid, M.; Loubet, B.; Personne, E.; Schjoerring, J.K.; Mattsson, M.; Dorsey, J.R.; Gallagher, M.W.; Horvath, L.; Weidinger, T.; Meszaros, R.; Dammggen, U.; Neftel, A.; Herrmann, B.; Lehman, B.E.; Flechard, C.; Burkhardt, J. (2009) Dynamics of ammonia exchange with cut grassland: Synthesis of results and conclusions of the GRAMINAE integrated experiment. *Biogeosciences* 6, 2907-2934.

USDA (2017) U.S. Department of Agriculture. Online soil data. Accessed February, 2019. <https://websoilsurvey.sc.egov.usda.gov/App/HomePage.htm>

van Damme, M.; Clarisse, L.; Dammers, E.; Liu, X.; Nowak, J.B.; Clerbaux, C.; Flechard, C.R.; Galy-Lacaux, C.; Xu, W.; Neuman, J.A.; Tang, Y.S.; Sutton, M.A.; Erisman, J.W.; Coheur, P.F. (2015) Towards validation of ammonia (NH₃) measurements from the IASI satellite, *Atmos. Meas. Tech.* 8, 1575– 1591.

Venterea, R.T.; Clough, T.J.; Coulter, J.A.; Breuillin-Sessoms, F.; Wang, P.; Sadowsky, M.A. (2015) Ammonium sorption and ammonia inhibition of nitrite-oxidizing bacteria explain contrasting soil N₂O production. *Sci. Rep.* 5, 12153.

Vogeler, I.; Cichota, R.; Snow, V.O.; Dutton, T.; Daly, B. 2010. Pedotransfer functions for estimating ammonium adsorption in soils. *Soil Sci. Soc. Am. J.* 75, 324 – 331.

Walker, J.T.; Robarge, W.P.; Wu, Y.; Meyers, T. (2006) Measurement of bi-directional ammonia fluxes over soybean using the modified Bowen-ratio technique. *Agric. Forest Meteorol.* 138, 54-68.

Walker, J.T.; Jones, M.R.; Bash, J.O.; Myles, L.; Meyers, T.; Schwede, D.; Herrick, J.; Nemitz, E.; Robarge, W. (2013) Processes of ammonia air-surface exchange in a fertilized *Zea mays* canopy. *Biogeosciences* 10, 981 - 998.

Zhang, L.; Wright, L.P.; Asman, W.A.H. (2010) Bi-directional air-surface exchange of atmospheric ammonia: A review of measurements and a development of a big-leaf model for applications in regional scale air-quality models. *J. of Geophys. Res.: Atmospheres* 115, D20310.

Zhu, L.; Henze, D.K.; Cady-Pereira, K.E.; Shephard, M.W.; Luo, M.; Pinder, R.W.; Bash, J.O.; Jeong, G.-R. (2013) Constraining U.S. ammonia emissions using TES remote sensing observations and the GEOS-Chem adjoint model. *J. Geophys. Res. Atmospheres* 118, 3355–3368.

Zhu, L.; Henze, D.; Bash, J.; Jeong, G.-R.; Cady-Pereira, K.; Shephard, M.; Luo, M.; Paulot, F.; Capps, S. (2015) Global evaluation of ammonia bidirectional exchange and livestock diurnal variation schemes. *Atmos. Chem. Phys.* 15, 12823-12843. doi:10.5194/acp-15-12823-2015

3.2.2. Development of in-canopy source/sink models that resolve deposition to ecosystem components (crown, understory, ground) and in-canopy chemistry

Rick Saylor¹ and Laurens Ganzeveld²

¹NOAA Air Resources Laboratory, Oak Ridge, TN

²Wageningen University and Research, Department of Environmental Sciences, Wageningen, the Netherlands

Research topic summary

Current state-of-the-science air quality and atmospheric chemistry-climate models use relatively simple parameterizations to represent the interaction of atmospheric gases and particles with vegetative canopies, ignoring or greatly simplifying the chemical, physical and biological complexity therein. Integrated surface-atmosphere exchange modules are needed to better represent this complexity in air quality and atmospheric chemistry models so that they can more accurately simulate within-canopy processes and resolve deposition to separate ecosystem components. This development will require close collaboration of modelers and field measurement scientists to design experiments dedicated to the improvement of these models. This is a high priority and will be a long-term research goal. The measurement campaigns would focus on prioritized knowledge gaps in the model and be driven by the largest uncertainties that can be identified by comparison to existing measurements, model sensitivity analyses, and intermodel comparisons. Initial intermodel comparisons are already in progress, but these efforts need to be expanded and sustained. As the updated models are developed and validated, the incorporation of these as modules into large-scale CTMs is an over-arching goal and would be pursued in the long-term.

Introduction

Parameterizations of surface-atmosphere exchange processes (i.e., emissions and dry deposition) used in current atmospheric chemistry and air quality models were developed in the 1970's-80's based on wind tunnel and field measurements made during those decades and earlier (Hicks et al., 2016). Because of the computational and measurement limitations of that time, as well as incomplete scientific understanding of near-surface processes and coarse horizontal model resolutions, the parameterizations were designed to simulate surface-atmosphere exchange in a relatively simple way. Physical, chemical and biological complexities of vegetative canopies were either ignored or encapsulated into whole-canopy

parameterizations that were convenient (and computationally inexpensive) approximations and adequate for the purposes of the CTMs of that time. In addition, emissions of biogenic components were treated separately from deposition processes, neglecting interactions of these processes within the canopy, and chemical exchange processes were largely independent of similar energy and water vapor exchange processes (Saylor and Hicks, 2016).

These simple parameterizations and the separation of emissions and deposition processes have not substantially changed or been updated in CTMs in the intervening decades, with the exception of some models attempting to simulate the bi-directional exchange of NH_3 (Pleim et al., 2013; Bash et al., 2013) and a canopy exchange model implemented in a global chemistry-climate modelling system to assess the role of canopy interactions in global soil NO_x emissions (Ganzeveld et al., 2002b) and to study the impact of land cover and land use changes on atmospheric chemistry-climate interactions (Ganzeveld et al., 2010). As measurement techniques and instrumentation have advanced, evidence has accumulated that many gaseous biogenic trace species (not only NH_3) exhibit bi-directional exchange with vegetation, with the direction of fluxes depending on local environmental and biological conditions (Kesselmeier, 2001; Rottenberger et al., 2004, 2005; Karl et al., 2005, 2010; Jardine et al., 2008, 2011; Park et al., 2013, 2014; Niinemets et al., 2014). At the landscape scale, both upward and downward fine particle fluxes above canopies are now routinely measured (Nemitz et al., 2004; Pryor et al., 2008; Vong et al., 2010; Gordon et al., 2011; Lavi et al., 2013, Pryor et al., 2013; Farmer et al., 2013; Deventer et al., 2015; Rannik et al., 2015), but current CTMs do not explicitly attempt to simulate canopy-level processes that would result in upward particle fluxes. Moreover, modern CTMs, mainly those used for regional scale air quality applications, now use much finer horizontal resolutions (3-4 km as compared to the 40-80 km of the 1980's) and will soon begin to approach the sub-kilometer range where land use and plant types may be more explicitly resolved, calling into question the adequacy of parameterizations that were developed and evaluated for grid cells consisting of a heterogeneous patchwork of land use types.

Given that surface-atmosphere exchange processes play critical roles in driving the chemical and physical behavior of the lower atmosphere and the deposition of chemical species, including Nr , to ecosystems, it is crucial that these processes be accurately represented in CTMs used for air quality, weather, climate or ecosystem change predictions. Additionally, evaluation of CTM simulations often relies on a direct comparison with surface layer observations, whose magnitude and temporal variability (diurnal, seasonal) are strongly controlled by surface-atmosphere exchange processes, requiring a realistic representation of these processes in the CTMs. Consequently, integrated surface-atmosphere exchange modules need to be developed that accurately account for interactions of biology, chemistry, turbulent transport, and multi-phase physics within vegetative canopies. Once these processes are adequately represented, CTMs will be more capable of simulating deposition of reactive nitrogen and other species to sensitive ecosystems and assessing potentially important feedback mechanisms as a function of long-term changes in weather, climate and land use.

State of the science

A variety of research groups have recognized the need to create canopy-level models and tools to improve scientific knowledge of surface-atmosphere exchange processes in and above vegetative canopies and ultimately enhance the representation of these processes in CTMs. Early efforts, which mainly focused on the development and use of field-scale canopy exchange modeling systems, included the work of Gao et al. (1993), Gao and Wesely (1994) and Doskey and Gao (1999) to assess the impact of within-canopy processes on the oxidation of isoprene and alpha-pinene from temperate forests. Makar et al. (1999) and Stroud et al. (2005) extended the assessment to other BVOCs including mono- and sesqui-terpenes. Other similar efforts have included Stockwell and Forkel (2002), Forkel et al. (2006) and Bryan et al. (2012). Common features of these investigations include multi-layer one-dimensional models treating simplified gas-phase chemical mechanisms, first-order turbulence closure approximations (except for Gao and Wesely, 1994), and a focus on how and by how much gas-phase chemical transformations are reduced within the canopy environment.

More recent efforts, including Mogensen et al. (2011), Boy et al. (2011), Wolfe and Thornton (2011), Wolfe et al. (2011a), Wolfe et al. (2011b), and Saylor (2013), have examined how the inclusion of more realistic gas-phase chemical mechanisms (derived from the Master Chemical Mechanism at the University of Leeds; Saunders et al., 2003) might impact conclusions of the earlier work. A few of the most recent efforts (e.g., Zhou et al., 2014; Ashworth et al., 2015) have begun to include dynamic aerosol processes in these models to investigate the formation and growth of particles in the canopy environment. Anticipating the implementation of these kinds of modules into large-scale CTMs, Ganzeveld et al. (2002a and b) developed a multi-layer canopy exchange model for incorporation into a global chemistry-climate modeling system. The enhanced CTM was evaluated with simulations of O₃, NO_x and isoprene for multiple ecosystems using a 1-D version of the chemistry-climate system (Ganzeveld et al., 2002a). Implementation of the exchange module into a global model was then performed to study the role of canopy interactions in global atmosphere-biosphere NO_x exchange (Ganzeveld et al. 2002b).

From the perspective of Nr exchange, canopy models with full treatment of atmospheric chemical transformation processes are necessary to fully simulate and ultimately understand atmosphere-biosphere exchange of NO_x, as well as NO_y, organic nitrates and particle nitrate over vegetated landscapes. On the other hand, simulation of the deposition of reduced nitrogen species, and in particular NH₃, may not require full chemistry treatments since these species have only limited interactions with photochemical cycles, but may still benefit from more detailed simulation of the physics of the canopy environment. To date, most NH₃ deposition (i.e., bi-directional exchange) models have primarily used the “big-leaf” framework and have not attempted to vertically resolve processes of canopy exchange beyond the two-layer approach of Nemitz et al. (2001) (e.g., Nemitz et al., 2004; Walker et al., 2008; Personne et al., 2009; Zhang et al., 2010; Pleim et al., 2013; Walker et al., 2013). One exception is the

work of Bash et al. (2010) where an analytical model was formulated to describe the vertical profiles of sources, sinks, concentrations and fluxes of NH_3 in a maize canopy. Bash et al. (2010) were able to demonstrate that even with their simple model significant insights can be gained into the overall processes controlling the ability of the canopy to act as a source or sink for NH_3 emitted from the soil surface.

Future research

It seems clear that development of multi-layer, within-canopy chemistry and physics models will continue with specific model developments and applications focused on answering particular science questions. Overall, modeling efforts will continue towards the goal of the creation of integrated surface-atmosphere exchange modules that provide enough detail to represent faithfully the interactions and feedbacks among the most important biological, chemical and physical processes within the canopy. These comprehensive, integrated models, in conjunction with detailed within-canopy measurement programs, will help advance the understanding of surface-atmosphere exchange processes. Such models will be useful on their own in field-scale analyses of observations, but the increased scientific understanding gained from these efforts can then be translated to large-scale CTMs either via modifications of current parameterizations or by the wholesale incorporation of surface-atmosphere exchange modules into the CTMs (already initially accomplished by Ganzveld et al., 2002a, 2002b). In the latter case, the modules may need to be downscaled or condensed or streamlined computationally so that they are viable for meaningful CTM applications. To get from the current state of these models to such viability in CTMs will require several research advances.

Model Development. Future model development will continue to include the incorporation or enhancement of relevant physical, chemical and biological processes that may be important for accurate simulation of surface-atmosphere exchange. Models will continue to incorporate aerosols into their frameworks, including aerosol formation and dynamics, which are likely quite different within canopies (e.g., higher BVOC concentrations, higher humidity, lower temperature, attenuated actinic fluxes, suppressed turbulent mixing) than in full sun, non-canopy environments. By including these processes, the models will be better able to simulate recent observations of bi-directional aerosol fluxes above forest canopies. The models will also need to move towards more biologically-based canopy and soil/surface processes and away from empirically-derived parameterizations. Examples include BVOC emissions/uptake and leaf exchange rates linked more directly to photosynthetic assimilation rates (Grote et al., 2014) and soil/surface exchange linked to microbial activity and soil chemistry (Smith et al., 2003; Peñuelas, et al., 2014), and simulation of feedbacks on exchange processes imposed by prior pollutant uptake or deposition. Doing so will help facilitate the treatment of bi-directional biosphere-atmosphere exchange that seems to be the rule rather than the exception (Niinemets et al., 2014) and provides the models with greater capability in simulating processes impacted by global change. Models must also be capable of accurately simulating the turbulent

fluxes of gases and aerosols over vegetative canopies, where measurements have demonstrated that much of the vertical transport in and out of the canopy is dominated by coherent structures and intermittency (Thomas et al., 2013; Steiner et al., 2011), rather than transport as is typically approximated with simple gradient transport theory (Bryan et al., 2012).

Model Evaluation. As models incorporate more complex processes, the need grows ever greater for evaluations of model predictions to ensure realistic behavior and the accuracy of simulated responses to changes in forcing environmental conditions. Research to perform these evaluations would take advantage of measurements of opportunity (e.g., the Southern Oxidant and Aerosol Study; Xu et al., 2015), but field measurement campaigns dedicated to improving these models will also be necessary. This would require the close collaboration of modelers and field measurement scientists (including the research communities of atmospheric chemistry, micrometeorology, hydrology, biogeochemistry and plant ecology) and ideally would occur over a variety of canopies (crops, evergreen-, deciduous-, or mixed-forests) and across seasons and phenological variation. An important component of model evaluation also includes intermodel comparisons. An initial effort of this kind called CANEXMIP (Canopy Exchange Model Intercomparison Project) has been created as a joint initiative of Future Earth's iLEAPS (Integrated Land Ecosystem-Atmosphere Processes Study; <http://www.ileaps.org/> accessed October 5, 2018) and GEIA (the Global Emissions Initiative; <http://www.geiacenter.org/> accessed October 5, 2018). CANEXMIP currently has active involvement from several canopy modeling research groups around the globe and plans future collaborative workshops to compare model predictions of deposition and emissions fluxes for a variety of sites with contrasting climate and environmental conditions. Support for individual research groups' participation in CANEXMIP is critical for the advancement of the science and efficacy of these models.

Computational Advances. Incorporating advanced surface-atmosphere exchange models into CTMs will likely increase the computational burden of large-scale simulations. Computational science research will thus be needed to develop techniques or tools to downscale or condense comprehensive surface-atmosphere exchange models down to computationally viable modules appropriate for inclusion into CTMs. This might be accomplished via (i) streamlining the model to account only for the processes determined (by comprehensive model evaluations) to have a significant impact on regional- or meso-scale prognostic variables; (ii) the use of machine learning technologies to create "black-box" modules that mimic the behavior of comprehensive models but are less computationally costly; or, (iii) the use of new computational hardware (e.g., graphical processing units – GPUs) and/or new numerical techniques to compute sub-grid scale surface-atmosphere exchange processes.

CTM Incorporation and Evaluation. Once the science of surface-atmosphere exchange modules has matured and computationally appropriate techniques or modules have been developed, research will be needed to fully evaluate the new modules after their incorporation into CTMs. Large-scale evaluations of the upgraded CTMs against data from field measurement campaigns

will be needed to validate overall model accuracy. Moreover, it may be necessary to carry out new field experiments with measurements explicitly designed to evaluate the enhanced physical, chemical and biological processes that are predicted by the new CTMs. Given the fact that such developments would allow a more realistic representation of surface-atmosphere exchange processes at the larger-scale, e.g. at the grid resolution of the CTMs, one would also need to consider how to further develop or apply measurements that provide information about exchange fluxes at such scales, e.g. from remote sensing measurement technology.

Although the effort and resources required to implement an enhanced representation of surface-atmosphere exchange in CTMs is large, the benefit in improving CTM predictions of these processes is significant and potentially critical to improving future high-resolution predictions of deposition, ecosystem change, air quality, weather and climate.

References

- Ashworth, K., Chung, S. H., Griffin, R. J., Chen, J., Forkel, R., Bryan, A. M., and Steiner, A. L. (2015) FORest Canopy Atmosphere Transfer (FORCAST) 1.0: a 1-D model of biosphere-atmosphere chemical exchange, *Geoscientific Model Development*, 8, 3765-3784.
- Bash, J. O., Walker, J. T., Katul, G. G., Jones, M. R., Nemitz, E., and Robarge, W. P. (2010) Estimation of in-canopy ammonia sources and sinks in a fertilized Zea mays field, *Environmental Science and Technology*, 44, 1683-1689.
- Bash, J. O., Cooter, E. J., Dennis, R. L., Walker, J. T., and Pleim, J. E. (2013) Evaluation of a regional air-quality model with bidirectional NH₃ exchange coupled to an agroecosystem model, *Biogeosciences*, 10, 1635-1645.
- Boy, M., Sogachev, A., Lauros, J., Zhou, L., Guenther, A., and Smolander, S. (2011) SOSA – a new model to simulate the concentrations of organic vapours and sulphuric acid inside the ABL – Part 1: Model description and initial evaluation, *Atmospheric Chemistry and Physics*, 11, 43-51.
- Bryan, A. M., Bertman, S. B., Carroll, M. A., Dusanter, S., Edwards, G. D., Forkel, R., Griffith, S., Guenther, A. B., Hansen, R. F., Helmig, D., Jobson, B. T., Keutsch, F. N., Lefer, B. L., Pressley, S. N., Shepson, P. B., Stevens, P. S., and Steiner, A. L. (2012) In-canopy gas-phase chemistry during CABINEX 2009: sensitivity of a 1-D canopy model to vertical mixing and isoprene chemistry, *Atmospheric Chemistry and Physics Discussions*, 12, 12801-12852.
- Deventer, M. J., El-Madany, T., Griessbaum, F. and Klemm, O. (2015) One-year measurement of size-resolved particle fluxes in an urban area, *Tellus*, 67B, 25531, doi:10.3402/tellusb.v67.25531.
- Doskey, P. V., and Gao, W. (1999) Vertical mixing and chemistry of isoprene in the atmospheric boundary layer: Aircraft-based measurements and numerical modeling, *Journal of Geophysical Research*, 104, 21263-21274.

Farmer, D. K., Chen, Q., Kimmel, J. R., Docherty, K. S., Nemitz, E., Artaxo, P. A., Cappa, C. D., Martin, S. T., and Jimenez, J. L. (2013) Chemically resolved particle fluxes over tropical and temperate forests, *Aerosol Science and Technology*, 47, 818-830.

Forkel, R., Klemm, O., Graus, M., Rappengluck, B., Stockwell, W. R., Grabmer, W., Held, A., Hansel, A., and Steinbrecher, R. (2006) Trace gas exchange and gas phase chemistry in a Norway spruce forest: A study with a coupled 1-dimensional canopy atmospheric chemistry emission model, *Atmospheric Environment*, 40, S28-S42.

Ganzeveld, L., J. Lelieveld, F. J. Dentener, M. C. Krol, and G.-J. Roelofs (2002a) Atmosphere-biosphere trace gas exchanges simulated with a single-column model, *Journal of Geophysical Research*, 107, 2002a.

Ganzeveld, L., J. Lelieveld, F. J. Dentener, M. C. Krol, A. F. Bouwman, and G.-J. Roelofs (2002b) The influence of soil-biogenic NO_x emissions on the global distribution of reactive trace gases: the role of canopy processes, *Journal of Geophysical Research*, 107.

Ganzeveld, L., Lex Bouwman, Elke Stehfest, Detlef P. van Vuuren,, Bas Eickhout, and Jos Lelieveld (2010) The impact of Future Land Use and Land Cover Changes on Atmospheric Chemistry-Climate Interactions, *Journal of Geophysical Research*, 115, doi:10.1029/2010jd014041.

Gao, W., Wesely, M. L., and Doskey, P. V. (1993) Numerical modeling of the turbulent diffusion and chemistry of NO_x, O₃, isoprene, and other reactive trace gases in and above a forest canopy, *Journal of Geophysical Research*, 98, 18,339-18,353.

Gao, W., and Wesely, M. L. (1994) Numerical modeling of the turbulent fluxes of chemically reactive trace gases in the atmospheric boundary layer, *Journal of Applied Meteorology*, 33, 835-847.

Gordon, M., Staebler, R. M., Liggio, J., Vlasenko, A., Li, S.-M., and Hayden, K. (2011) Aerosol flux measurements above a mixed forest at Borden, Ontario, *Atmospheric Chemistry and Physics*, 11, 6773-6786.

Grote, R., Morfopoulos, C., Niinemets, U., Sun, Z., Keenan, T. F., Pacifico, F. and Butler, T. (2014) A fully integrated isoprenoid emissions model coupling emissions to photosynthetic characteristics, *Plant, Cell and Environment*, 37, 1965-1980.

Hicks, B. B., Saylor, R. D., and Baker, B. D. (2016) Dry deposition of particles to canopies – A look back and the road forward, *Journal of Geophysical Research-Atmospheres*, 121, doi:10.1002/2015JD024742.

Jardine, K., Harley, P., Karl, T., Guenther, A., Lerdau, M., and Mak, J. E. (2008) Plant physiological and environmental controls over the exchange of acetaldehyde between forest canopies and the atmosphere, *Biogeosciences*, 5, 1559-1572.

Jardine, K., Yanez Serrano, A., Arneth, A., Abrell, L., Jardine, A., Artaxo, P., Alves, E., Kesselmeier, J., Taylor, T., Saleska, S., and Huxman, T. (2011) Ecosystem-scale compensation points of formic and acetic acid in the central Amazon, *Biogeosciences*, 8, 3709-3720.

Karl, T., Harley, P. C., Guenther, A., Rasmussen, R., Baker, B., Jardine, K. and Nemitz, E. (2005) The bi-directional exchange of oxygenated VOCs between a loblolly pine (*Pinus taeda*) plantation and the atmosphere, *Atmospheric Chemistry and Physics*, 5, 3015-3031.

Karl, T., Harley, P., Emmons, L., Thornton, B., Guenther, A., Basu, C., Turnipseed, A., and Jardine, K. (2010) Efficient atmospheric cleansing of oxidized organic trace gases by vegetation, *Science*, 330, 816-819.

Kesselmeier, J. (2001) Exchange of short-chain oxygenated volatile organic compounds (VOCs) between plants and the atmosphere: a compilation of field and laboratory studies, *Journal of Atmospheric Chemistry*, 39, 219-233.

Lavi, A., Farmer, D. K., Segre, E., Moise, T., Rotenberg, E., Jimenez, J. L., Rudich, Y. (2013) Fluxes of fine particles over a semi-arid pine forest: Possible effects of a complex terrain, *Aerosol Science and Technology*, 47, 906-915.

Makar, P. A., Fuentes, J. D., Wang, D., Staebler, R. M., and Wiebe, H. A. (1999) Chemical processing of biogenic hydrocarbons within and above a temperate deciduous forest, *Journal of Geophysical Research*, 104, D3, 3581-3603.

Mogensen, D., Smolander, S., Sogachev, A., Zhou, L., Sinha, V., Guenther, A., Williams, J., Nieminen, T., Kajos, M. K., Rinne, J., Kulmala, M., and Boy, M. (2011) Modelling atmospheric OH-reactivity in a boreal forest ecosystem, *Atmospheric Chemistry and Physics*, 11, 9709-9719.

Nemitz, E., Milford, C., and Sutton, M. A. (2001) A two-layer canopy compensation point model for describing bi-directional biosphere-atmosphere exchange of ammonia, *Quarterly Journal of the Royal Meteorological Society*, 127, 815-833.

Nemitz, E., Sutton, M. A., Wyers, G. P., and Jongejan, P. A. C. (2004) Gas-particle interactions above a Dutch heathland: I. Surface exchange fluxes of NH₃, SO₂, HNO₃ and HCl, *Atmospheric Chemistry and Physics*, 4, 989-1005.

Niinemets, U., Fares, S., Harley, P. and Jardine, K. (2014) Review: Bidirectional exchange of biogenic volatiles with vegetation: emission sources, reactions, breakdown and deposition, *Plant, Cell and Environment*, 37, 1790-1809.

Park, J.-H., Goldstein, A. H., Timkovsky, J., Fares, S., Weber, R., Karlik, J., and Holzinger, R. (2013) Active atmosphere-ecosystem exchange of the vast majority of detected volatile organic compounds, *Science*, 341, 643-647.

Park, J.-H., Fares, S., Weber, R., and Goldstein, A. H. (2014) Biogenic volatile organic compound emissions during BEARPEX 2009 measured by eddy covariance and flux-gradient similarity methods, *Atmospheric Chemistry and Physics*, 14, 231-244.

Peñuelas, J., Asensio, D., Tholl, D., Wenke, K., Rosenkranz, M., Piechulla, B., Schnitzler, J. P. (2014) Biogenic volatile emissions from the soil, *Plant, Cell and Environment*, 37, 1866-1891.

Personne, E., Loubet, B., Herrmann, B., Mattsson, M., Schjoerring, J. K., Nemitz, E., Sutton, M. A., and Cellier, P. (2009) SURFATM-NH₃: a model combining the surface energy balance and bi-directional exchanges of ammonia applied at the field scale, *Biogeosciences*, 6, 1371-1388.

Pleim, J. E., Bash, J. O., Walker, J. T., and Cooter, E. (2013) Development and evaluation of an ammonia bidirectional flux parameterization for air quality models, *Journal of Geophysical Research-Atmospheres*, 118, doi:10.1002/jgrd.50262.

Pryor, S. C., Barthelmie, R. J., Sorensen, L. L., Larsen, S. E., Sempreviva, A. M., Gronholm, T., Rannik, U., Kulmala, M., and Vesala, T. (2008) Upward fluxes of particles over forests: when, where, why?, *Tellus*, 60B, 372-380.

Pryor, S. C., Barthelmie, R. J., and Hornsby, K. E. (2013) Size-resolved particle fluxes and vertical gradients over and in a sparse pine forest, *Aerosol Science and Technology*, 47, 1248-1257.

Rannik, U., Zhou, L., Zhou, P., Gierens, R., Mammarella, I., Sogachev, A., and Boy, M. (2015) Aerosol dynamics within and above forest in relation to turbulent transport and dry deposition, *Atmospheric Chemistry and Physics Discussions*, 15, 19367-19403.

Rottenberger, S., Kuhn, U., Wolf, A., Schebeske, G., Olivia, S. T., Tavares, T. M., and Kesselmeier (2004) Exchange of short-chain aldehydes between Amazonian vegetation and the atmosphere, *Ecological Applications*, 14, S247-S262.

Rottenberger, S., Kuhn, U., Wolf, A., Schebeske, G., Olivia, S. T., Tavares, T. M., and Kesselmeier (2005) Formaldehyde and acetaldehyde exchange during leaf development of the Amazonian deciduous tree species *Hymenaea courbaril*, *Atmospheric Environment*, 39, 2275-2279.

Saunders, S. M., Jenkin, M. E., Derwent, R. G., and Pilling, M. J. (2003) Protocol for the development of the Master Chemical Mechanism, MCM v3 (Part A): tropospheric degradation of non-aromatic volatile organic compounds, *Atmospheric Chemistry and Physics*, 3, 161-180.

Saylor, R. D. (2013) The Atmospheric Chemistry and Canopy Exchange Simulation System (ACCESS): model description and application to a temperate deciduous forest canopy, *Atmospheric Chemistry and Physics*, 13, 693-715.

Saylor, R. D., and Hicks, B. B. (2016) New directions: Time for a new approach to modeling surface-atmosphere exchanges in air quality models?, *Atmospheric Environment*, 129, 229-233, doi:10.1016/j.atmosenv.2016.01.032.

- Smith, K. A., Ball, T., Conen, F., Dobbie, K. E., Massheder, J., and Rey, A. (2003) Exchange of greenhouse gases between soil and atmosphere: interactions of soil physical factors and biological processes, *European Journal of Soil Science*, 54, 779-791.
- Steiner, A. L., Pressley, S. N., Botros, A., Jones, E., Chung, S. H., and Edburg, S. L. (2011) Analysis of coherent structures and atmosphere-canopy coupling strength during the CABINEX field campaign, *Atmospheric Physics and Chemistry*, 11, 11921-11936.
- Stockwell, W. R., and Forkel, R. (2002) Ozone and volatile hydrocarbons: isoprene, terpenes, aldehydes, and organic acids. In: *Tree Physiology*, Vol. 3. Trace Gas Exchange in Forest Ecosystems, Gasche, R., Papen, H., Rennenberg, H. (eds.), Kluwer Academic Publishers, Dordrecht, pp. 257-276.
- Stroud, C., Makar, P., Karl, T., Guenther, A., Geron, C., Turnipseed, A., Nemitz, E., Baker, B., Potosnak, M., and Fuentes, J. D. (2005) Role of canopy-scale photochemistry in modifying biogenic-atmosphere exchange of reactive terpene species: Results from the CELTIC field study, *Journal of Geophysical Research*, 110, D17303, doi:10.1029/2005JD005775.
- Thomas, C. K., Martin, J. G., Law, B. E., and Davis, K. (2013) Toward biologically meaningful net carbon exchange estimates for tall, dense canopies: Multi-level eddy covariance observations and canopy coupling regimes in a mature Douglas-fir forest in Oregon, *Agricultural and Forest Meteorology*, 173, 14-27.
- Vong, R. J., Vong, I. J., Vickers, D., and Covert, D. S. (2010) Size-dependent aerosol deposition velocities during BEARPEX'07, *Atmospheric Chemistry and Physics*, 10, 5749-5758.
- Walker, J., Spence, P., Kimbrough, S., and Robarge, W. (2008) Inferential model estimates of ammonia dry deposition in the vicinity of a swine production facility, *Atmospheric Environment*, 42, 3407-3418.
- Walker, J., Jones, M. R., Bash, J. O., Myles, L., Meyers, T., Schwede, D., Herrick, J., Nemitz, E., and Robarge, W. (2013) Processes of ammonia air-surface exchange in a fertilized *Zea mays* canopy, *Biogeosciences*, 10, 981-998.
- Wolfe, G. M., and Thornton, J. A. (2011) The Chemistry of Atmosphere-Forest Exchange (CAFE) Model – Part 1: Model description and characterization, *Atmospheric Chemistry and Physics*, 11, 77-101.
- Wolfe, G. M., Thornton, J. A., Bouvier-Brown, N. C., Goldstein, A. H., Park, J. H., McKay, M., Matross, D. M., Mao, J., Brune, W. H., LaFranchi, B. W., Browne, E. C., Min, K.-E., Wooldridge, P. J., Cohen, R. C., Crouse, J. D., Faloon, I. C., Gilman, J. B., Kuster, W. C., de Gouw, J. A., Huisman, J., and Keutsch, F. N. (2011a) The Chemistry of Atmosphere-Forest Exchange (CAFE) Model – Part 2: Application to BEARPEX-2007 observations, *Atmospheric Chemistry and Physics*, 11, 1269-1294.

Wolfe, G. M., Thornton, J. A., McKay, M., and Goldstein, A. H. (2011b) Forest-atmosphere exchange of ozone: sensitivity to very reactive biogenic VOC emissions and implications for in-canopy photochemistry, *Atmospheric Chemistry and Physics*, 11, 7875-7891.

Xu, L., Guo, H., Boyd, C. M., Klein, M., Bougiatioti, A., Cerully, K. M., Hite, J. R., Isaacman-VanWertz, G., Kreisberg, N. M., Knote, C., Olson, K., Koss, A., Goldstein, A. H., Hering, S. V., de Gouw, J., Baumann, K., Lee, S.-H., Nenes, A., Weber, R. J., and Ng, N. L. (2015) Effects of anthropogenic emissions on aerosol formation from isoprene and monoterpenes in the southeastern United States, *Proceedings of the National Academy of Sciences*, 112, 37-42.

Zhang, L., Wright, L. P., and Asman, W. A. H. (2010) Bi-directional air-surface exchange of atmospheric ammonia: A review of measurements and a development of a big-leaf model for applications in regional-scale air-quality models, *Journal of Geophysical Research*, 115, D20310, doi:10.1029/2009JD013589.

Zhou, L., Nieminen, T., Mogensen, D., Smolander, S., Rusanen, A., Kulmala, M., Boy, M. (2014) SOSAA – a new model to simulate the concentrations of organic vapours, sulphuric acid and aerosols inside the ABL – Part 2: Aerosol dynamics and one case study at a boreal forest site, *Boreal Environment Research*, 19B, 237-256.

3.2.3. Modeling fluxes of Nr using chemical transport models

Donna Schwede¹, Havala O. T. Pye¹, Rick Saylor², Leiming Zhang³

¹U.S. EPA, Office of Research and Development, Durham, NC, 27711

²NOAA, Air Resources Laboratory, Oak Ridge, TN

³Environment and Climate Change Canada, Air Quality Research Division, 4905 Dufferin St., Toronto, ON

Research topic summary

Accurate representation of Nr fluxes in regional- to global-scale chemical transport models is important for development of deposition budgets. However, the magnitude and variability of Nr fluxes remain uncertain due to knowledge gaps that persist with respect to chemical processes driving atmospheric concentrations of Nr and parameterizations of air-surface exchange. The chemistry of the atmosphere is extremely complex and the task of comprehensively capturing that in a model is monumental. Current studies are improving our understanding and models are continually updated as that knowledge is incorporated. With this in mind, there are several important knowledge gaps in the representation of Nr fluxes in CTMs. These include improvement in model inputs, in atmospheric processing reactions for both chemical and phase transformations and air-surface exchange, and in model intercomparison studies to assess performance and to elucidate causes of uncertainty and variability that could potentially be addressed.

In this section, these knowledge gaps are described and cast as near-term or long-term needs based on the current state of the science. Emissions and meteorology are fundamental inputs to CTMs and uncertainties in these inputs propagate through the modeling system. Improvements in inventories of mobile NO_x emissions and NH₃ emissions from confined animal feeding operations are particularly needed with the latter representing a long-term effort.

Many of these knowledge gaps are linked. For instance, improving dust emissions inputs to properly account for cations in models will have an impact on gas-particle phase chemistry as better representation of nonvolatile cations will influence aerosol equilibrium modules and impact both oxidized and reduced Nr chemistry. Another area in need of continued work is the understanding of the chemistry and fate of organic nitrates and the parameters that drive N₂O₅ reactions.

With respect to dry deposition, process-level studies are needed to improve the representation of non-stomatal fluxes in CTMs. Exchange processes that happen at the cuticle and ground

surfaces need to be studied and exchange parameterizations developed that are less empirical than those derived from analysis of the residual canopy resistance. In this regard, incorporation of dew chemistry and volume could be incorporated into flux field studies in the near term. Better characterization of important model input parameters for NH_3 are needed, including, for example, the development of a database of emission potentials for a wide range of vegetation and soil types across North America. This type of “survey” work could be implemented in the near term.

In the absence of extensive measurement studies, model intercomparison studies serve to provide information on the uncertainty and variability of modeled deposition values and inform priorities for additional process-level measurements and monitoring. Model intercomparisons relevant to Nr deposition are ongoing (e.g., Air Quality Model Evaluation International Initiative (AQMEII)) and advances in this area can therefore be accomplished in the near term.

There are additional areas of research that represent long-term efforts. Air-surface exchange is a critical component of all atmospheric models, including those for weather, climate and air quality. There is a particular need for field studies that characterize the in- and near-canopy chemistry that impacts the net exchange of Nr with the atmosphere. This includes measurement of full chemical budgets to understand how NO_y and NH_x are cycling in the canopy air space, including interactions between BVOC and NO_x . Long term studies of air-surface exchange that span multiple seasons and years are needed to inform our understanding of the impact of changing weather and climate patterns, emissions control strategies, and plant stresses on deposition processes and trends. Finally, with respect to ON, the importance of amines in the total N deposition budget has not been firmly established. Improving the fundamental understanding of emissions, atmospheric chemistry, and deposition of amines represents a long-term research need.

Introduction

CTMs are an important tool for obtaining spatially resolved, consistent estimates of concentration and deposition of Nr species needed to support human health and ecological assessments. Model development relies on field and laboratory studies to develop parameterizations that represent the processes that control the chemistry and physics of the atmosphere. To the extent possible, CTMs try to represent processes using first principles, but limitations in our understanding of the processes as well as restrictions on computational efficiency sometimes require that empirical parameterizations and approximation are used instead. Models are continually being updated to reduce uncertainties in modeled values of concentration and deposition as new data reveals the relevant chemistry and physics.

Gas phase chemistry in CTMs is parameterized using chemical mechanisms. One of the most explicit chemical mechanisms is the Master Chemical Mechanism (Jenkin et al., 1997). To conserve runtime in CTMs, a condensed mechanism is often used where species with similar

chemical properties are lumped together and treated as one surrogate. Commonly used condensed mechanisms include Carbon Bond (CB) version 6, the Statewide Air Pollution Research Center-2007 (SAPRC-07), Regional Atmospheric Chemistry Mechanism (RACM), etc. Chemical mechanisms are modified as the importance of different chemical species and reactions are determined. Historically, chemical mechanisms have focused on reactions important in determining ozone concentrations. Recently, additional emphasis has been placed on the chemistry associated with N and S species, and, particularly, organic compounds including those that result from the reaction with biogenic compounds such as isoprene and monoterpenes. Characterization of gas-particle partitioning is also an important component of the chemistry included in CTMs. Capturing the complete cycling of the gas-particle system is important for determining atmospheric concentrations as well as deposition. For example, a recent study by Weber et al. (2016) examined the gas-particle system with respect to aerosol acidity and found surprising results. SO_2 and SO_4^{2-} emissions have been decreasing in the U.S. and Canada while NH_3 emissions have remained fairly constant. Looking at data from Southeastern U.S., Weber, et al. (2016) found that while the pH of rainwater has increased, the acidity of aerosols has not due to the buffering effect of the gas/particle partitioning of NH_3 .

Due to large reductions in emissions of S and NO_x and the unregulated nature of NH_3 in the U.S., the chemical composition of atmospheric Nr has changed significantly over the past few decades with implications for how models represent atmospheric Nr. Specifically, reduced Nr is increasing in importance relative to oxidized Nr, and ON is increasing relative to inorganic Nr. This shift from oxidized to reduced Nr has already been observed in ambient data as reduced Nr now often accounts for more than half of Nr deposition (Li et al., 2016). Decreasing NO_x emissions in the presence of VOCs, such as isoprene and monoterpenes from vegetation, also leads to increasing production of organic nitrates relative to nitric acid (Browne and Cohen, 2012; Fisher et al., 2016). Organic derivatives of NH_3 (amines) are relatively less studied and not usually considered in CTMs but come from many of the same unregulated sources as NH_3 including animal husbandry (Ge et al., 2011). This changing atmospheric composition requires the adaptation of CTM mechanisms.

Nr species can be exchanged between the atmosphere and Earth's surface by wet deposition or dry deposition. Wet deposition includes within-cloud and below-cloud scavenging. Correct prediction of wet deposition requires accurate values of the timing and amount of precipitation as well as the chemical specific solubility and scavenging coefficients. Deposition by fog can also be an important exchange process in some areas and is discussed in more detail in Section **3.1.1.6. Occult deposition: what we know, don't know, and should really know**. Dry deposition of gases and particles depends on the turbulence of the atmosphere, the characteristics of the surface, the properties of chemical species (gases), and particle size (aerosols). Some species, such as NH_3 , exchange bidirectionally with the surface with the direction of exchange being dependent primarily on the concentrations in the atmosphere and the soil and vegetation. Flux measurements made during intensive field studies (see Section **3.1.1.1. Measurements of air-**

surface exchange of Nr in natural ecosystems across North America) are used to develop parameterizations of these processes at the field scale which are then adapted for use in CTMs.

There are many CTMs and modeling systems used across the globe. The choice of meteorological model, emissions, chemical transport model, model inputs, and model options can lead to different predicted values of deposition. Several recent model intercomparison studies have begun to examine Nr and S deposition values. In these intercomparison studies, emissions are consistent between models while meteorological inputs may vary. Vivanco et al. (2018) examined data from 14 CTMs that participated in the AQMEII3 and EURODELTAIII regional-scale modeling projects and found large differences between the models, particularly for dry deposition. Model evaluations were performed only for wet deposition and air concentrations, since little data is available for evaluation of dry deposition values from CTMs. Wet deposition was found to be mostly underpredicted by the models. Using data from 11 global-scale models that participated in HTAP2, Tan et al. (2018) also found a large differences in global deposition of Nr with values ranging from 11 to 19 Tg-N yr⁻¹. While extremely useful, none of the model intercomparison studies to date has provided enough information to understand which of the deposition model components drives the differences. The AQMEII4, to be launched in 2019, will collect this needed information and will provide a unique opportunity to make detailed comparisons of deposition algorithms used in CTMs.

In the sections that follow, the state of science of atmospheric chemistry and air-surface exchange of gases and particles implemented in commonly used CTMs will be reviewed with an emphasis on the areas of recent scientific advances and the areas with greatest uncertainty. A summary of near-term and long-term research needed to advance the models and reduce uncertainties is provided.

State of the science

Atmospheric chemistry

Atmospheric chemistry in CTMs is modeled holistically where emissions, gas-phase chemistry, PM formation, deposition, and transport of all chemical species are coupled together. To facilitate the discussion of key uncertainties relative to Nr, the discussion below will focus first on oxidized Nr by examining the representation of the NO_y system and, secondly, on the reduced Nr system NH_x. Gas/particle partitioning and interactions are an important part of both chemical systems.

Oxidized nitrogen (NO_y)

While most oxidized Nr is emitted in the form of NO_x (NO_x = NO + NO₂), oxidized Nr in the atmosphere exists in many chemical and physical forms as illustrated in Figure 1. This collection of species in which the oxidation state of N is +2 or greater is called NO_y (<https://www3.epa.gov/ttnamti1/files/ambient/pm25/spec/noysum2.pdf>). In general, total

NO_y in the gas and particle phases can be determined from the sum of nitrogen oxides (NO_x), nitrate radicals (NO₃), dinitrogen pentoxide (N₂O₅), HONO, HNO₃, HNO₄, nitrophenols and nitrocresols (NPHE), nitril chloride (ClNO₂), PAN, organic nitrates (NTR), and particulate nitrate (NO₃⁻):

$$\text{NO}_y = \text{NO}_x + \text{NO}_3 + 2 \times \text{N}_2\text{O}_5 + \text{HONO} + \text{HNO}_3 + \text{HNO}_4 + \text{NPHE} + \text{ClNO}_2 + \text{PAN} + \text{NTR} + \text{NO}_3^- \quad (1)$$

The PAN and NTR components of NO_y include multiple species and are usually represented in models by a limited number of surrogates. In CMAQ (www.epa.gov/cmaq) with Carbon Bond 6 revision 3 chemistry (CB6r3, (Emery et al., 2015)), the most commonly used mechanism for regulatory work, organic nitrates are represented using three surrogates whose Henry's law coefficients span 4 orders of magnitude from 0.65 to 6,500 M atm⁻¹. PAN is also represented with three different surrogates, but with less than a factor of 2 variability in solubility across the group. Alternatively, in the more detailed SAPRC mechanism (Carter, 2010) with expanded isoprene chemistry (SAPRC07tic)(Xie et al., 2013; Pye et al., 2015), five peroxyacyl nitrates and twelve different types of organic nitrates are explicitly represented to better capture recycling of NO_x and secondary organic aerosol formation in isoprene-rich regions.

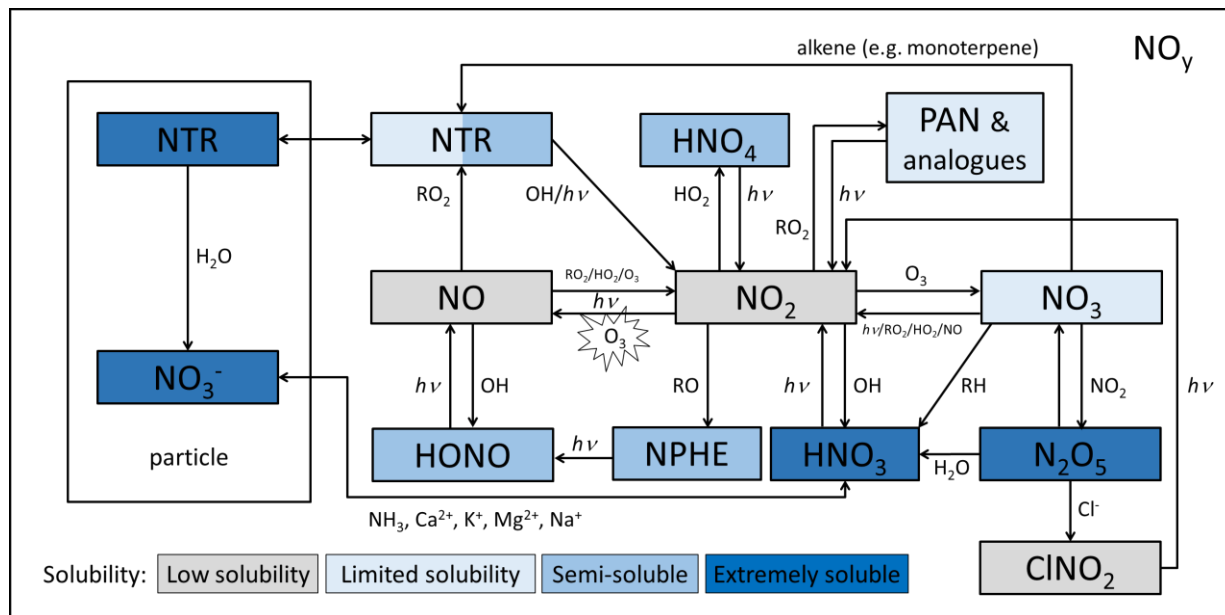

Figure 1. Representation of the NO_y chemical system as implemented in a model such as CMAQ. Species are classified by their Henry's law coefficient in CMAQ as low solubility (< 0.1 M atm⁻¹ at 298.15 K), limited solubility (0.1 to 10 M atm⁻¹), semi-soluble (10 to 10⁴ M atm⁻¹), and extremely soluble (>10⁴ M atm⁻¹) species. Particulate forms of nitrate are classified as

extremely soluble assuming complete solubilization in clouds. $h\nu$ represents photolysis reactions. Schematic adapted from Seinfeld and Pandis (1998).

Regardless of how many species are represented in a mechanism, all chemical mechanisms convert relatively insoluble NO_x emissions to a variety of products based on the presence of VOCs, oxidant levels, and light necessary for photolysis. As such, the composition of NO_y varies in time and space. NO_y species may serve as terminal or temporary reservoirs of atmospheric Nr depending on whether they deposit or regenerate NO_x. The rate at which Nr is removed from the atmosphere via deposition depends on the chemical mechanism as different mechanisms make different assumptions (e.g. the yield and fate of organics nitrates) that result in different estimates of NO_y magnitude and composition (Luecken et al., 1999; Sarwar et al., 2013).

In the remainder of this section, several uncertainties in NO_y modeling are highlighted for their potential to affect model estimates of oxidized nitrogen deposition: biases in gas-particle partitioning, fate of organic nitrates, rate of N₂O₅ hydrolysis, and uncertainty in NO_x emissions.

Both organic nitrates and total inorganic nitrate (HNO₃+NO₃⁻) can exist in the particle and gas phases. For organic nitrate, the partitioning will be dictated by the vapor pressure, solubility, and particle-phase reactivity of the species. For inorganic nitrate, gas-particle partitioning is usually determined assuming equilibrium between the gases and fine aerosol using a thermodynamic model such as ISORROPIA (Fountoukis and Nenes, 2007). Nitrate partitioning toward the particle-phase will be facilitated by nonvolatile cations (calcium, potassium, magnesium, and sodium) as well as NH₃ (Fountoukis and Nenes, 2007). As a result, overestimates in nonvolatile cations, which has been noted in the CMAQ model (Appel et al., 2013; Pye et al., 2018) can lead to overestimates in particulate nitrate (Vasilakos et al., 2018). Since particulate forms of Nr will be less efficiently deposited than gas-phase forms of highly soluble Nr, gas-particle partitioning biases have implications for deposition. Thermodynamic models are generally considered to provide a good representation of gas-particle partitioning (Guo et al., 2017; Pye, et al., 2018), so the equilibrium model inputs, in terms of total nitrate, total ammonia, sulfate, and nonvolatile cations, are critical to constrain in CTMs to accurately reproduce particulate nitrate and NH₄⁺.

One of the more uncertain aspects of gas-phase NO_y chemistry in summer is the fate of organic nitrates which may include photolysis, deposition, oxidation, partitioning to the particulate phase, and/or hydrolysis. These processes have dramatic differences in terms of their implications for ozone, PM formation, and deposition as photolysis converts N back to NO_x and hydrolysis results in HNO₃. Historically (e.g. CMAQ v5.0.2 released in 2014 and prior), hydrolysis of organic nitrates on or in particles was not considered by models, but recent work indicates organic nitrates contribute to secondary organic aerosol (SOA) formation ((Lee et al., 2016; Ng et al., 2017) (Xu et al., 2015), have short particle-phase lifetimes (Lee, et al., 2016), and could be

largely lost to HNO₃ via heterogeneous hydrolysis (Fisher, et al., 2016). SAPRC- and RACM-based mechanisms do not explicitly include hydrolysis of organic nitrates.

In winter, N₂O₅ hydrolysis to HNO₃ controls the lifetime of NO_x (Kenagy et al., 2018). However, parameters currently in use by chemical transport models general fail to capture the range of atmospherically relevant N₂O₅ reaction probabilities and often overpredict the conversion of N₂O₅ to HNO₃ (McDuffie et al., 2018).

Another source of uncertainty in predicting NO_y and its deposition are emission inventories. Recent studies have suggested that the NO_x emissions in the U.S. EPA NEI, particularly from the mobile sector in summer, may be overestimated (McDonald et al., 2012; Anderson et al., 2014; McDonald et al., 2018). Overestimates in NO_x result in overestimates in the downstream NO_y species and oxidized Nr deposition (Travis et al., 2016).

Reduced nitrogen (NH_x)

The reduced Nr system, collectively referred to as NH_x, consists of NH₃, NH₄⁺, and amines. CTMs usually include the inorganic forms of NH_x, but most do not include amines. NH₃ is considered nonreactive in most gas-phase chemical mechanisms but can partition to the particle phase as NH₄⁺ with implications for particulate acidity and nitrate partitioning as well as deposition (Weber et al., 2016). Current thermodynamic models reasonably predict the partitioning of NH₃ and NH₄⁺ between the gas and aerosol phase (Guo, et al., 2017; Pye, et al., 2018). However, nonvolatile cation biases in CTMs, such as those mentioned earlier, have been shown to displace NH₄⁺ from the particle. With accurate nonvolatile cation abundances, current thermodynamic equilibrium assumptions applied in the U.S. generally reproduce nitrate and NH₃ partitioning (Guo, et al., 2017; Pye, et al., 2018) and are not considered the primary source of uncertainty for total NH_x.

The role of amines in contributing to atmospheric reduced Nr and deposition is not well established. These organic reduced Nr compounds are generally not represented in models but are recognized contributors to the organic component of PM_{2.5} and nucleation events. Wet scavenging of gas-phase amines is thought to be the main source of amines in deposition (Ge, et al., 2011). Amines can be emitted by sources such as animal husbandry, industrial processes and wildland fires (Ge, et al., 2011; Kuhn et al., 2011; Sintermann et al., 2014). Amines can also react in the atmosphere with HNO₃ and H₂SO₄ to form salts (Murphy et al., 2007). Recent research is also focusing on understanding the role of amines in new particle formation (Yu et al., 2012; Almeida et al., 2013) and in the formation of SOA (Murphy, et al., 2007; Price et al., 2014) and developing chemical mechanisms to describe the atmospheric chemistry so that their importance to deposition may be better understood.

The major source of uncertainty in current modeling of the NH_x system stems from challenges associated with representing surface exchange including both emissions and deposition. NH₃, with a Henry's Law coefficient of 61 M atm⁻¹ at 298.15K, is significantly less soluble than HNO₃ but more soluble than emitted oxidized Nr. Unlike most oxidized Nr species that

unidirectionally deposit to the surface, NH₃ exchanges bidirectionally depending on the relative concentrations in the air, plant tissue, and soil. NH₃ is emitted from many sources including wildfires, mobile sources, and stationary sources such as confined animal feeding operations (CAFOs) and fertilizer application with the bulk of emissions being due to agricultural operations (<https://gispub.epa.gov/neireport/2014/>). Since NH₃ emissions are not regulated by the EPA, models are used to develop emissions estimates. There is ongoing work to update the models for animal feeding operations as part of the National Air Emissions Monitoring Study (NAEMS) (<https://www.epa.gov/afos-air/national-air-emissions-monitoring-study>). Fertilizer application and soil emission potential can be modeled using an agricultural management model such as the Environmental Policy Integrated Climate (EPIC) model (<https://blackland.tamu.edu/models/epic/>). NH₃ emission from croplands is strongly impacted by crop type, land management techniques (e.g. fertilizer application methods, tilling), and meteorology (Cooter et al., 2012; Bash et al., 2013; Pleim et al., 2013). Efforts with bidirectional NH₃ exchange in models indicate capturing the diurnal variation of the exchange remains challenging (Pleim, et al., 2013; Lonsdale et al., 2017).

Air-surface exchange processes

Nr species can be exchanged between the atmosphere and Earth's surface by wet deposition or dry deposition. Dry deposition of gases and particles can occur due to transport from atmospheric turbulence and from interactions with the underlying surface. Meteorology and surface characteristics play an important role in determining dry deposition. Dry deposition (of both gases and particles) is notoriously difficult to measure accurately (Hicks, 1986); and, since it is not a spatially ergodic process, a dry deposition flux measured at one location under one set of conditions may not necessarily be representative of another similar location and set of conditions (Hicks, 1995). As a result, CTMs are routinely used to estimate dry deposition fluxes for environmental assessments through the fusion of measurements and model results (Ellis et al., 2013; Schwede and Lear, 2014).

Wet deposition includes within-cloud and below-cloud scavenging. Wet deposition predictions will be controlled by a model's ability to predict the atmospheric concentration and precipitation form and rate. Uptake or deposition by fog is covered in Section **3.1.1.6. *Occult deposition: what we know, don't know, and should really know*** and is not covered here. The following sections provide an overview of common approaches used in CTMs for calculating the air-surface exchange of gases and particles with an intent to highlight areas of greatest uncertainties relative to Nr deposition. It is beyond the scope of this white paper to provide a complete review of all deposition algorithms.

Dry deposition

Gases

There are many different models used in CTMs for calculating the exchange rate (i.e. deposition velocity, v_d) of gases between the atmosphere and the surface. Many of the approaches use the

resistance paradigm (Wesely, 1989) which treats each pathway between the atmosphere as a set of resistances that act in series and parallel. The deposition velocity is calculated as

$$v_d = \frac{1}{R_a + R_b + R_s} \quad (2)$$

where R_a is the aerodynamic resistance, R_b is the quasi-laminar boundary layer resistance, and R_s is the surface resistance. R_s can be further subdivided into component resistances and is of the general form

$$R_s = \left(\frac{1}{R_{st}} + \frac{1}{R_w} + \frac{1}{R_g} \right)^{-1} \quad (3)$$

where R_{st} is the stomatal resistance, R_w is the cuticular resistance and R_g is the ground resistance. A schematic of the commonly used pathways or resistances is provided in Figure 2. An important consideration is the concentration of a given chemical in the underlying media (e.g. plant stomata, ground, leaf litter) which is denoted as the emission potential. Concentration gradients between the atmosphere and the media determine the direction of exchange. Most chemicals solely deposit from the atmosphere to the surface since the concentration in the underlying media is negligible compared to the atmospheric concentrations, but chemicals such as NH_3 which can have a high emission potential can evade from the media to the overlying atmosphere.

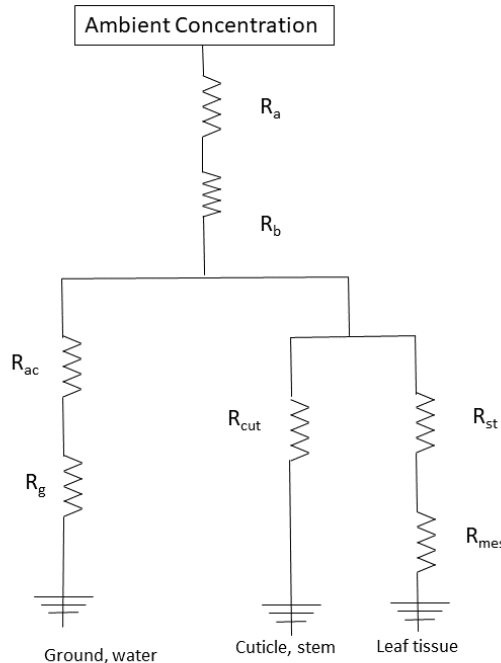

Figure 2. Resistance diagram for unidirectional exchange between the atmosphere and the surface.

Some of the air-surface exchange processes are fairly well understood. For example, the resistance due to atmospheric stability (R_a) is well parameterized using Monin-Obukhov similarity theory. There is still an evolving understanding of the boundary layer resistance and some approaches distinguish between values for soil (R_{bg}) and a leaf (R_{bl}). Specifying a leaf R_b requires a value for the characteristic leaf dimension which can be quite variable across plant species. Specifying a single value for a given land use type in a CTM is therefore challenging.

The surface resistance (R_s , equation 3) is an area of great uncertainty in deposition models. While the processes that control stomatal resistance (R_{st}) are fairly well understood, there is much less fundamental understanding of the exchange processes that occur in the mesophyll (R_{mes}) and at surfaces such as the cuticles and the ground. Often these resistances are parameterized from the residual (R_s) after aerodynamic, boundary layer, and stomatal resistances have been accounted for (equation 3). An additional resistance to account for the in-canopy turbulence (R_{ac}) is included in many models. As noted in Wu et al. (2018), parameterizations for these resistances are quite variable among the models which has an impact on the predicted deposition velocity. For both the cuticular resistance and the ground resistance, consideration must be given to the role of surface wetness. In early models, these surfaces were modeled as either wet or dry. Recent studies (Burkhardt and Hunsche, 2013) have shown that there can be microscopic layers of moisture on leaves that are thinner than a dew layer that are important in controlling the deposition of soluble chemical species. Some v_d algorithms attempt to include this affect by applying an empirically derived relative humidity

function to the dry cuticular or dry ground resistance. Parametrizations for wet cuticles or wet ground are also quite variable between models. For example, Zhang et al. (2003) includes consideration of the friction velocity based on Lamaud et al. (2009) while other models do not. Some models, such as CMAQ, use the Henry's Law constant to account for the solubility of the chemical species. The EMEP model (Simpson et al., 2012) considers the chemical content of dew by treating co-deposition of species such as SO_2 and NH_3 . There is a critical need to perform studies to improve the understanding of these exchange processes to reduce uncertainties in the parameterizations.

Another important aspect of Nr deposition is consideration of the bidirectional flux of NH_3 . Since NH_3 can be emitted or deposited, failure to consider the bidirectional flux can cause biases in modeled flux values. The bidirectional exchange of NH_3 is increasingly being included in some CTMs (Zhang et al., 2010; Wichink Kruit et al., 2012; Pleim, et al., 2013; Zhu et al., 2015), but there are numerous uncertainties associated with the parameterization. A commonly used framework for bidirectional modeling is the two-layer resistance model of Nemitz et al. (2001) (see Section 3.2.1. **Application of a bidirectional ammonia air-surface exchange model at NADP AMoN sites**) with updates to the cuticular resistance from Massad et al. (2010). A schematic of bidirectional exchange is shown in Figure 3.

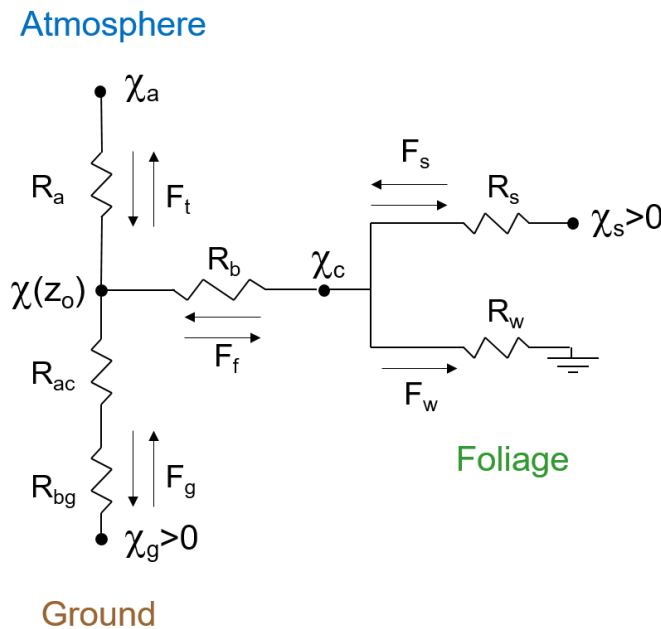

Figure 3. Two-layer foliage/ground resistance model of Nemitz, et al. (2001).

where X_a is the atmospheric concentration, X_c is the canopy compensation point, $X_{(z_0)}$ is the compensation point at the surface roughness height (Z_0), X_s is the stomatal compensation point, and X_g is the ground compensation point. Note that in this figure, R_s represents the stomatal resistance. F_t , F_f , F_s , F_w , and F_g are the fluxes to or from the total surface, foliage, stomates, cuticle, and ground. For this framework, the stomatal (χ_s) and ground (χ_g) compensation points

need to be specified. The compensation point is calculated from the temperature and the ratio of NH_4^+ to H^+ in the leaf apoplast of soil pore solution. The latter is referred to as the emission potential which is highly variable across not only media (soil, canopy) but also due to fertilization, cutting and many other processes. Sutton et al. (2009) found that emission potentials in Europe range over 4 orders of magnitude. While measurements for some vegetation types exist, they are not easily extrapolated to other ecosystems. Many of the measurements are from European ecosystems and may not be applicable to North America vegetation types and soil conditions. Additional measurements are a critical need to support NH_3 bidirectional flux modeling. A challenge for grid-based CTMs in modeling the bidirectional flux of NH_3 is the treatment of subgrid variations in land use. Within a grid cell, there may be some surface such as crop areas that emit NH_3 due to fertilization of the fields while other surfaces such as forests may experience deposition. There are a number of ways that this subgrid variability can be averaged to the grid level and each will result in a different net deposition. For example, emission potentials or compensation points may be averaged across the grid and then compared to the atmospheric concentration to determine the net flux. Alternately, the net flux for each subgrid land use type can be calculated and then area weighted to obtain the value for the grid. Either method neglects subgrid differences in concentration as emissions, transport, and deposition that may occur at the subgrid scale.

Aerosols

Dry deposition of particles is an important component of total Nr deposition, especially during periods or in locations with limited wet deposition. However, substantial differences in simulated particle deposition can occur between different CTMs (Solazzo et al., 2012; Im et al., 2015), likely arising from differences in the algorithms used to calculate particle deposition velocities. Most particle deposition velocity algorithms used in current CTMs have their heritage in the seminal work of Slinn (1982), but algorithms derived from it can produce widely differing deposition velocities under identical conditions (Khan and Perlinger, 2017), especially for accumulation mode (0.1-2.0 μm diameter) particles (see Figure 4). In addition to the inherent uncertainties of the different algorithm formulations, many of the input parameters to the algorithms (leaf dimension, leaf area index, land use category, roughness heights, etc.) are also highly uncertain. Moreover, as has been pointed out by numerous authors (Zhang and Vet, 2006; Petroff et al., 2008; Pryor et al., 2008; Hicks et al., 2016) most of the algorithms in CTMs describing the size-dependent dry deposition velocity of atmospheric particles over vegetative canopies do not agree very well with measurements, especially in the accumulation mode, and particularly for canopies with high surface roughness (i.e., forests). Potential explanations for these model-measurement discrepancies have been proposed (Pryor, et al., 2008), ranging from observational errors, to chemical flux divergences, faulty model assumptions, or the neglect of important deposition processes (e.g., turbophoresis, thermophoresis, etc.); however, the discrepancies remain and have not been definitively resolved.

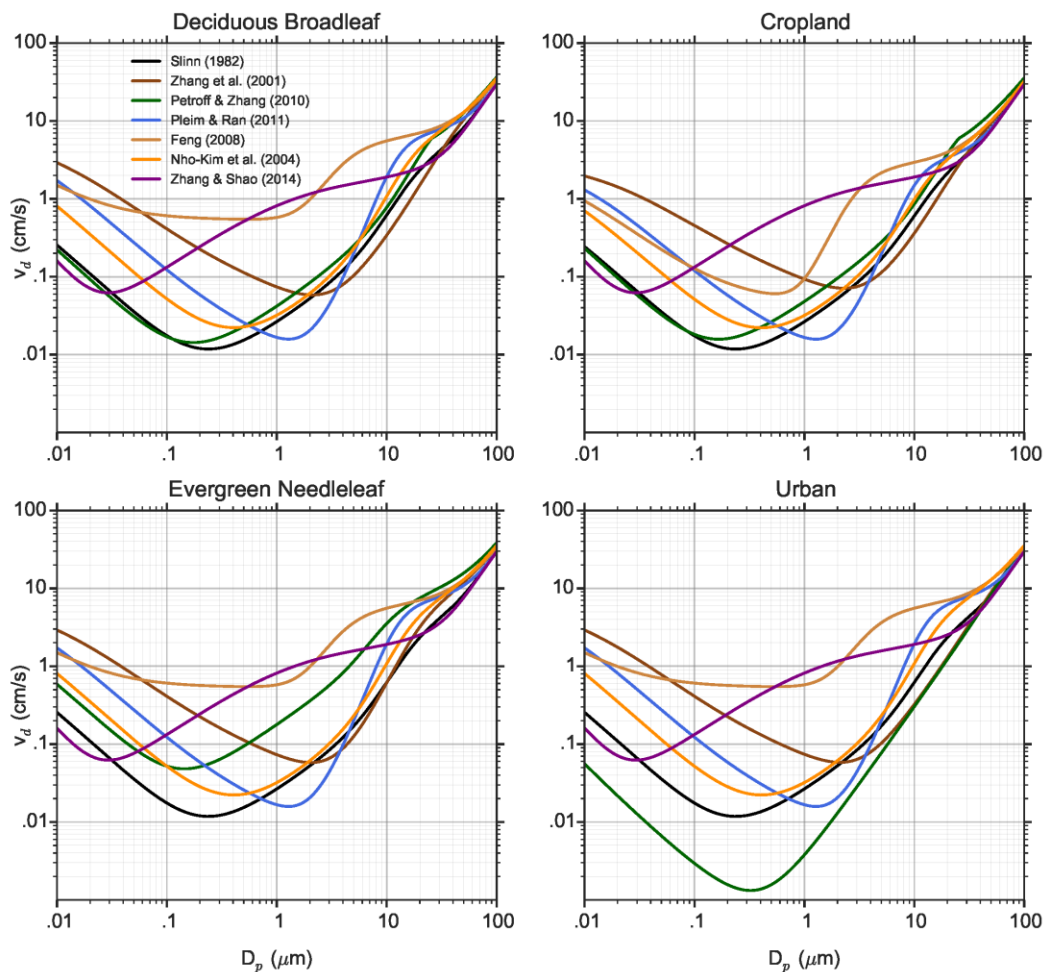

Figure 4. Aerosol deposition velocity as a function of particle size predicted by various deposition models for four surface types.

Upward fluxes of atmospheric particles above vegetative canopies were measured many years ago by Hicks et al. (1982) and Hicks et al. (1989). Recent studies, using more sensitive instrumentation over a variety of surfaces, routinely find both upward and downward particle fluxes, often with significant diurnal and day-to-day variations (Nemitz et al., 2004; Petroff, et al., 2008; Pryor, et al., 2008; Gordon et al., 2010; Vong et al., 2010; Farmer et al., 2013; Lavi et al., 2013; Pryor et al., 2013; Deventer et al., 2015; Rannik et al., 2016). Causes of upward particle fluxes above vegetative canopies may be physical, chemical or a combination, but current state-of-the-science CTMs are not designed to do anything but remove particles from the atmosphere via dry deposition at the surface (Saylor and Hicks, 2016). As described elsewhere in Section **3.2.2. Development of in-canopy source/sink models that resolve deposition to ecosystem components (crown, understory, ground) and in-canopy chemistry**, a

new approach to modeling air-surface exchanges of gases and particles in CTMs may be needed to properly simulate the complex chemical, physical and biological processes occurring near the surface.

Given the uncertainties described above for particle dry deposition processes and the importance of these processes to producing CTM-based estimates of Nr deposition, it seems clear that a dedicated effort is necessary to improve the accuracy of particle Nr deposition estimates. Although relevant particle flux data has been collected over many decades, not enough data has been collected using newer instrumentation and techniques and collected over a variety of naturally occurring surfaces in conjunction with relevant environmental and micrometeorological data to adequately resolve the issues described here. Field experiments exclusively dedicated to improving the scientific understanding of the surface-atmosphere exchange of particles are necessary to resolve known model-measurement discrepancies and determine the physical and chemical mechanisms driving the direction of above-canopy particle fluxes. Close cooperation of chemical measurement scientists, micrometeorologists and modelers in these field experiments will be vital for successful outcomes from these efforts.

Wet deposition

To estimate wet deposition, models must accurately predict the type, location, timing, duration, and intensity of precipitation as well as the size distribution of the raindrops. This information is produced by the meteorological model, but accuracy remains a challenge (Heath et al., 2016), and this topic is not the focus of the present review. Wet deposition amounts delivered to the surface include pollutant mass incorporated into cloud droplets/ice particles within the cloud-layer as well as mass collected by falling hydrometers (rain and snow). A brief summary of the approaches and uncertainty in the treatments of in- and below-cloud scavenging of gases and aerosols is provided below and some of the details can be found in earlier reviews (Zhang and Vet, 2006; Wang et al., 2010; Gong et al., 2011; Zhang et al., 2013).

Gases

In-cloud gas-scavenging results from aqueous-phase chemistry and associated processes. Uncertainties from this process are mainly from the chemical mechanism used with the CTMs which can contain different chemical species and chemical reactions. Species will vary in their solubilities which affects the extent to which they are scavenged. Another uncertainty for in-cloud scavenging is from using bulk versus size-resolved chemistry because the aqueous-phase processes depend strongly on the size distribution of hydrometers. Bulk chemistry only considers the total water content without the complication of its distribution in different cloud droplet sizes.

Below-cloud gas scavenging by rain has been treated using the scavenging coefficient approach, Henry's law equilibrium, and kinetic mass transfer (KMT) approach (Gong, et al., 2011; Fahey et al., 2017). The first approach is irreversible scavenging while the other two are reversible. The scavenging process depends on the total droplet surface area and chemical conditions (e.g., pH)

while most (chemical-species dependent) scavenging coefficient parametrizations only include precipitation rate in the formulas. The Henry's law equilibrium approach is a reasonable approximation for weakly soluble species because they can reach equilibrium with small size droplets within short time scales, but this is not the case for very soluble species and/or scavenged by large droplets. The KMT approach is theoretically correct but is computationally intensive and is seldom adopted in 3-D size-resolved aqueous-phase chemistry model simulations. Recent work by Fahey, et al. (2017) describes the implementation of KMT in CMAQ v5.1 and the resulting improvement in model performance from using it, particularly for shorter timescales. Uncertainties from this approach can arise from the representation of droplet spectra and the modelled aqueous-phase concentrations, which can be of similar order of magnitude to the other approaches.

Below-cloud gas scavenging by snow has not been considered in the majority of CTMs, but HNO_3 and NH_3 are considered in several air-quality models using the scavenging coefficient approach (Gong, et al., 2011). Significant knowledge gaps exist in this process for almost all chemical species.

Aerosols

In-cloud aerosol scavenging is from the activation process of atmospheric aerosols serving as cloud condensation or ice nuclei. Different empirical formulas have been used in CTMs for the nucleation process. One process that has been largely ignored is the coagulation scavenging of interstitial aerosols within the cloud layer, considering the minimum mass these aerosols occupy. However, while large aerosols are dominant in the overall mass, the small particles are dominant in the total number concentration, which has important implications in climate-related studies. Including coagulation scavenging is important in size-resolved aerosol CTMs.

Below-cloud particle scavenging by rain is mostly simulated using the scavenging coefficient approach (Gong, et al., 2011), although explicit coagulation theory has also been used in size-resolved cloud-aerosol models (Jacobson, 2003). Similar approaches have also been used for below-cloud particle scavenging by snow, although such a process has been ignored in some CTMs. Note that using explicit coagulation to calculate below-cloud scavenging requires explicit treatment of size-resolved droplets and aerosol particles, and uncertainties in this approach can also come from the empirical use of collection efficiency and gravitational settling velocity.

Detailed assessments of below-cloud scavenging coefficients for rain (Wang, et al., 2010) and snow (Zhang, et al., 2013) suggested uncertainties on the order of two-to three orders of magnitudes with the largest uncertainties for submicron particles. These uncertainties would cause 20-30% mass differences in CTMs predicted aerosol concentrations for fine and coarse particles on a model-domain average (Gong, et al., 2011).

Studies to date have focused on mainly larger particles, while new emphasis is being placed on ultrafine particles. Additional evaluation of scavenging coefficients for ultrafine particles is presented in Pryor et al. (2016). Lemaitre et al. (2017) suggest that additional scavenging

processes such as the capture of chemicals in the wake of a raindrop can be important for small particles and is an emerging area of interest

Future research

In this section we outline several areas of research, representing efforts that could be accomplished in the near term versus those that will require longer term study, that would improve the representation of reactive Nr fluxes in CTMs.

Near-term

NOx emissions inventories – Emissions and meteorology are fundamental inputs to CTMs and uncertainties in these inputs propagate through the modeling system. Mobile NOx emissions are thought to be biased high, particularly in the summer and in urban areas where vehicles dominate the source. These types of variabilities need to be quantified and information used to update models for mobile source emissions. Using existing data, improvement of the NOx mobile source inventory may be feasible in the nearterm.

Chemical mechanisms – The chemistry of the atmosphere is extremely complicated and while our understanding continues to grow, there are still important gaps in our knowledge. With respect to the NOy system, key uncertainties in chemical mechanisms include the fate of organic nitrates and the parameters that drive N₂O₅ hydrolysis. The fate of organic nitrates needs to be better characterized for isoprene and monoterpene dominated locations, particularly in summer. Laboratory measurements can be important for constraining the fate of organic nitrate in models by improving the understanding of the importance of the role of hydrolysis on ON versus chemical reaction or photolysis. N₂O₅ reactions are most important in winter when hydrolysis to HNO₃ controls the lifetime of NOx. Studies are needed to improve CTM parameterizations to more realistically capture the range of atmospherically relevant N₂O₅ reaction probabilities. While laboratory studies may be helpful in the near-term for both organic nitrate and N₂O₅, field sampling over the range of relevant chemical and meteorological conditions represents a long-term effort.

Gas-particle partitioning – Correctly predicting the phase of a pollutant is important in modeling the atmospheric chemistry and the deposition. Additional work is needed to characterize inputs of dust-derived nonvolatile cations to thermodynamic models, which impact the gas/aerosol partitioning of inorganic NO₃⁻ and NH₄⁺. Improving dust emissions is key to reducing uncertainties in non-volatile cations, and subsequently the phase of the chemical species modeled by CTMs, and could be improved in the near-term.

Non-stomatal exchange pathways - Development of dry deposition models cannot advance without studies that help elucidate the fundamental processes that control deposition. In particular, exchange processes that happen at the cuticle and ground surfaces (i.e., non-stomatal) need to be studied and exchange parameterizations developed that are less

empirical. Historically, gas phase fluxes to the cuticle and the ground have been parameterized from the residual resistance – i.e. the remainder after the aerodynamic, boundary layer, and stomatal resistances have been subtracted. This approach can lead to parameterizations that are only truly appropriate for the conditions being analyzed and will have great uncertainty when applied for other surface types and atmospheric conditions. Measurements to elucidate the role of surface wetness and cuticle chemistry in the canopy resistances for gas phase compounds are particularly needed. Assessment of the volume and chemistry of dew and guttation could be incorporated into flux field studies in the near-term. Additional information on this topic can be found in Section **3.1.1.2 Measurements of surface chemistry/wetness relevant to fluxes**.

Bidirectional NH₃ exchange – The bidirectional exchange of NH₃, which is a key process in accurately predicting Nr deposition budgets, is driven by the relative concentrations in the atmosphere and the surface media and is also impacted by meteorology. Better characterization of soil and vegetation emission potentials for a wide range of vegetation and soil types in North America represent a key need. Development of a database of these values for use in CTMs by conducting survey type measurements across a range of ecosystems and incorporating these measurements into process-level flux studies could be accomplished in the relatively near term. See Section **3.2.1. Application of a bidirectional ammonia air-surface exchange model at NADP AMon sites** for additional detail on research needed to improve bidirectional NH₃ flux models.

Particle dry deposition - Field experiments exclusively dedicated to improving the scientific understanding of the surface-atmosphere exchange of particles are necessary to resolve known model-measurement discrepancies and determine the physical and chemical mechanisms driving the direction of above-canopy particle fluxes. Measurements in the accumulation mode (0.1 – 2 μm diameter) are particularly needed. Given the existence of suitable technology for size resolved flux measurements and existing infrastructure such as Ameriflux for conducting measurements across a range of surface types, advances could be made in the near term.

Model intercomparison studies – In the absence of extensive measurement studies, model intercomparison studies serve to provide information on the uncertainty and variability of modeled deposition values. Additionally, model sensitivity studies can be used to inform priorities for measurements. Results from modeling studies can also be used to provide guidance on areas where there is a critical need for intensive field measurements or monitoring. Comparison of CTMs is an area of research in which advances could be made in the near-term by building on current efforts within the modeling community. For example, the next (fourth) phase of the AQMEII will evaluate model performance for nitrogen deposition. This effort provides an opportunity to assess differences between several commonly used CTMs specific to atmospheric deposition and to assess the importance and uncertainty of model processes (e.g., meteorology, surface physical characteristics, deposition parameterizations, atmospheric chemistry).

Long-term

Ammonia emission inventories - Reducing uncertainties in NH₃ emissions is a critical component of improving modeled fluxes. Ultimately, emissions from animal feeding operations need to be resolved at the facility scale (e.g., NAEMS). Development of such an emissions inventory for application within CTMs is a long-term goal that will require close collaboration with industry stakeholders, USDA and other federal agencies, as well as academic institutions. For emissions from fertilized soils, additional studies are needed to evaluate EPIC NH₃ emission potentials against soil biogeochemical N_r measurements and NH₃ fluxes. The range of soil and fertilizer types, application methods, and meteorological conditions required for significant model advancement makes this a long-term effort.

Updated measurements of air-surface exchange - Air-surface exchange processes are critical components of all atmospheric models, including those for weather, climate and air quality. The exchange of energy, moisture, momentum and trace chemical species drive much of the behavior and composition of the lower atmosphere. Historically, air-surface exchange of chemical species has been treated separate from, and not always consistent with, the physical processes of exchange. Moreover, our current conceptual understanding of air-surface exchange and the algorithms developed from that understanding date to the 1970's and 1980's, having changed (or been challenged) very little in the intervening years. Yet, despite the recognized importance of air-surface exchange to producing accurate predictions of atmospheric behavior and composition, and despite the availability of new instrumentation and technologies for the more precise measurement of fluxes for a wider suite of gases and size-resolved particles, there remains a dearth of appropriate data available to update how these processes are represented in current models. Given its importance to accurate atmospheric predictions, and to N_r deposition in particular, it seems necessary to invest in dedicated measurement campaigns, closely integrated with a variety of modeling approaches, to improve the scientific understanding of air-surface exchange. It is important that measurement campaigns characterize fluxes that are resolved temporally and spatially, and cover a wide variety of surface types and chemical regimes. There is a need to make in-canopy profile measurements to understand chemical cycling that may be occurring and impacts on net canopy-scale fluxes. It is also important to measure the full chemical budget to understand how NO_y and NH_x are cycling in the system. This includes measuring BVOCs to be able to understand chemical interactions between biogenic emissions and NO_x. Such fundamental advancements in air-surface exchange represent a long-term effort. Additional detail related to flux measurements and related research needs can be found in Section **3.1.1.1. Measurements of air-surface exchange of N_r in natural ecosystems across North America**.

Long-term measurement studies – Long-term flux measurement studies are needed that span multiple seasons and multiple years. Such studies will inform our understanding of the impact

of changing weather and climate patterns, emissions control strategies, and plant stresses on deposition processes and accurate representation of these patterns and trends in CTMs.

Amines – With respect to ON, the importance of amines as a component of the total Nr deposition budget has not been firmly established. Reducing uncertainties in the emissions, atmospheric chemistry, and air-surface exchange processes of amines represents a long-term effort.

References

- Almeida, J., Schobesberger, S., Kürten, A., Ortega, I.K., Kupiainen-Määttä, O., Praplan, A.P., Adamov, A., Amorim, A., Bianchi, F., Breitenlechner, M., David, A., Dommen, J., Donahue, N.M., Downard, A., Dunne, E., Duplissy, J., Ehrhart, S., Flagan, R.C., Franchin, A., Guida, R., Hakala, J., Hansel, A., Heinritzi, M., Henschel, H., Jokinen, T., Junninen, H., Kajos, M., Kangasluoma, J., Keskinen, H., Kupc, A., Kurtén, T., Kvashin, A.N., Laaksonen, A., Lehtipalo, K., Leiminger, M., Leppä, J., Loukonen, V., Makhmutov, V., Mathot, S., McGrath, M.J., Nieminen, T., Olenius, T., Onnela, A., Petäjä, T., Riccobono, F., Riipinen, I., Rissanen, M., Rondo, L., Ruuskanen, T., Santos, F.D., Sarnela, N., Schallhart, S., Schnitzhofer, R., Seinfeld, J.H., Simon, M., Sipilä, M., Stozhkov, Y., Stratmann, F., Tomé, A., Tröstl, J., Tsagkogeorgas, G., Vaattovaara, P., Viisanen, Y., Virtanen, A., Vrtala, A., Wagner, P.E., Weingartner, E., Wex, H., Williamson, C., Wimmer, D., Ye, P., Yli-Juuti, T., Carslaw, K.S., Kulmala, M., Curtius, J., Baltensperger, U., Worsnop, D.R., Vehkamäki, H., Kirkby, J., 2013. Molecular understanding of sulphuric acid–amine particle nucleation in the atmosphere. *Nature* 502, 359.
- Anderson, D.C., Loughner, C.P., Diskin, G., Weinheimer, A., Canty, T.P., Salawitch, R.J., Worden, H.M., Fried, A., Mikoviny, T., Wisthaler, A., Dickerson, R.R., 2014. Measured and modeled CO and NO_y in DISCOVER-AQ: An evaluation of emissions and chemistry over the eastern US. *Atmospheric Environment* 96, 78-87.
- Appel, K.W., Pouliot, G.A., Simon, H., Sarwar, G., Pye, H.O.T., Napelenok, S.L., Akhtar, F., Roselle, S.J., 2013. Evaluation of dust and trace metal estimates from the Community Multiscale Air Quality (CMAQ) model version 5.0. *Geosci. Model Dev.* 6, 883-899.
- Bash, J.O., Cooter, E.J., Dennis, R.L., Walker, J.T., Pleim, J.E., 2013. Evaluation of a regional air-quality model with bidirectional NH₃ exchange coupled to an agroecosystem model. *Biogeosciences* 10, 1635-1645.
- Browne, E.C., Cohen, R.C., 2012. Effects of biogenic nitrate chemistry on the NO_x lifetime in remote continental regions. *Atmos. Chem. Phys.* 12, 11917-11932.
- Burkhardt, J., Hunsche, M., 2013. “Breath figures” on leaf surfaces—formation and effects of microscopic leaf wetness. *Frontiers in Plant Science* 4.

- Carter, W.P.L., 2010. Development of the SAPRC-07 chemical mechanism. *Atmospheric Environment* 44, 5324-5335.
- Cooter, E.J., Bash, J.O., Benson, V., Ran, L., 2012. Linking agricultural crop management and air quality models for regional to national-scale nitrogen assessments. *Biogeosciences* 9, 4023-4035.
- Deventer, M.J., El-Madany, T., Griessbaum, F., Klemm, O., 2015. One-year measurement of size-resolved particle fluxes in an urban area. *Tellus B: Chemical and Physical Meteorology* 67, 25531.
- Ellis, R.A., Jacob, D.J., Sulprizio, M.P., Zhang, L., Holmes, C.D., Schichtel, B.A., Blett, T., Porter, E., Pardo, L.H., Lynch, J.A., 2013. Present and future nitrogen deposition to national parks in the United States: critical load exceedances. *Atmos. Chem. Phys.* 13, 9083-9095.
- Emery, C., Jung, J., Koo, B., Yarwood, G., 2015. Improvements to CAMx Snow Cover Treatments and Carbon Bond Chemical Mechanism for Winter Ozone. Ramboll Environ. Novato, CA.
- Fahey, K.M., Carlton, A.G., Pye, H.O.T., Baek, J., Hutzell, W.T., Stanier, C.O., Baker, K.R., Appel, K.W., Jaoui, M., Offenberg, J.H., 2017. A framework for expanding aqueous chemistry in the Community Multiscale Air Quality (CMAQ) model version 5.1. *Geosci. Model Dev.* 10, 1587-1605.
- Farmer, D.K., Chen, Q., Kimmel, J.R., Docherty, K.S., Nemitz, E., Artaxo, P.A., Cappa, C.D., Martin, S.T., Jimenez, J.L., 2013. Chemically Resolved Particle Fluxes Over Tropical and Temperate Forests. *Aerosol Science and Technology* 47, 818-830.
- Fisher, J.A., Jacob, D.J., Travis, K.R., Kim, P.S., Marais, E.A., Chan Miller, C., Yu, K., Zhu, L., Yantosca, R.M., Sulprizio, M.P., Mao, J., Wennberg, P.O., Crouse, J.D., Teng, A.P., Nguyen, T.B., St. Clair, J.M., Cohen, R.C., Romer, P., Nault, B.A., Wooldridge, P.J., Jimenez, J.L., Campuzano-Jost, P., Day, D.A., Hu, W., Shepson, P.B., Xiong, F., Blake, D.R., Goldstein, A.H., Misztal, P.K., Hanisco, T.F., Wolfe, G.M., Ryerson, T.B., Wisthaler, A., Mikoviny, T., 2016. Organic nitrate chemistry and its implications for nitrogen budgets in an isoprene- and monoterpene-rich atmosphere: constraints from aircraft (SEAC4RS) and ground-based (SOAS) observations in the Southeast US. *Atmos. Chem. Phys.* 16, 5969-5991.
- Fountoukis, C., Nenes, A., 2007. ISORROPIA II: a computationally efficient thermodynamic equilibrium model for K^+ - Ca^{2+} - Mg^{2+} - NH_4^+ - Na^+ - SO_4^{2-} - NO_3^- - Cl^- - H_2O aerosols. *Atmos. Chem. Phys.* 7, 4639-4659.
- Ge, X., Wexler, A.S., Clegg, S.L., 2011. Atmospheric amines – Part I. A review. *Atmospheric Environment* 45, 524-546.
- Gong, W., Stroud, C., Zhang, L., 2011. Cloud Processing of Gases and Aerosols in Air Quality Modeling. *Atmosphere* 2, 567-616.

- Gordon, M., Staebler, R., Liggio, J., Vlasenko, A., S.-M, L., K, H., 2010. Aerosol flux measurements above a mixed forest at Borden, Ontario.
- Guo, H., Liu, J., Froyd, K.D., Roberts, J.M., Veres, P.R., Hayes, P.L., Jimenez, J.L., Nenes, A., Weber, R.J., 2017. Fine particle pH and gas–particle phase partitioning of inorganic species in Pasadena, California, during the 2010 CalNex campaign. *Atmos. Chem. Phys.* 17, 5703-5719.
- Heath, N., K., Pleim, J., E., Gilliam, R., C., Kang, D., 2016. A simple lightning assimilation technique for improving retrospective WRF simulations. *Journal of Advances in Modeling Earth Systems* 8, 1806-1824.
- Hicks, B.B., 1986. Measuring dry deposition: A re-assessment of the state of the art. *Water, Air, and Soil Pollution* 30, 75-90.
- Hicks, B.B., 1995. On the determination of total deposition to remote areas, in: Heij, G.J., Erisman, J.W. (Eds.), *Studies in Environmental Science*. Elsevier, pp. 163-173.
- Hicks, B.B., Matt, D.R., McMillen, R.T., Womack, J.D., Wesely, M.L., Hart, R.L., Cook, D.R., Lindberg, S.E., Pena, R.G., Thomson, D.W., 1989. A field investigation of sulfate fluxes to a deciduous forest. *Journal of Geophysical Research: Atmospheres* 94, 13003-13011.
- Hicks, B.B., Saylor, R.D., Baker, B.D., 2016. Dry deposition of particles to canopies—A look back and the road forward. *Journal of Geophysical Research: Atmospheres* 121, 14,691-14,707.
- Hicks, B.B., Wesely, M.L., Durham, J.L., Brown, M.A., 1982. Some direct measurements of atmospheric sulfur fluxes over a pine plantation. *Atmospheric Environment (1967)* 16, 2899-2903.
- Im, U., Bianconi, R., Solazzo, E., Kioutsioukis, I., Badia, A., Balzarini, A., Baró, R., Bellasio, R., Brunner, D., Chemel, C., et al., 2015. Evaluation of operational online-coupled regional air quality models over Europe and North America in the context of AQMEII phase 2. Part II: Particulate Matter. *Atmospheric Environment* 115, 421-441.
- Jacobson, M.Z., 2003. Development of mixed-phase clouds from multiple aerosol size distributions and the effect of the clouds on aerosol removal. *Journal of Geophysical Research: Atmospheres* 108.
- Jenkin, M.E., Saunders, S.M., Pilling, M.J., 1997. The tropospheric degradation of volatile organic compounds: a protocol for mechanism development. *Atmospheric Environment* 31, 81-104.
- Kenagy, H.S., Sparks, T.L., Ebben, C.J., Wooldridge, P.J., Lopez-Hilfiker, F.D., Lee, B.H., Thornton, J.A., McDuffie, E.E., Fibiger, D.L., Brown, S.S., Montzka, D.D., Weinheimer, A.J., Schroder, J.C., Campuzano-Jost, P., Day, D.A., Jimenez, J.L., Dibb, J.E., Campos, T., Shah, V., Jaeglé, L., Cohen, R.C., 2018. NO_x Lifetime and NO_y Partitioning During WINTER. *Journal of Geophysical Research: Atmospheres* 123, 9813-9827.

Khan, T.R., Perlinger, J.A., 2017. Evaluation of five dry particle deposition parameterizations for incorporation into atmospheric transport models. *Geosci. Model Dev.* 10, 3861-3888.

Kuhn, U., Sintermann, J., Spirig, C., Jocher, M., Ammann, C., Neftel, A., 2011. Basic biogenic aerosol precursors: Agricultural source attribution of volatile amines revised. *Geophysical Research Letters* 38.

Lamaud, E., Loubet, B., Irvine, M., Stella, P., Personne, E., Cellier, P., 2009. Partitioning of ozone deposition over a developed maize crop between stomatal and non-stomatal uptakes, using eddy-covariance flux measurements and modelling. *Agricultural and Forest Meteorology* 149, 1385-1396.

Lavi, A., Farmer, D.K., Segre, E., Moise, T., Rotenberg, E., Jimenez, J.L., Rudich, Y., 2013. Fluxes of Fine Particles Over a Semi-Arid Pine Forest: Possible Effects of a Complex Terrain. *Aerosol Science and Technology* 47, 906-915.

Lee, B.H., Mohr, C., Lopez-Hilfiker, F.D., Lutz, A., Hallquist, M., Lee, L., Romer, P., Cohen, R.C., Iyer, S., Kurtén, T., Hu, W., Day, D.A., Campuzano-Jost, P., Jimenez, J.L., Xu, L., Ng, N.L., Guo, H., Weber, R.J., Wild, R.J., Brown, S.S., Koss, A., de Gouw, J., Olson, K., Goldstein, A.H., Seco, R., Kim, S., McAvey, K., Shepson, P.B., Starn, T., Baumann, K., Edgerton, E.S., Liu, J., Shilling, J.E., Miller, D.O., Brune, W., Schobesberger, S., D'Ambro, E.L., Thornton, J.A., 2016. Highly functionalized organic nitrates in the southeast United States: Contribution to secondary organic aerosol and reactive nitrogen budgets. *Proceedings of the National Academy of Sciences* 113, 1516-1521.

Lemaitre, P., Querel, A., Monier, M., Menard, T., Porcheron, E., Flossmann, A.I., 2017. Experimental evidence of the rear capture of aerosol particles by raindrops. *Atmos. Chem. Phys.* 17, 4159-4176.

Li, Y., Schichtel, B.A., Walker, J.T., Schwede, D.B., Chen, X., Lehmann, C.M.B., Puchalski, M.A., Gay, D.A., Collett, J.L., 2016. Increasing importance of deposition of reduced nitrogen in the United States. *Proceedings of the National Academy of Sciences* 113, 5874-5879.

Lonsdale, C.R., Hegarty, J.D., Cady-Pereira, K.E., Alvarado, M.J., Henze, D.K., Turner, M.D., Capps, S.L., Nowak, J.B., Neuman, J.A., Middlebrook, A.M., Bahreini, R., Murphy, J.G., Markovic, M.Z., VandenBoer, T.C., Russell, L.M., Scarino, A.J., 2017. Modeling the diurnal variability of agricultural ammonia in Bakersfield, California, during the CalNex campaign. *Atmos. Chem. Phys.* 17, 2721-2739.

Luecken, D.J., Tonnesen, G.S., Sickles, I.J.E., 1999. Differences in NO_y speciation predicted by three photochemical mechanisms. *Atmospheric Environment* 33, 1073-1084.

Massad, R.S., Nemitz, E., Sutton, M.A., 2010. Review and parameterisation of bi-directional ammonia exchange between vegetation and the atmosphere. *Atmos. Chem. Phys.* 10, 10359-10386.

- McDonald, B.C., Dallmann, T.R., Martin, E.W., Harley, R.A., 2012. Long-term trends in nitrogen oxide emissions from motor vehicles at national, state, and air basin scales. *Journal of Geophysical Research: Atmospheres* 117.
- McDonald, B.C., McKeen, S.A., Cui, Y.Y., Ahmadov, R., Kim, S.-W., Frost, G.J., Pollack, I.B., Peischl, J., Ryerson, T.B., Holloway, J.S., Graus, M., Warneke, C., Gilman, J.B., de Gouw, J.A., Kaiser, J., Keutsch, F.N., Hanisco, T.F., Wolfe, G.M., Trainer, M., 2018. Modeling Ozone in the Eastern U.S. using a Fuel-Based Mobile Source Emissions Inventory. *Environmental Science & Technology* 52, 7360-7370.
- McDuffie, E.E., Fibiger, D.L., Dubé, W.P., Lopez-Hilfiker, F., Lee, B.H., Thornton, J.A., Shah, V., Jaeglé, L., Guo, H., Weber, R.J., Michael Reeves, J., Weinheimer, A.J., Schroder, J.C., Campuzano-Jost, P., Jimenez, J.L., Dibb, J.E., Veres, P., Ebben, C., Sparks, T.L., Wooldridge, P.J., Cohen, R.C., Hornbrook, R.S., Apel, E.C., Campos, T., Hall, S.R., Ullmann, K., Brown, S.S., 2018. Heterogeneous N₂O₅ Uptake During Winter: Aircraft Measurements During the 2015 WINTER Campaign and Critical Evaluation of Current Parameterizations. *Journal of Geophysical Research: Atmospheres* 123, 4345-4372.
- Murphy, S.M., Sorooshian, A., Kroll, J.H., Ng, N.L., Chhabra, P., Tong, C., Surratt, J.D., Knipping, E., Flagan, R.C., Seinfeld, J.H., 2007. Secondary aerosol formation from atmospheric reactions of aliphatic amines. *Atmos. Chem. Phys.* 7, 2313-2337.
- Nemitz, E., Milford, C., Sutton, M.A., 2001. A two-layer canopy compensation point model for describing bi-directional biosphere-atmosphere exchange of ammonia. *Quarterly Journal of the Royal Meteorological Society* 127, 815-833.
- Nemitz, E., Sutton, M.A., Wyers, G.P., Otjes, R.P., Mennen, M.G., van Putten, E.M., Gallagher, M.W., 2004. Gas-particle interactions above a Dutch heathland: II. Concentrations and surface exchange fluxes of atmospheric particles. *Atmos. Chem. Phys.* 4, 1007-1024.
- Ng, N.L., Brown, S.S., Archibald, A.T., Atlas, E., Cohen, R.C., Crowley, J.N., Day, D.A., Donahue, N.M., Fry, J.L., Fuchs, H., Griffin, R.J., Guzman, M.I., Herrmann, H., Hodzic, A., Iinuma, Y., Jimenez, J.L., Kiendler-Scharr, A., Lee, B.H., Luecken, D.J., Mao, J., McLaren, R., Mutzel, A., Osthoff, H.D., Ouyang, B., Picquet-Varrault, B., Platt, U., Pye, H.O.T., Rudich, Y., Schwantes, R.H., Shiraiwa, M., Stutz, J., Thornton, J.A., Tilgner, A., Williams, B.J., Zaveri, R.A., 2017. Nitrate radicals and biogenic volatile organic compounds: oxidation, mechanisms, and organic aerosol. *Atmos. Chem. Phys.* 17, 2103-2162.
- Petroff, A., Mailliat, A., Amielh, M., Anselmet, F., 2008. Aerosol dry deposition on vegetative canopies. Part I: Review of present knowledge. *Atmospheric Environment* 42, 3625-3653.
- Pleim, J.E., Bash, J.O., Walker, J.T., Cooter, E.J., 2013. Development and evaluation of an ammonia bidirectional flux parameterization for air quality models. *Journal of Geophysical Research: Atmospheres* 118, 3794-3806.

- Price, D.J., Clark, C.H., Tang, X., Cocker, D.R., Purvis-Roberts, K.L., Silva, P.J., 2014. Proposed chemical mechanisms leading to secondary organic aerosol in the reactions of aliphatic amines with hydroxyl and nitrate radicals. *Atmospheric Environment* 96, 135-144.
- Pryor, S., M. Joerger, V., Sullivan, R., 2016. Empirical estimates of size-resolved precipitation scavenging coefficients for ultrafine particles.
- Pryor, S.C., Barthelmie, R.J., Hornsby, K.E., 2013. Size-Resolved Particle Fluxes and Vertical Gradients over and in a Sparse Pine Forest. *Aerosol Science and Technology* 47, 1248-1257.
- Pryor, S.C., Gallagher, M., Sievering, H., Larsen, S.E., Barthelmie, R.J., Birsan, F., Nemitz, E., Rinne, J., Kulmala, M., Groenholm, T., Taipale, R., Vesala, T., 2008. A review of measurement and modelling results of particle atmosphere-surface exchange. *Tellus Series B-Chemical and Physical Meteorology* 60, 42-75.
- Pye, H.O., Luecken, D.J., Xu, L., Boyd, C.M., Ng, N.L., Baker, K.R., Ayres, B.R., Bash, J.O., Baumann, K., Carter, W.P., Edgerton, E., Fry, J.L., Hutzell, W.T., Schwede, D.B., Shepson, P.B., 2015. Modeling the current and future roles of particulate organic nitrates in the southeastern United States. *Environmental Science & Technology* 49, 14195-14203.
- Pye, H.O.T., Zuend, A., Fry, J.L., Isaacman-VanWertz, G., Capps, S.L., Appel, K.W., Foroutan, H., Xu, L., Ng, N.L., Goldstein, A.H., 2018. Coupling of organic and inorganic aerosol systems and the effect on gas-particle partitioning in the southeastern US. *Atmos. Chem. Phys.* 18, 357-370.
- Rannik, Ü., Zhou, L., Zhou, P., Gierens, R., Mammarella, I., Sogachev, A., Boy, M., 2016. Aerosol dynamics within and above forest in relation to turbulent transport and dry deposition. *Atmos. Chem. Phys.* 16, 3145-3160.
- Sarwar, G., Godowitch, J., Henderson, B.H., Fahey, K., Pouliot, G., Hutzell, W.T., Mathur, R., Kang, D., Goliff, W.S., Stockwell, W.R., 2013. A comparison of atmospheric composition using the Carbon Bond and Regional Atmospheric Chemistry Mechanisms. *Atmos. Chem. Phys.* 13, 9695-9712.
- Saylor, R.D., Hicks, B.B., 2016. New directions: Time for a new approach to modeling surface-atmosphere exchanges in air quality models? *Atmospheric Environment* 129, 229-233.
- Schwede, D.B., Lear, G.G., 2014. A novel hybrid approach for estimating total deposition in the United States. *Atmospheric Environment* 92, 207-220.
- Seinfeld, J.H., Pandis, S.N., 1998. *Atmospheric chemistry and physics: from air pollution to climate change*. Wiley.
- Simpson, D., Benedictow, A., Berge, H., Bergström, R., Emberson, L.D., Fagerli, H., Flechard, C.R., Hayman, G.D., Gauss, M., Jonson, J.E., Jenkin, M.E., Nyíri, A., Richter, C., Semeena, V.S., Tsyro, S., Tuovinen, J.P., Valdebenito, Á., Wind, P., 2012. The EMEP MSC-W chemical transport model – technical description. *Atmos. Chem. Phys.* 12, 7825-7865.

Sintermann, J., Schallhart, S., Kajos, M., Jocher, M., Bracher, A., Munger, A., Johnson, D., Neftel, A., Ruuskanen, T., 2014. Trimethylamine emissions in animal husbandry. *Biogeosciences* 11, 5073-5085.

Slinn, W.G.N., 1982. Predictions for particle deposition to vegetative canopies. *Atmospheric Environment* (1967) 16, 1785-1794.

Solazzo, E., Bianconi, R., Pirovano, G., Matthias, V., Vautard, R., Moran, M.D., Appel, K.W., Bessagnet, B., Brandt, J., Christensen, J.H., Chemel, C., Coll, I., Ferreira, J., Forkel, R., Francis, X.V., Grell, G., Grossi, P., Hansen, A.B., Miranda, A.I., Nopmongkol, U., Prank, M., Sartelet, K.N., Schaap, M., Silver, J.D., Sokhi, R.S., Vira, J., Werhahn, J., Wolke, R., Yarwood, G., Zhang, J., Rao, S.T., Galmarini, S., 2012. Operational model evaluation for particulate matter in Europe and North America in the context of AQMEII. *Atmospheric Environment* 53, 75-92.

Sutton, M.A., Nemitz, E., Milford, C., Campbell, C., Erisman, J.W., Hensen, A., Cellier, P., David, M., Loubet, B., Personne, E., Schjoerring, J.K., Mattsson, M., Dorsey, J.R., Gallagher, M.W., Horvath, L., Weidinger, T., Meszaros, R., Dammgen, U., Neftel, A., Herrmann, B., Lehman, B.E., Flechard, C., Burkhardt, J., 2009. Dynamics of ammonia exchange with cut grassland: synthesis of results and conclusions of the GRAMINAE Integrated Experiment. *Biogeosciences* 6, 2907-2934.

Tan, J., Fu, J.S., Dentener, F., Sun, J., Emmons, L., Tilmes, S., Sudo, K., Flemming, J., Jonson, J.E., Gravel, S., Bian, H., Davila, Y., Henze, D.K., Lund, M.T., Kucsera, T., Takemura, T., Keating, T., 2018. Multi-model study of HTAP II on sulfur and nitrogen deposition. *Atmos. Chem. Phys.* 18, 6847-6866.

Travis, K.R., Jacob, D.J., Fisher, J.A., Kim, P.S., Marais, E.A., Zhu, L., Yu, K., Miller, C.C., Yantosca, R.M., Sulprizio, M.P., Thompson, A.M., Wennberg, P.O., Crouse, J.D., St. Clair, J.M., Cohen, R.C., Laughner, J.L., Dibb, J.E., Hall, S.R., Ullmann, K., Wolfe, G.M., Pollack, I.B., Peischl, J., Neuman, J.A., Zhou, X., 2016. Why do models overestimate surface ozone in the Southeast United States? *Atmos. Chem. Phys.* 16, 13561-13577.

Vasilakos, P., Russell, A., Weber, R., Nenes, A., 2018. Understanding nitrate formation in a world with less sulfate. *Atmos. Chem. Phys. Discuss.* 2018, 1-27.

Vivanco, M.G., Theobald, M.R., Garca-Gomez, H., Garrido, J.L., Prank, M., Aas, W., Adani, M., Alyuz, U., Andersson, C., Bellasio, R., Bessagnet, B., Bianconi, R., Bieser, J., Brandt, J., Briganti, G., Cappelletti, A., Curci, G., Christensen, J.H., Colette, A., Couvidat, F., Cuvelier, C., D'Isidoro, M., Flemming, J., Fraser, A., Geels, C., Hansen, K.M., Hogrefe, C., Im, U., Jorba, O., Kitwiroon, N., Manders, A., Mircea, M., Otero, N., Pay, M.T., Pozzoli, L., Solazzo, E., Tsyro, S., Unal, A., Wind, P., Galmarini, S., 2018. Modeled deposition of nitrogen and sulfur in Europe estimated by 14 air quality model systems: evaluation, effects of changes in emissions and implications for habitat protection. *Atmos. Chem. Phys.* 18, 10199-10218.

- Vong, R.J., Vong, I.J., Vickers, D., Covert, D.S., 2010. Size-dependent aerosol deposition velocities during BEARPEX'07. *Atmos. Chem. Phys.* 10, 5749-5758.
- Wang, X., Zhang, L., Moran, M.D., 2010. Uncertainty assessment of current size-resolved parameterizations for below-cloud particle scavenging by rain. *Atmos. Chem. Phys.* 10, 5685-5705.
- Weber, R.J., Guo, H., Russell, A.G., Nenes, A., 2016. High aerosol acidity despite declining atmospheric sulfate concentrations over the past 15 years. *Nature Geoscience* 9, 282.
- Wesely, M.L., 1989. Parameterization of surface resistances to gaseous dry deposition in regional-scale numerical models. *Atmospheric Environment (1967)* 23, 1293-1304.
- Wichink Kruit, R.J., Schaap, M., Sauter, F.J., van Zanten, M.C., van Pul, W.A.J., 2012. Modeling the distribution of ammonia across Europe including bi-directional surface-atmosphere exchange. *Biogeosciences* 9, 5261-5277.
- Wu, Z., Schwede, D.B., Vet, R., Walker, J.T., Shaw, M., Staebler, R., Zhang, L., 2018. Evaluation and Intercomparison of Five North American Dry Deposition Algorithms at a Mixed Forest Site. *Journal of Advances in Modeling Earth Systems* 10, 1571-1586.
- Xie, Y., Paulot, F., Carter, W.P.L., Nolte, C.G., Luecken, D.J., Hutzell, W.T., Wennberg, P.O., Cohen, R.C., Pinder, R.W., 2013. Understanding the impact of recent advances in isoprene photooxidation on simulations of regional air quality. *Atmos. Chem. Phys.* 13, 8439-8455.
- Xu, L., Guo, H., Boyd, C.M., Klein, M., Bougiatioti, A., Cerully, K.M., Hite, J.R., Isaacman-VanWertz, G., Kreisberg, N.M., Knote, C., Olson, K., Koss, A., Goldstein, A.H., Hering, S.V., de Gouw, J., Baumann, K., Lee, S.-H., Nenes, A., Weber, R.J., Ng, N.L., 2015. Effects of anthropogenic emissions on aerosol formation from isoprene and monoterpenes in the southeastern United States. *Proceedings of the National Academy of Sciences* 112, 37-42.
- Yu, H., McGraw, R., Lee, S.-H., 2012. Effects of amines on formation of sub-3 nm particles and their subsequent growth. *Geophysical Research Letters* 39.
- Zhang, L., Brook, J.R., Vet, R., 2003. A revised parameterization for gaseous dry deposition in air-quality models. *Atmos. Chem. Phys.* 3, 2067-2082.
- Zhang, L., Vet, R., 2006. A review of current knowledge concerning size-dependent aerosol removal. *China Particuology* 4, 272-282.
- Zhang, L., Wang, X., Moran, M.D., Feng, J., 2013. Review and uncertainty assessment of size-resolved scavenging coefficient formulations for below-cloud snow scavenging of atmospheric aerosols. *Atmos. Chem. Phys.* 13, 10005-10025.

Zhang, L., Wright, L.P., Asman, W.A.H., 2010. Bi-directional air-surface exchange of atmospheric ammonia: A review of measurements and a development of a big-leaf model for applications in regional-scale air-quality models. *J. Geophys. Res.* 115, D20310.

Zhu, L., Henze, D., Bash, J., Jeong, G.R., Cady-Pereira, K., Shephard, M., Luo, M., Paulot, F., Capps, S., 2015. Global evaluation of ammonia bidirectional exchange and livestock diurnal variation schemes. *Atmos. Chem. Phys.* 15, 12823-12843.

3.2.4. Assessing uncertainty in total Nr deposition estimates for North American critical load applications

John Walker¹, Michael D. Bell², Donna Schwede¹, Amanda Cole³, Gregory M. Beachley⁴, Gary Lear⁴, Zhiyong Wu¹

¹U.S. EPA, Office of Research and Development, Durham, NC

²National Park Service, Air Resources Division, Lakewood, CO

³Environment and Climate Change Canada, Air Quality Research Division, Toronto, ON

⁴U.S. EPA, Office of Air Programs, Washington, DC

Research topic summary

Critical loads are used to quantify the amount of atmospheric deposition (load) that can be tolerated by ecosystems without significant harm or change occurring. Determination of the amount of deposition to the ecosystem in excess of the critical load (i.e. “exceedance”) requires an estimate of total deposition, which is typically derived from gridded chemical transport models (CTMs) or a combination of measurements and CTM output. Because the critical load exceedance is a metric used to inform policy decisions, uncertainty estimates for both the critical load and the exceedance itself are useful. Estimates of uncertainty in the total deposition estimates most commonly used for North American ecosystem assessments are not currently available to the critical loads community.

Research is needed in several areas to further assess uncertainty in measured and modeled Nr deposition budgets and to address the most important contributing knowledge and data gaps. Progress could be made on several topics in the near-term by building on current work. Efforts are underway to develop databases of non-network deposition measurements, including throughfall and direct dry deposition measurements that can be used for more detailed model evaluations and process level improvements to model algorithms. Since various CTMs are used to model deposition, comparisons and evaluations of commonly used models are needed to better understand model to model differences in deposition. This has been planned through phase four of the AQMEII study (2019) will focus on evaluating model performance for atmospheric deposition and will provide output parameters related to wet and dry deposition that were not necessarily retained in previous studies, allowing for a more detailed process-level comparison of deposition than possible in previous AQMEII efforts. Comparison of TDep and ADAGIO measurement-model fusion (MMF) approaches, which are used for North American deposition mapping, is also needed. Adoption of methods within CTMs to output land

use specific deposition velocities and fluxes for ecological applications would represent an improvement over grid-averaged output that could be implemented in the near term. Geographical expansion of lichen sampling to improve biomonitoring deposition models could also be accomplished in the near term.

Other research needs represent long-term efforts. For example, exploration of the use of satellite data in measurement-model fusion approaches is needed. This could include the use of satellite data to evaluate model concentration fields, refine the spatial weighting of measurement versus modeled concentrations in MMF procedures, and inform the expansion of ground-based monitoring to fill geographical gaps for species such as NH_3 and NO_2 . Establishment of long-term sites for reactive chemical flux measurements across different ecosystems and deposition regimes is needed for improving dry deposition models and calibrating throughfall measurements. Incorporation of routine measurements of bulk organic Nr into NADP, CASTNET and CAPMoN sampling and analytical protocols is needed to improve the completeness of nitrogen speciation for deposition budgets. Improvement of dry deposition algorithms in CTMs is an ongoing long-term endeavor, with a focus on parameterizations of non-stomatal exchange pathways. Consideration of the influence of in- and near-canopy chemistry on net exchange fluxes is also needed, particularly for forests. Along with incorporation of organic Nr measurements in national monitoring networks, a more detailed treatment of organic Nr, particularly reduced forms, in CTMs is also a long-term goal. Development of methods for mapping land use specific deposition velocities and fluxes and bias correction of bidirectionally exchanged compounds in MMF procedures are also needed. An ultimate goal would be to generate maps of uncertainty that could accompany maps of total deposition for critical loads assessments.

Introduction

Nr additions can lead to detrimental effects in terrestrial and aquatic ecosystems. The *“quantitative estimate of an exposure ... below which significant harmful effects on specified sensitive elements of the environment do not occur according to present knowledge”* is known as the critical load (Nilsson and Grennfelt, 1988). These values are to inform policy and management decisions pertaining to sources of Nr. To measure and calculate a critical load, and determine the risk of ecosystem effects in similar habitats, it is necessary to have an accurate quantification of the amount of Nr being added to the ecosystem. The deposition values used to determine these estimates come from direct measurements of deposition, modeled values, and manipulation of background deposition through fertilization. But, the uncertainty between Nr deposition estimates and ecosystem responses needs to be understood across measurement and model types to evaluate the risk to the ecosystem.

Critical loads have been developed for a number of ecosystem impacts including terrestrial and aquatic acidification, forest-tree health, NO_3^- leaching, changes in plant community composition, and changes in lichen communities (Clark et al., 2018). Exceedance of the critical

load occurs when the amount of Nr deposited to an area is greater than the threshold designated for change to occur. Exceedances can negatively affect aspects of ecosystem structure and function that produce the ecosystem services that benefit people (Munns et al., 2015), including clean air and water, recreational opportunities, visibility, food and materials, and cultural and spiritual values (Bell et al., 2017). The deposition estimate used to evaluate a critical load can influence whether an exceedance is expected and can change management and policy response. Thus, it is imperative to understand how estimates used to calculate a critical load relate to other deposition estimates across scale.

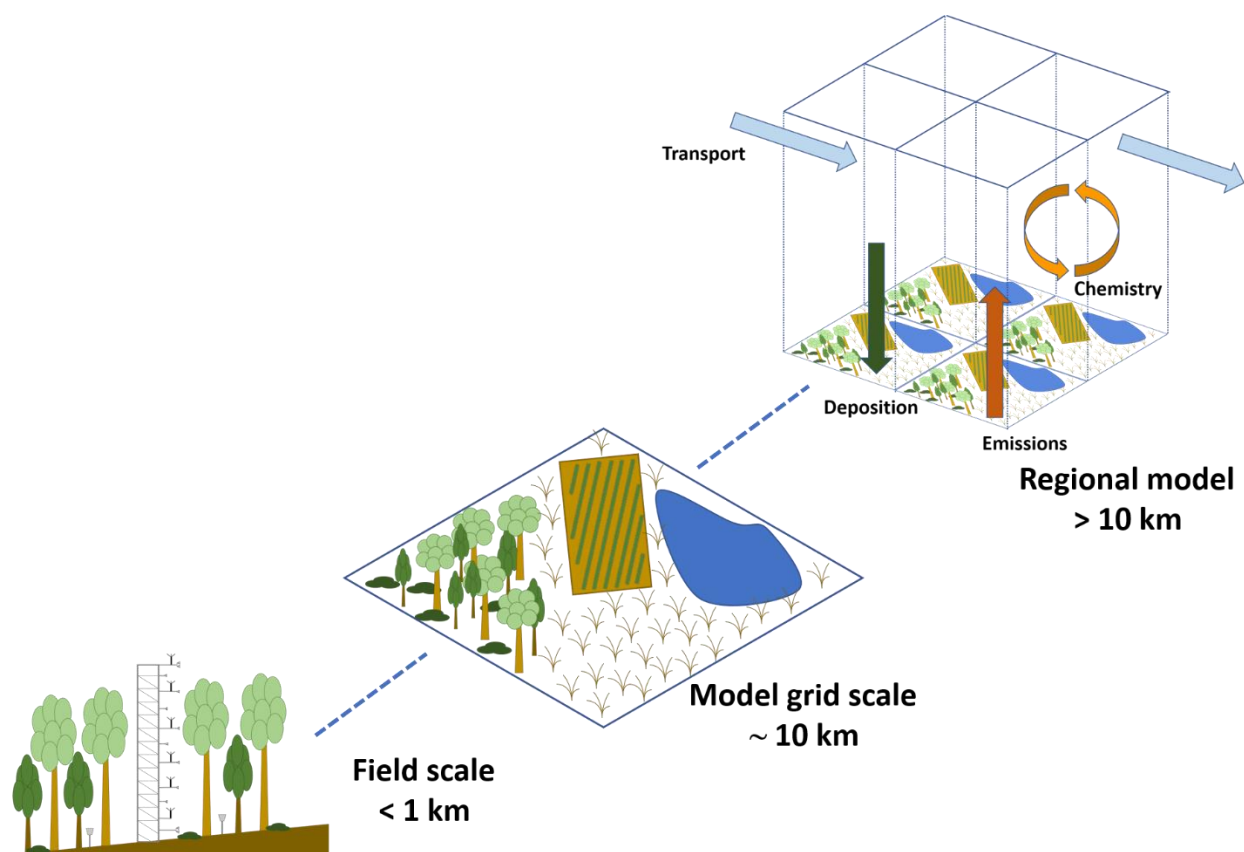

Figure 1. Spatial scales of deposition budgets used in critical loads assessments.

Figure 1 illustrates the range of spatial scales on which deposition budgets are developed for critical loads assessments. The methods used to develop budgets for each spatial scale have uncertainties associated with them. The relationships between those spatial-scale budgets will lead to propagations of their associated uncertainties. At the field scale (Figure 1), site specific deposition budgets are developed from measured wet and dry deposition rates or from inferential models. While wet deposition measurements are routine and contain relatively low uncertainty, dry deposition can only be estimated by more complex direct measurements of air-surface exchange or estimated by comparing throughfall measurements to bulk samples. Field-scale deposition budgets can be used directly in deposition assessments or used to

develop and evaluate deposition models. Most importantly, field-scale measurements are used to develop the process-level algorithms that are incorporated into inferential models, which are used to estimate site-specific deposition (e.g., CASTNET), and regional to global-scale CTMs. The accuracy and uncertainty of site-specific deposition budgets is a function of the analytical uncertainty of the measurements, the spatial and temporal representativeness of the measurements, and the completeness of the deposition budget, i.e., the extent to which all forms of Nr are represented. These uncertainties propagate in the process-level algorithms used in deposition models and in scaling up deposition budgets from the field to the ecosystem.

Since measurements of total Nr deposition are expensive and complex (e.g., dry deposition), not widespread, and often cannot be adequately spatially interpolated, models are used to provide dry deposition estimates at the field-scale by combining monitored atmospheric concentrations with inferential modeling. While wet deposition can be measured at the field scale, interpolating to a broader area from site measurements alone can mask spatial variability in precipitation and vegetation diversity impacting throughfall. Monitoring data may be combined with CTMs output to estimate total deposition using MMF techniques as described later in this section. As illustrated in Figure 1 (regional model), CTMs must accurately simulate the fundamental processes that govern the composition of the atmosphere, including emissions, transport, chemical transformations, and ultimately wet and dry deposition. The uncertainties of these processes are inherently linked via the model mass balance and, in the case of deposition, to the process-level algorithms derived from field measurements. It should be noted that MMF techniques described below may not maintain mass balance.

Downscaling deposition estimates from CTMs to specific ecosystems is another important aspect of uncertainty in critical load assessments. Inter- and intra-ecosystem variability in surface characteristics and ecophysiology contribute to large spatial variability in the deposition velocity and fluxes. Typical dry deposition output from CTMs is provided at the grid scale (Figure 1, model grid scale), and is obtained by averaging sub-grid variability in either surface characteristics or dry deposition velocities. The CMAQ model and Global Environmental Multiscale model – Modeling Air quality and CHemistry (GEM-MACH) employ 12 km² and 10 km² grid sizes, respectively, as used in the MMF procedures described below. Use of grid-scale deposition values to assess the critical load of a specific ecosystem may result in large uncertainties due to variability in land cover within the grid cell (Schwede et al., 2018).

In this section we explore the state of the science with respect to these and other sources of uncertainty in total Nr deposition budgets used for critical loads assessments and identify future research activities needed to address the underlying knowledge and data gaps.

Measurement networks that support North American deposition assessments and model evaluation

North American monitoring networks that are used for deposition assessments include sites at which wet deposition is measured directly (Figure 2a) and other air monitoring sites where a

suite of atmospheric concentrations of gases and particulate matter are monitored (Figure 2b). Measurements collected by these networks are used to track spatial and temporal trends in deposition and air concentrations, and therefore play a central role in regulatory accountability. Monitoring networks also provide data that are directly used in deposition assessments, development and evaluation of chemical transport models, and in measurement-model fusion methods. Monitoring networks relevant to atmospheric deposition assessments are further described in the following section.

Wet Deposition Measurement Sites

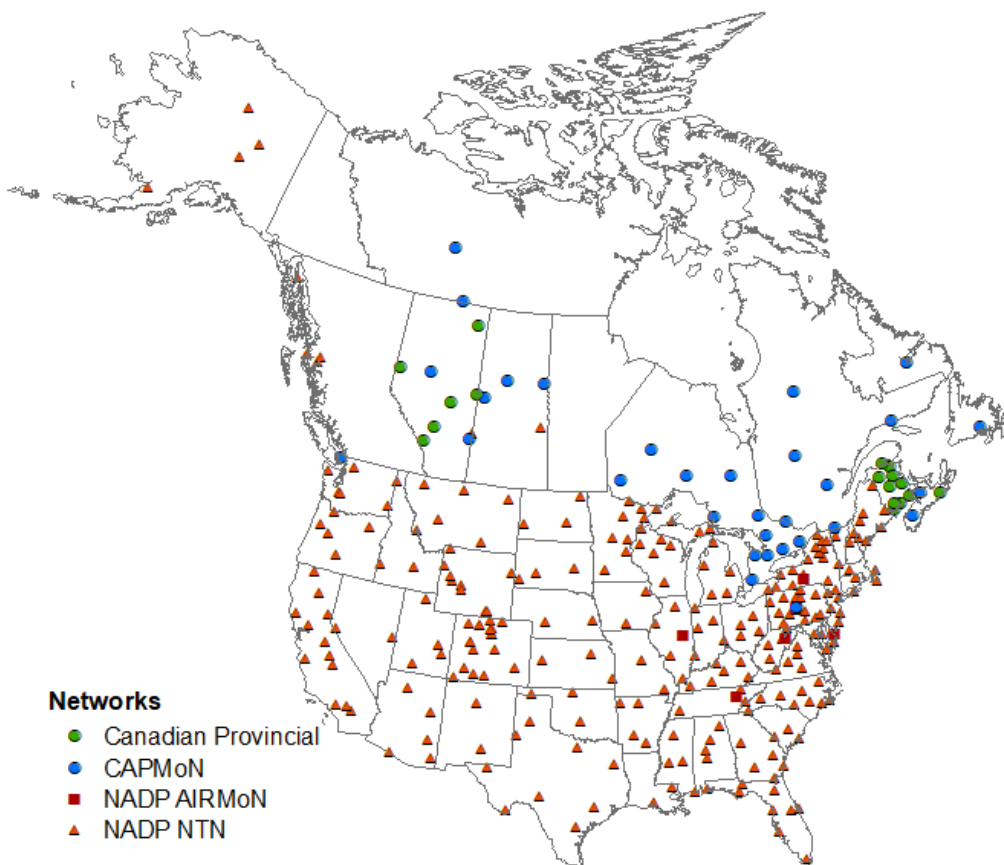

Figure 2a. Map of wet deposition measurement sites in Canada and the conterminous U.S. and Alaska.

Air Monitoring Sites

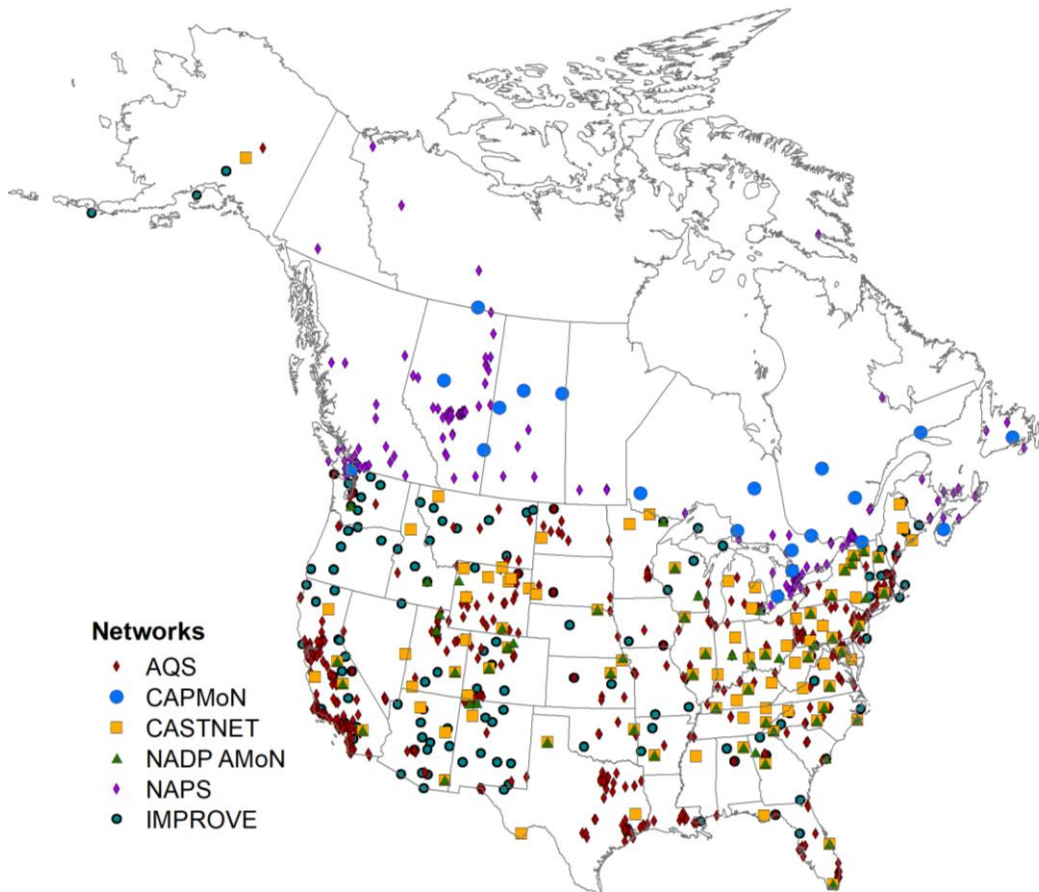

Figure 2b. Map of air monitoring sites in Canada and the conterminous U.S. and Alaska.

Description of networks

The key networks measuring wet deposition and precipitation chemistry are the NADP/NTN, NADP/AIRMoN, and CAPMoN. The NADP/NTN network (<http://nadp.slh.wisc.edu/NTN/>) spans the contiguous U.S. and extends into Canada, Puerto Rico, Mexico, and Alaska. It currently has 257 sites and the program dates back to 1978. The sites collect precipitation-triggered wet-only deposition samples and aggregate precipitation totals. The samples are exposed for week-long periods and are then sent back to a central analytical laboratory and analyzed for dissolved inorganic nitrogen (NH_4^+ and NO_3^-), along with SO_4^{2-} , Cl^- , Br^- , and base cations. The NADP/AIRMoN network (<http://nadp.slh.wisc.edu/AIRMoN/>) has 5 sites and has been operating since 1992. These sites collect daily wet-only deposition samples which are kept refrigerated after collection and analyzed at the NADP central analytical laboratory. The objective of this network is to sample single storm data but for fusion mapping purposes these data are integrated into weekly intervals. The precipitation-chemistry component of the

CAPMoN (<https://www.canada.ca/en/environment-climate-change/services/air-pollution/monitoring-networks-data/canadian-air-precipitation.html>) network provides 24-hour integrated samples of dissolved inorganic N concentrations in precipitation, along with SO_4^{2-} , Cl^- , and base cations. The sampling apparatus for CAPMoN is also precipitation-triggered. The network currently has 29 sites and dates back to 1983.

CASTNET (<https://www.epa.gov/castnet>) and CAPMoN both collect integrated ambient air concentrations of gases and particles using an open-face filterpack cartridge with three sequential filters ordered for particles (Teflon), HNO_3 and partial SO_2 on nylon, and coated cellulose for the remainder of the SO_2 . The same arrangement of filters are used in both CAPMoN and CASTNET, but CASTNET filters are exposed for a week-long period at low flow rates (3.0 and 1.5 L min^{-1} for Western and Eastern sites, respectively) while CAPMoN uses a much higher flow rate (17.5 L min^{-1}) and is exposed for 24-h. There is no explicit particle size cut in either network, although the higher flow rates likely to lead to the capture of larger particles in the CAPMoN protocol. CASTNET currently has 95 rural sites and dates back to 1988. CAPMoN, in addition to the precipitation chemistry sites mentioned above, has 18 sites that collect ambient air concentrations and the network dates back to 1983.

Other air monitoring networks measuring atmospheric N include the NADP Ammonia Monitoring Network (AMoN, <http://nadp.slh.wisc.edu/amon/>), the Interagency Monitoring of Protected Visual Environments (IMPROVE, <http://vista.cira.colostate.edu/Improve/>), several networks that collectively feed data into the EPA Air Quality System (AQS, <https://www.epa.gov/aqs>; <https://www.epa.gov/amtic/amtic-ambient-air-monitoring-networks>) and the Canadian National Air Pollution Surveillance Program (NAPS; <https://www.canada.ca/en/environment-climate-change/services/air-pollution/monitoring-networks-data/national-air-pollution-program.html>).

Out of network samplers

Wet deposition at local or regional scales is often measured with throughfall or bulk deposition samplers which are not part of the networks described above. Samplers collect precipitation in open space (bulk deposition) or under a tree canopy (throughfall deposition) and capture precipitate as either bulk water samples or on ion-exchange resins. The uncertainty of deposition measurements from throughfall samplers is covered in Section **3.1.1.3 Advancing throughfall methods for quantifying N deposition**. In brief, these samplers are mostly used in short term (1-2 years) studies to measure deposition gradients in an area of interest (e.g., from a source to a sensitive area; where negative ecosystem responses have been observed). The value of these collectors is that they are low cost and do not require electricity so they can be placed in remote areas with varied terrain with minimal maintenance. The limitations of using these samplers in a systematic analysis of deposition over time is that each study often has a unique methodology and exposure time to fit the needs of the researchers.

Modeling platforms and approaches used for total deposition estimates in North America

Chemical transport models

In North America, models such as the CMAQ, GEM-MACH and CAMx have been used to provide gridded deposition values for Nr species which are then related to ecosystem response. For example, CMAQ deposition values are used by the Chesapeake Bay National Estuary Program as part of their modeling system that examines progress towards Bay restoration goals. Wet and dry Nr deposition fluxes have been output from different versions of GEM-MACH, both across North America at a 10-km horizontal resolution (Moran et al., 2010) and in regional studies at higher resolution (Makar et al., 2018). The CAMx model was used to examine the contribution of various sources to nitrogen deposition in the Greater Yellowstone area (Zhang et al., 2018) and Rocky Mountain National Park (Thompson et al., 2015). These models provide important information on the Nr budget at regional to continental scales.

CTMs require input values for meteorological parameters, land use and vegetation characterization, and emissions. Meteorological parameters are provided by a meteorological model such as the WRF or the GEM, which may be run as a standalone program or coupled with the CTM as in the case of WRF-CMAQ and GEM-MACH. Meteorological models sometimes use data assimilation to improve model performance but still often have errors in the predictions of parameters such as temperature, surface wetness, and timing and location of precipitation which are important to correctly predicting deposition (Gilliam et al., 2015; Ran et al., 2016).

Both the meteorological models and the CTMs require information on the type of land use within a grid cell and the characteristics of the vegetation including the canopy height, surface roughness, minimum stomatal resistance, and characteristic leaf dimension. Models vary in how this sub-grid information is used, with some using only a dominant land use category or averaging surface characteristics for land use types within the grid. Others use the sub-grid information to calculate fluxes which are subsequently area weighted to calculate the grid value. Most of the models provide land use specific values for parameters such as canopy height and minimum stomatal resistance when, in fact, these parameters are site specific. For example, canopy height for a coniferous forest in North Carolina (average canopy height ~30m) would be the same in some models as the Redwoods in California (average canopy height ~70m). Minimum stomatal resistance is species dependent and using a land use category average value of 200 s m^{-1} , for example, would give a different deposition value than using the value of 100 s m^{-1} typical of maples and oaks vs a value of 300 s m^{-1} typical of birches. Data sets can be developed that provide this level of detail, but they are not currently used by most models. The use of land use specific values contributes to the uncertainty in the deposition values. Additionally, there is lack of agreement between models on what the land use specific values should be, which adds to the variability of predicted deposition.

Models require information on anthropogenic and biogenic emissions, which also contain uncertainty. Anthropogenic emissions are derived from emissions inventories in the U.S.,

Canada, and Mexico and source specific models such as MOBILE6, which provides mobile source emissions. The U.S. EPA provides emission inventories on a 3-year cycle (e.g. 2011, 2014, 2017) with updates to inventories occurring occasionally. Thus, models from the same year can vary based on the timing of the inventory. Emissions from Canada and Mexico are updated less frequently. Models from some major point sources are year specific, but other sources must be interpolated for non-inventory years. Biogenic emissions are modeled using primarily the Biogenic Emissions Inventory System (BEIS) (Bash et al., 2016) or the Model of Emissions of Gases and Aerosols from Nature (MEGAN) (Guenther et al., 2012). These models rely on land cover information and species or plant type specific parameters. Biogenic emissions can vary depending on the model chosen. Wildfire emissions are also important inputs to CTMs and there is still a great deal of uncertainty in the characterization of these emissions.

Another important aspect of modeling uncertainty is in the treatment of atmospheric chemistry. In order to provide reasonable runtimes, CTMs often use chemical mechanisms that are condensations of the Master Chemical Mechanism (<http://mcm.leeds.ac.uk/MCM/> accessed October 9, 2018). Two commonly used chemical mechanisms in North America are the Carbon Bond (Yarwood et al., 2010) and SAPRC (Carter, 2010). In the condensation, species are lumped together and treated with the same chemical properties. Sometimes the lumping has been done due to lack of knowledge of chemistry or existence of certain species. For example, in early versions of the Carbon Bond and SAPRC mechanisms, organic nitrates were treated very simply. Recent studies have provided expanded information and the mechanisms have been updated to include more explicit treatment enabling consideration of a range of properties such as solubility and diffusivity. However, field and chamber studies continue to expand the knowledge of atmospheric chemistry and the models will continue to require updating.

The parameterizations for wet and dry deposition contained in CTMs also contribute to the overall uncertainty in deposition, which is discussed in more detail in Sections **3.1.1.2 Measurement of surface chemistry/wetness relevant to fluxes**, **3.2.1. Application of a bi-directional ammonia air-surface exchange model at NADP AMoN sites** and **3.2.3. Modeling fluxes of reactive nitrogen using chemical transport models**. To the extent possible, deposition parameterizations are based on process level understanding. However, there are not sufficient experimental studies to enable understanding of all processes over all surface and vegetation types. For example, much is known about the stomatal exchange of many gases while much less is known about the exchange between the atmosphere and plant cuticles or the ground or about in-canopy chemistry. Section **3.2.2. Development of in-canopy source/sink models that resolve deposition to ecosystem components (crown, understory, ground) and in-canopy chemistry** provides some additional information on uncertainties in the in-canopy exchange processes and Section **3.1.1.5 Snow and atmospheric deposition** discusses the difficult area of exchange between the atmosphere and snow-covered surfaces.

Measurement-model fusion

Since evaluations of CTMs have shown errors and biases in predictions (e.g. Appel et al., 2018), MMF approaches are increasingly being used to provide deposition values. In MMF, the predictions from a CTM are combined with air concentrations from network measurements. In the U.S., the TDep MMF approach was developed as part of the activities of the NADP Total Deposition Science Subcommittee. The TDep approach (Figure 3) uses data from CMAQ combined with data from CASTNET to develop bias adjusted air concentrations using inverse distance weighting that are combined with CMAQ deposition velocities to produce dry deposition values for measured species (i.e. gas phase HNO_3 , SO_2 , and particulate SO_4 , NO_3 , NH_4 , Ca, Cl, K, Mg, Na). For species not measured at CASTNET sites (i.e. gas phase NO , NO_2 , HONO , N_2O_5 , NH_3 , PANs, organic nitrates), the CMAQ dry deposition values are used directly. Dry deposition for the measured and unmeasured species is combined to quantify total N_r and S dry deposition. These are combined with wet deposition values from NADP NTN to produce values of total deposition of S and N_r for the contiguous U.S. More detailed information is available from <http://nadp.slh.wisc.edu/committees/tdep/tdepmaps/> (last accessed October 9, 2018).

A slightly different approach has been developed by the Environment and Climate Change Canada (ECCC) project ADAGIO where maps of optimized wet, dry and total annual deposition of N_r, S, and ozone in Canada and the U.S. are generated by combining observed and modelled data (Figure 4). The analysis is done on a seasonal basis and summed to calculate the annual totals.

For N_r, measured concentrations of gas-phase HNO_3 , NO_2 , NO , and NH_3 ; particulate NO_3^- and NH_4^+ ; and NO_3^- and NH_4^+ in precipitation from Canadian and U.S. networks are used to adjust predicted concentrations from GEM-MACH using optimal interpolation techniques. Optimal interpolation is essentially a statistical method for minimizing the differences between the model and measurements, with some built-in quality control procedures. This process generates maps of air and precipitation concentrations at a 10-km resolution.

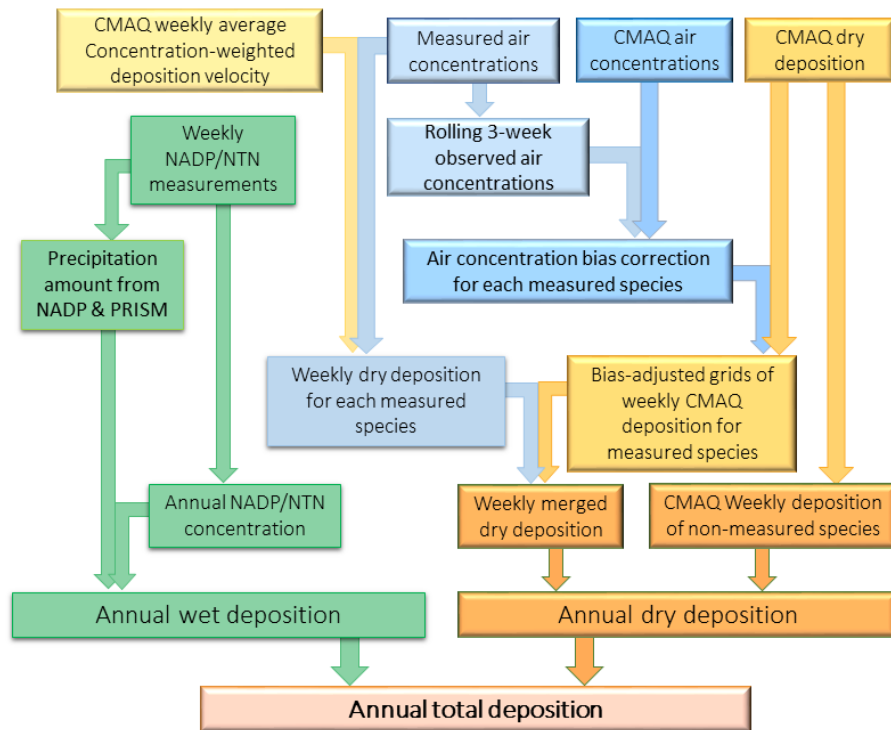

Figure 3. TDep method overview (Schwede and Lear, 2014).

Dry deposition velocities derived from GEM-MACH are then applied to the adjusted concentration grids of gas and particle species to generate deposition fluxes of measured species. Dry deposition fluxes of unmeasured species, specifically N_2O_5 and organic nitrates, are taken from the model directly. Wet deposition fluxes are calculated using precipitation amounts from the Canadian Precipitation Analysis (CaPA) used at ECCC. CaPA uses the GEM weather forecast and adjusts daily precipitation amounts using climate station and radar observations, also using optimal interpolation methods.

ADAGIO results for the development year, 2010, have been completed, and the next expected year with updated GEM-MACH emission budgets will be 2016. Beginning in 2018, GEM-MACH deposition fields will be archived for ongoing annual ADAGIO maps.

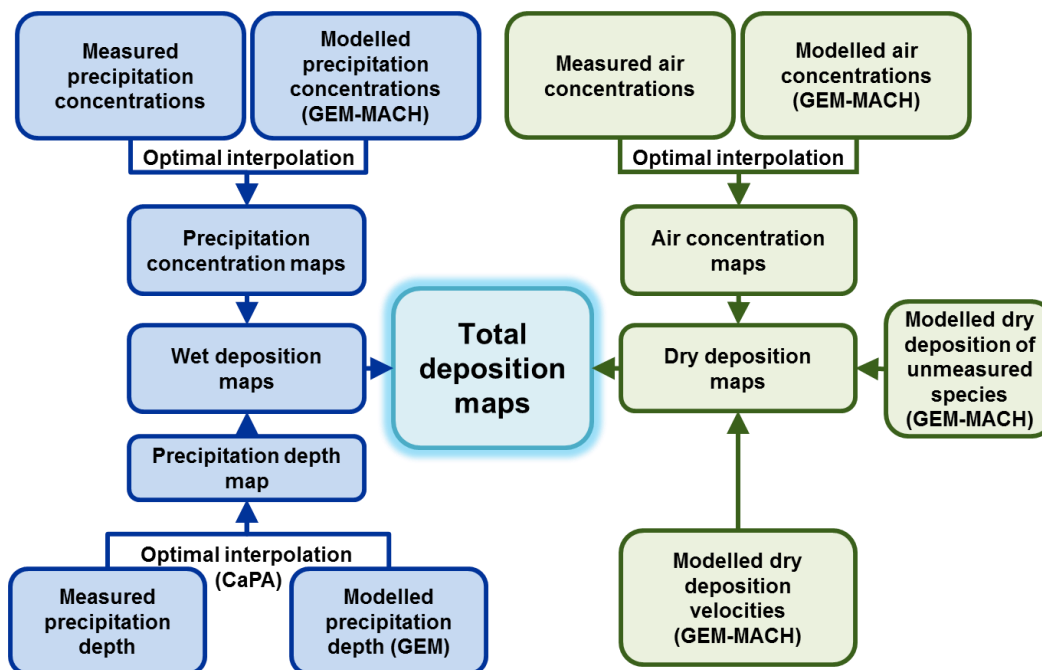

Figure 4. ADAGIO method overview.

State of the science

Critical loads for different ecosystem components may be calculated using the variety of deposition measurements and models described above. For the critical loads to be combined in a single analysis for policy or management action, it must be clear how the deposition values used relate to one another so that the data can be properly synthesized and relevant uncertainties can be described.

Completeness of deposition budgets

As noted above, North American monitoring networks that support deposition research characterize only the inorganic fraction of wet deposition and atmospheric concentrations of particles and gases and are thus incomplete with respect to speciation of the complete atmospheric Nr pool. Several key compounds or groups of compounds are not measured yet are known to contribute significantly to Nr deposition budgets. These include organic compounds in the gas and particulate phases and additional inorganic oxidized compounds such as NO₂. Globally, ON compounds contribute ~ 25% of total water-soluble Nr in precipitation on average (Jickells et al., 2013), with a similar fraction observed in PM (Cape et al., 2011). In the U.S, annual averages for rainfall and PM range from 2.6% to 33% of total N as ON (Scudlark et al., 1998; Keene et al., 2002; Whitall and Paerl, 2001; Beem et al., 2010; Benedict et al., 2012; Walker et al., 2012; Zhang et al., 2002; Russell et al., 2003; Calderon et al., 2007; Lin et al., 2010; Zamora et al., 2011; Chen et al., 2018). With respect to oxidized forms of

Nr, NO₂ may contribute a significant portion of Nr deposition within and downwind of urban areas (Cheng et al., 2013).

Due to the incompleteness of measured deposition budgets, estimates of total deposition are derived from models or from hybrid approaches that combine measurements with models (e.g., TDep and ADAGIO). Figure 5 is an NADP TDep map of the dry deposition contribution of unmeasured (i.e., “other”) compounds to total Nr deposition, which includes NO, NO₂, HONO, N₂O₅, and ON. As predicted by CMAQ (Version 5.0.2), this fraction contributes an average of ~13% of the budget over the contiguous U.S., with larger contributions particularly in the eastern U.S. where NO₂ from mobile sources is important.

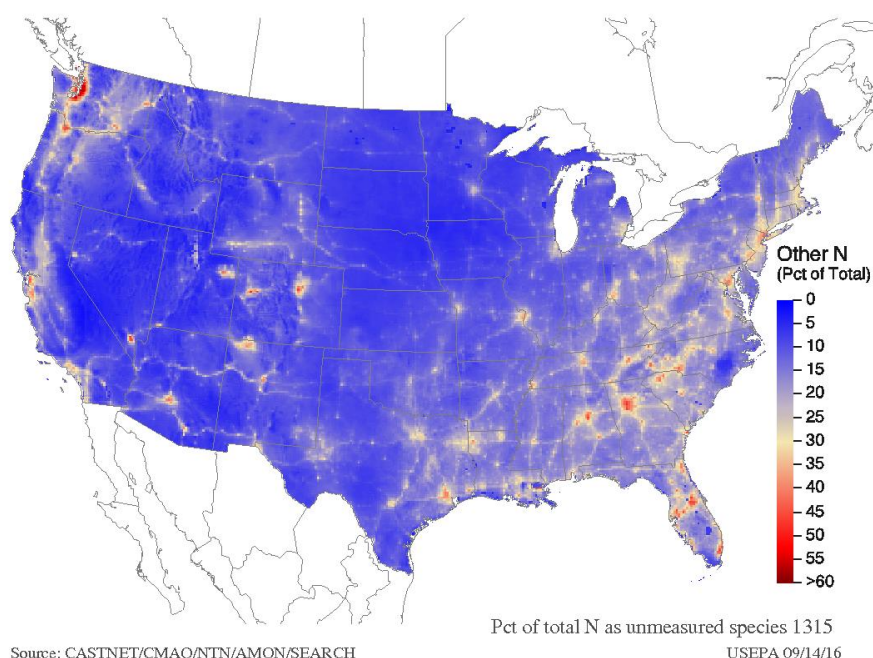

Figure 5. NADP TDEP map of the contribution of “other” N to total Nr deposition. “Other” N represents unmeasured compounds and comprises NO, NO₂, HONO, N₂O₅, and ON.

This “other” portion of the modeled Nr deposition budget is significant yet highly uncertain, motivating a need for additional measurements of bulk organic Nr and NO₂ deposition for model evaluation. Regarding ON, it should be noted that CMAQ V5.0.2 includes only PAN, aromatic PANs (OPAN), C3 and higher PANs (PANX), and some organic nitrates in the gas phase. Thus, the organic fraction of nitrogen dry deposition represents an underestimate. Wet deposition of organic N is not well represented in CMAQ V5.0.2 due to a limited range of solubilities specified for organic nitrates. Total wet deposition of Nr is therefore underestimated by an unknown amount in the TDep maps. In GEM-MACH, only PAN is treated individually, with an additional grouped “organic nitrates” species, and therefore is subject to

similar limitations as CMAQ. Chemical mechanisms used with many CTMs have recently been updated to include more advanced treatment of organic nitrate species (Luecken et al, 2019). ON is discussed in more detail in Section **3.1.2.5. Characterization of organic nitrogen in air and precipitation.**

Accuracy of deposition estimates

Measurement to model comparisons

Network collectors offer the best opportunity for comparisons across large spatial scales, while collectors in small projects generally evaluate local or regional deposition gradients. The NADP NTN uses precipitation collectors with a sensor to only open the collector during a precipitation event, which produces wet deposition only measurements. The network places all of its collectors in open space, thus may underestimate the amount of deposition in cells with high forest cover. Bulk collectors are generally consistently open to the atmosphere so they collect a mix of wet and dry deposition. These are deployed for short periods that often correlate with the wet/dry or snow/rain precipitation seasons. This creates a challenge to compare to models since the dates of deployment do not always correspond with standard model outputs (calendar year). Additionally, throughfall measurements are often made under a single tree species at a site, don't always take tree size into account, and do not capture stemflow (for a full analysis of uncertainty in throughfall deposition measurements, please see Section **3.1.1.3 Advancing throughfall methods for quantifying Nr deposition**). Due to these uncertainties, throughfall samplers have rarely been compared with CTMs, but where they have been evaluated, TDep estimated deposition varied between -2% to 550% of throughfall measurements in forests in the western U.S. (Schwede and Lear 2014), and the wet Nr deposition bias in the Pacific Northwest approached or exceeded regional diatom and lichen critical load values at several NADP-NTN monitoring sites (Williams et al., 2017). This highlights the importance of developing comparisons of wet deposition samples in multiple ecosystems to understand the consistency of model/collection bias across various sensitive ecosystems.

The dry component of Nr deposition is not directly measured in a routine monitoring mode in North America. While deposition budgets developed for assessment of critical loads primarily rely on measurements for the wet component, dry deposition is modeled. Direct measurement of dry deposition requires the use of micrometeorological flux measurement methods (e.g, EC, aerodynamic gradient, relaxed eddy accumulation) deployed above the vegetation canopy, which requires significant infrastructure particularly in the case of forested sites. Sampling and analytical methods for Nr flux measurements are costly and often labor intensive. For these reasons, micrometeorological flux measurements are typically conducted for short periods of time to examine deposition processes rather than for extended periods of time needed to develop annual deposition budgets. Historically, North American flux datasets used for development and evaluation of dry deposition algorithms for Nr have been relatively limited in temporal extent, covering a few weeks to a full calendar season or growing season (HNO_3 ,

Meyers et al., 1998; HNO₃, Brook et al., 1999; NH₃, He et al., 2013; PAN, Wu et al., 2012; NH₃, Pleim et al., 2013). An exception for North America is the dataset developed by Munger et al (1996) for the Harvard Forest, which represents multiple years of oxidized Nr fluxes. A detailed review of North American Nr flux measurements is provided in Section **3.1.1.1. Measurements of air-surface exchange of Nr in natural ecosystems across North America**.

Model to model comparisons

Spatially continuous estimates of Nr deposition are often only available from air quality models, or from products that combine model output with measurement data. However, models vary widely in their emission inputs, horizontal and vertical resolution, time periods simulated, and the chemical and physical processes represented. Multi-model comparisons can provide an overall estimate of the resulting variability in output parameters. A number of global- and continental-scale model intercomparison projects have assessed Nr deposition among other air quality outputs. Two pieces of information about the uncertainty of model estimates of Nr deposition can be gained from these studies. First, how different are the models in their estimates of deposition? And second, how well do the models, or the average of all the models, reproduce measurement data?

In the PhotoComp study for the year 2000 (Dentener et al., 2006), the variance of modelled total NO_y deposition between the 23 models assessed was 10-30% across most of North America. While a corresponding spatial breakdown was not shown for NH_x deposition (reported by only 7 models), the variance was similarly reported to be about 30% in the anthropogenic emissions regions including North America. The Atmospheric Chemistry and Climate Model Intercomparison Project (ACCMIP) reported similar variance between models of 20-30% in wet and dry deposition of both NO_y (10 models) and NH_x (5 models) for the year 2000, integrated over North America (Lamarque et al., 2013). In contrast, in the AQMEII study which modeled 2006, the estimated total deposition of NO₃⁻ in North America from 5 different models had a variance of more than 50% (Solazzo et al., 2012). However, in that case, the emissions used by each model were not identical.

Typically, measurement data were compared with the multi-model mean in each intercomparison. When comparing annual wet deposition of NO₃⁻ and NH₄⁺ with NADP measured values, the mean models performed well, mostly within 10-20% of measurements as shown by the slope of the model vs. measurement linear fit (Table 1) and the reported mean biases of 11-38% for NO₃⁻ and <8% for NH₄⁺ (summarized by Tan et al., 2018). The exception was the underprediction of NH₄⁺ deposition in ACCMIP, with a slope of 0.5. Even in that case, 76% of the model values interpolated to the measurement sites were within 50% of the measured values. While individual models may perform better for specific locations and/or chemical species, in general, the ensemble of the models is the most robust estimator of wet deposition when considering all species and regions (Dentener et al., 2006; Tan et al., 2018).

Model predictions of dry Nr deposition (oxidized and reduced) were also compared with inferential values based on air concentrations at CASTNET sites in a limited number of studies. When species such as NO₂ and NH₃, which are not included in the measurement data, are included in the modeled dry deposition, the model was higher than the inferential values by about a factor of 3 (Vet et al., 2014). However, excluding the NO₂ and NH₃ dry deposition from the model totals in another study left the model dry Nr deposition values still higher by a factor of 2 compared to CASTNET inferential estimates (Tan et al., 2018). Further investigation of the two components of dry deposition revealed that it was primarily the air concentrations of HNO₃, particle NO₃⁻, and particle NH₄⁺ that were overestimated in the model compared to the CASTNET measurements, rather than significant differences in the dry deposition velocities. Some of this discrepancy may be due to the coarse resolution of many of these global models (Tan et al., 2018). Generalizing results from the studies summarized here, model differences in wet deposition are ~ 30% for wet deposition and ~ 100% or more for dry deposition.

Table 1. Evaluation of multi-model mean wet deposition values with NADP measurement data. For all parameters, the ideal value is 1.0.

Project	Year	NO ₃ wet dep			NH ₄ wet dep		
		Linear fit slope	Correlation coefficient	Fraction within 50%	Linear fit slope	Correlation coefficient	Fraction within 50%
PhotoComp	2000	1.1	0.8	0.76	1.0	0.8	0.67
ACCMIP	2000	0.9	0.9	0.69	0.5	0.8	0.76
HTAP I	2000	1.0	0.9	0.84	0.9	0.9	0.85
HTAP II	2010	1.2	0.9	0.67	0.8	0.9	0.88

Dry deposition algorithms

As noted above, uncertainty in dry deposition is generally much larger than wet deposition, owing the higher degree of complexity in dry deposition parameterizations and a lack of fundamental understanding of many of the important dry deposition processes. Recent assessments in Europe (Flechard et al., 2011) and the U.S. (Schwede et al., 2011; Li et al., 2016) show that commonly used field-scale inferential models may differ by a factor of 2 or more in mean deposition (exchange) velocities of Nr species, despite being driven by the same on-site meteorology and parameters for site characterization (e.g. leaf area index, surface roughness length, canopy height, etc.). Nr species exhibit a range of physical and chemical properties, leading to very different behaviors in the dry deposition process, which is often described via a deposition velocity (V_d) modeled as:

$$V_d = 1/(R_a + R_b + R_c) \quad (1)$$

where R_a is the aerodynamic resistance to turbulent transfer from the atmosphere to the surface, R_b is the resistance to diffusion across the laminar boundary layer of air immediately above the receptor, and R_c is a resistance to uptake at the receptor surface, termed the canopy resistance. For some fast-depositing chemical species such as gaseous HNO_3 , which has near-zero R_c , the deposition velocity is governed by R_a and R_b (i.e., the atmospheric resistances). Wu et al. (2018) intercompared five dry deposition algorithms and found that the four models based on Monin-Obukhov similarity theory (MOST) produced very similar ($\pm 20\%$) results for R_a and R_b . In contrast, the multilayer model (MLM) used at CASTNET sites, which takes a practical approach and uses routinely measured wind speed and direction, had 4–5 times higher R_a and R_b than those of the MOST-based models.

Surface uptake, represented by R_c , may take place both through leaf stomata and onto other surfaces (e.g., ground, leaf cuticle, woody material). For gas phase Nr species other than highly soluble species such as HNO_3 and N_2O_5 (e.g., NO_2 , PANs), R_c is typically the largest in magnitude among the three resistances and thus controls V_d . R_c for Nr species can also exhibit relatively large differences across deposition models (Wu et al., 2012), leading to substantial differences in deposition estimates. The stomatal models popular in the land surface and climate communities are also used in the deposition schemes, following either the Jarvis or the Ball-Berry approaches to estimate the stomatal uptake of Nr (Ball et al., 1987; Jarvis et al., 1976). Non-stomatal uptake is more challenging to parameterize and usually leads to larger differences in model estimated deposition velocity (Wu et al., 2012), because flux uptake by the non-stomatal pathway cannot be measured directly or segregated from canopy scale flux measurements. Thus, non-stomatal deposition processes are the least understood and therefore the most highly parameterized and uncertain. Adoption of a bidirectional flux framework for NH_3 , which is now common in CTMs, requires the use of compensation point parameterizations (e.g., soil and vegetation emission potentials) that remain poorly characterized for many ecosystems, leading to large uncertainty in NH_3 dry deposition rates at the local scale (Dennis et al., 2013). Parameterization of emission potentials and surface resistances for NH_3 are largely derived from European experiments (Massad et al., 2010; Zhang et al., 2010) and their applicability to North American ecosystems remains an open question.

Measurement-model fusion

There are several sources of uncertainty in MMF estimates of deposition including the observational data, the choice of CTM, and the fusion approach. The observational data sets are a key component of the MMF process as they serve to bias correct the CTM values. The measurements used in the MMF approaches and the model evaluations are from national monitoring networks in both the U.S. and Canada. The two main fusion methods considered here are ECCC's ADAGIO model and the NADP's TDep method. The ADAGIO method, as described above, spans Canada and the U.S. and uses daily and weekly integrated measurements of wet deposition and precipitation from the federal precipitation chemistry network CAPMoN and provincial networks, NADP/NTN, and NADP/AIRMoN. The TDep method

uses weekly integrated measurements of precipitation from NADP/NTN and NADP/AIRMoN sites. For dry deposition estimates, ADAGIO uses ambient filterpack concentrations from CAPMoN and weekly filterpack concentrations measured by CASTNET. The TDep method relies on only the CASTNET measurements. The ADAGIO analysis also includes biweekly NH₃ from AMoN and hourly chemiluminescence measurements of NO and NO₂ from the national criteria pollutant databases, EPA's AQS and Canada's National Air Pollution Surveillance Program (NAPS).

As the measurement networks (excluding NAPS and AQS) were designed to be regionally representative, the data used is primarily collected at rural sites and not representative of urban areas. Measurement data that is selected for inclusion in the fusion methods should be subject to rigorous quality assurance procedures to ensure its accuracy and consistency. Additionally, the measurements should be conducted over the long-term to maintain comparability for inter-annual comparisons and to identify long-term trends. An example is measurements from the Southeastern Aerosol Research and Characterization (SEARCH) network which were included in TDep maps up until the most recent version (2018) as the SEARCH network was discontinued in 2016. SEARCH data was removed entirely from the set of maps spanning from 2000-2016 to prevent artifacts in annual comparisons as the measurement site locations change from measurement-derived to model-derived. A similar artifact can occur from year to year when specific sites meet or fail to meet completeness criteria.

Due to the bidirectional treatment of NH₃ in CMAQ, TDep does not currently fully incorporate NH₃ measurements from NADP/AMoN into the fused estimates, but uses the data for model evaluation purposes. Research is underway to improve bidirectional models so that these data can be incorporated directly into the method (see Section **3.2.1. Application of a bidirectional ammonia air-surface exchange model at NADP AMoN sites**).

In comparing gridded values and point estimates, the incommensurability of volume-average concentrations and pointwise observations needs to be considered (Swall and Foley, 2009). For some chemicals, there can be a high degree of spatial variability within a model grid cell that is not captured by the model but may be captured by the point value. If multiple observations across a grid were averaged and then compared to the model value, a very different value for model bias might be determined. There can also be temporal differences between modeled values and observed values. Modeled values are typically available on an hourly basis while network data may be temporally averaged. Important cross-correlations can exist between concentration values and deposition velocities. If temporally averaged (e.g. 3-day, weekly, biweekly) values are used, this correlation needs to be considered. Observational values are spatially, temporally, and chemically incomplete, depending on the networks used in the MMF. Data gaps can affect the resulting MMF results (see Section **3.1.2.1. Wet deposition annual precipitation-weighted mean concentrations from incomplete time series: Influence of completeness criteria, data validation, and data substitution methods**). For example, the TDep approach relies only on CASTNET data to bias correct CMAQ model concentration values used

to determine dry deposition. In some regions of the country, CASTNET sites are sparse, which can create artifacts in the bias surfaces. Another issue is temporal completeness of data. Quality assurance and completion criteria are applied to measured values which can cause data to be flagged as invalid, resulting in a temporal gap. Sites that are not temporally complete can cause artifacts in the MMF surfaces. Finally, observed values are not available for all chemicals. So, some important model species like ON are not bias corrected in the MMF methods.

The CTM is an important component of the MMF approach. Since, as noted above, there is variability between models in their deposition values, the choice of CTM and even the version of the CTM adds uncertainty to the MMF result. The MMF processes used for TDep and ADAGIO are not tied to a particular model and the approaches could be applied for the results from multiple CTMs. For example, results from CAMx could be used in place of CMAQ in the TDep method. Since CAMx and CMAQ contain different deposition algorithms (as well as other model differences), MMF output would be different depending on the CTM selected. CTMs are continually being updated as advances in scientific understanding are incorporated into the models. Using the same CTM, but a different version, can also change the MMF results. In the case of the TDep maps, updates were made in 2016 to use the CMAQ output from a decadal time series of runs of CMAQ v5.0.2 for 2002-2012 rather than the output from CMAQ v4.7 that was used for prior versions. Moreover, CMAQ v5.3 will be released in Spring 2019 and outputs will be made available for use in the TDep maps. Figure 6 shows a comparison of the bias surface constructed based on comparing HNO_3 concentrations from CMAQ versions 5.0.2 and 5.2 with CASTNET measurements for 2011. While in some parts of the U.S., the bias is very similar between the models, it is quite different in other areas due to updates in many of the model features. Significant resources are needed to run the model, so regenerating a long time-series of runs for each new model version is difficult. However, using the bias surfaces to combine runs from different models or different model versions poses some difficulties. As noted above, there are areas of the U.S. with few CASTNET monitors, which makes the bias surfaces created using that network somewhat uncertain. Also, bias surfaces are not available for all chemicals which means only a portion of the budget is being adjusted; this may amplify mass balance inconsistencies. Additional analysis is needed to examine the relative impacts of using the limited bias surfaces to combine runs from different model versions versus, perhaps, running the same model version for only a few years and temporally interpolating the values to construct the needed time series.

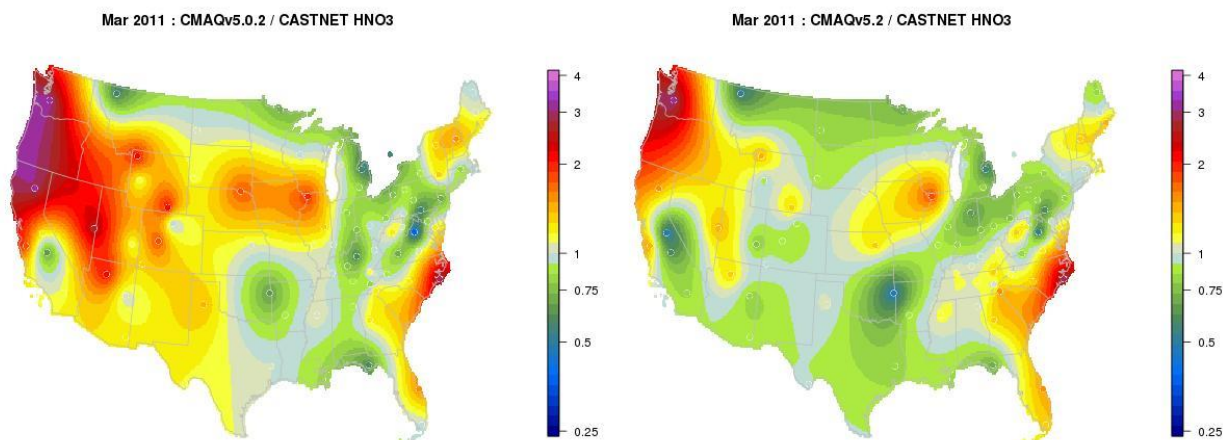

Figure 6. Gridded bias surfaces for HNO₃ for March of 2011 comparing CMAQ versions 5.0.2 and 5.2.

Completing model runs relies on having appropriate emissions and meteorology inputs. While meteorology is usually available in near real time, the release of emission inventories often lags several years which delays model runs. For TDep, the most recent CASTNET and NADP measurement data for 2013 to 2017 use the most recent CMAQ estimates for the v5.0.2 time-series (2012), creating a divergence between model and observation years. As this divergence grows, the uncertainty increases. Error evaluations performed by Lear (2017) compared 2005 CMAQ runs with CMAQ runs from “lag” years 2006 through 2010 to assess the stand-alone error caused by the model-measurement year divergence. Results suggest that additional error due to the discordant CMAQ model years is relatively low (2.1 to 3.6% median absolute relative percent difference (MARPD)) for dry deposition and less (1.3 to 2.3% MARPD) for total deposition of Nr compounds. The trend suggests that the error increases slightly with each discordant year. However, this error increases from 13 to 27% MARPD for dry S deposition and 5.4 to 10.9% MARPD for total S deposition with substantial increases in annual increments. This was attributed to the significant reductions in SO₂ emissions during that time.

The choice of MMF methods is also an area of uncertainty. The TDep and ADAGIO methods are two examples of approaches that could be used, but others could be implemented. The two approaches have differences in the observational data used and the interpolation methods. Also, within each of these methods there are parameters, such as the distance to consider for inverse distance weighting, that will impact the MMF results. Additional analysis, some of which is underway, is needed to quantify the impact of using the TDep vs the ADAGIO method and the sensitivity of the approaches to the specification of individual parameters.

Biomonitoring deposition

Instead of developing an extensive infrastructure of monitors, another option is to utilize bioindicators of deposition to understand local and regional deposition patterns. Measurements of deposition can be made at sites paired with an analysis of a sensitive

ecosystem component to extrapolate deposition across the species population range. Epiphytic lichen communities have been used to track deposition of various pollutants because they grow on rocks, tree trunks, and boles (and anthropogenic structures) and get their nutrients from air and rain water. This allows for direct comparison to atmospheric concentrations, since external nutrient cycling is limited, and the evaluation of cumulative deposition to an area based on either species nutrient composition or presence.

Each lichen species has a unique response to increasing deposition levels. Some increase their nutrient contents, while oligotrophic species decrease in abundance with increasing deposition and eutrophic species increase (Geiser et al., 2010). To evaluate regional deposition, Root et al. (2013) compared lichen nutrient content to throughfall deposition measurements in the Pacific West and developed a model to estimate deposition. At a local scale, Bermejo-Orduna et al. (2014) used nutrient content of lichen to assess steep deposition gradients from an interstate highway. Additionally, N content can be paired with concentrations of other ions to refine model estimates (Will-Wolf et al., 2017). From a community perspective, biomonitoring models have also used lichen community analysis from USDA Forest Inventory and Analysis (FIA) plots to predict deposition in hard to reach places (Jovan, 2008; McMurray et al., 2015), and with over 5,000 FIA plots across the U.S. there is the possibility of expanding this method.

Representativeness of deposition estimates

Typical dry deposition output from CTMs is provided at the grid scale and is obtained by averaging sub-grid variability in either surface characteristics or dry deposition velocities. Figure 7 illustrates the sub-grid treatment of the mosaic of land use types within a grid that is typical of many CTMs. The CTM does not spatially resolve the land use types, designated here using the National Land Cover Database (NLCD) as a generic example, within the model grid and only has knowledge of the percent coverage of the land use type in the grid (represented by the pie chart in Figure 7). Differences in LAI, surface roughness, and plant stomatal response are some of the factors that contribute to sub-grid variability in the deposition velocity. The degree of sub-grid variability is also dependent on the chemical species. For chemicals such as NH_3 that exchange bidirectionally with the atmosphere, gridded values that either ignore bidirectional exchange, or don't consider the potentially compensating contributions of upward and downward fluxes across the heterogeneity of a grid cell when determining a grid cell average value will be quite different than those that do consider these processes as well as the land use specific value. This dichotomy is represented by the unidirectional and bidirectional pathways in Figure 7.

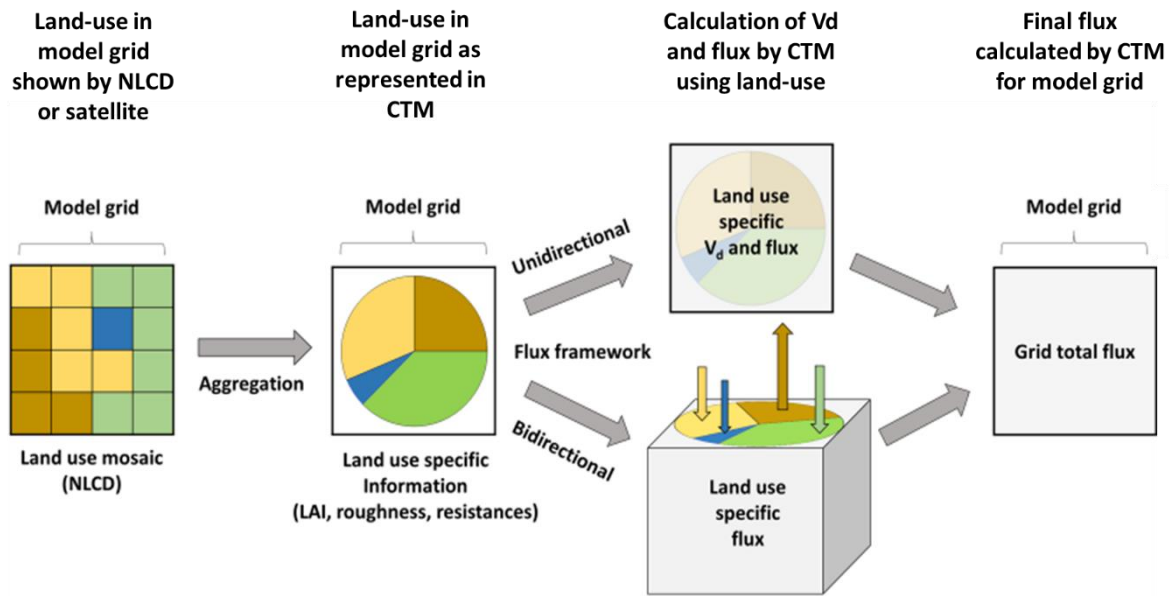

Figure 7. Illustration of MOSAIC approach for estimating land use specific deposition velocities and fluxes in a gridded CTM.

Flechard et al (2011) examined the deposition velocity of 5 N species predicted by 4 CTMs over 4 land use types and found differences of a factor of 2 or more between land use types, depending on the chemical. Generally, the deposition velocity to a forest is higher than other land use types, primarily due to the higher LAI and surface roughness. This is particularly true for HNO_3 which often constitutes a significant portion of the Nr budget. Several recent publications have begun to look at the impact of downscaling the gridded values to provide ecosystem-specific values of deposition. Schwede et al. (2018) examined deposition to global forests and contrasted values based on grid-base estimates with land-use specific values as predicted by the European Modeling and Evaluation Program (EMEP) model (Simpson et al., 2012) and found differences in deposition of as much as a factor of 2 between the two values. The differences in deposition between the grid-average value and the forest-specific value for a particular grid cell depended on the degree of heterogeneity in grid cell. Paulot et al. (2018), developed downscaled deposition values from the coarse-resolution of the NOAA Geophysical Fluid Dynamics Laboratory (GFDL) model to land-use specific values for current and future scenarios. Their results indicate that grid-based results from coarse scale models may underestimate deposition to natural vegetation by up to 30%.

Given the results of these studies, use of gridded deposition values for comparison against ecosystem-specific critical loads values can contribute to the uncertainty in the evaluation of exceedances. Since deposition to individual land use types within the grid cell may be higher or lower than the average value for the grid, it is important to use the ecosystem-specific deposition value. Options for land-use specific deposition output are becoming available in

CTMs, such as the Surface Tiled Aerosol and Gaseous Exchange (STAGE) deposition module in CMAQ v5.3 (Bash et al., 2018).

Future research

In this section we outline several areas of research that would address aspects of uncertainty in Nr deposition budgets described above and attempt to distinguish efforts that could be accomplished in the near term versus those that will require longer term study.

Near-term

Compilation of databases of non-network deposition measurements for model development and evaluation - Compilation of databases of non-network deposition measurements, including throughfall and direct dry deposition measurements, is feasible in the near term. Efforts are underway to develop a database of throughfall measurements across North America. While most CTMs are developed using wet deposition measurements from NADP, this throughfall database will provide an opportunity to evaluate models against independent non-network measurements, facilitating further assessment of uncertainty in models used for deposition assessments, with the known caveat that throughfall represents the lower limit of total deposition. A second effort is underway to construct a global metadatabase of micrometeorological flux measurements of Nr (i.e., dry deposition). The purpose of this effort is to establish a publicly available, searchable archive that can be queried to easily assess where and when measurements of reactive chemical fluxes have been conducted. While this information is easily accessible for more routine measurements (e.g., wet deposition, air concentrations) collected within networks, direct measurements of air-surface exchange of particles and trace gases (i.e., dry deposition and bidirectional exchange) are typically conducted in intensive, shorter-term studies. These datasets are therefore often less visible and accessible to the user community. Establishment of a publicly available metadatabase for Nr flux measurements would serve the atmospheric science and ecological communities interested in better understanding the processes and drivers of land-atmosphere exchange of Nr and development of models to better simulate these processes.

Comparison of CTMs - Following on the model intercomparisons discussed above, the next (fourth) phase of the AQMEII study will focus on evaluating model performance for atmospheric deposition of Nr, S, and ozone. Output parameters related to wet and dry deposition that were not necessarily retained in previous studies, such as the resistance parameters for dry deposition velocity calculations, could be compared between multiple models to help identify the largest sources of variability in deposition. Mapping this variability between models will yield an updated estimate of uncertainty for deposition. Model runs under AQMEII-4 are planned for 2019, and results will follow over subsequent years. In addition to deposition output, other analyses could be conducted to assess which model components

contribute most to total uncertainty (e.g., meteorology, surface physical characteristics, atmospheric chemistry).

Comparison of MMF approaches - Since modeled values are being used to determine critical loads and exceedances within federal land units, it is important to understand where different CTM values align and diverge from one another. In theory, methods such as TDep and ADAGIO that combine measurements and modeling information yield the best possible continuous fields of total Nr deposition available at this point. Given that, a comparison of how much the two methods differ, where they overlap in the contiguous U.S., would provide a quantitative estimate of the uncertainty in estimated deposition. It is expected that they will be most similar in the vicinity of measurement sites, since the data used by both methods is the same, and where wet deposition dominates, since modeled dry deposition velocities can be quite different. They will likely diverge where the estimates are largely model-based, where dry deposition dominates, and/or where unmeasured species comprise a larger fraction of the deposition. At a land unit level, it is important to understand how consistently these divergences align with specific landcover types to understand the uncertainty that exists for different ecosystems. It should be noted that using this comparison to assess uncertainty is not appropriate for finer-scale evaluations (for example, in a region smaller than 1000 km²) given the grid sizes of the two methods. This comparison can be done in the near future for 2010, the only year currently completed for ADAGIO; additional years can follow as new grids are generated.

Assessment of sub-grid variability of deposition in CTMs – The CMAQ STAGE approach could be used to quantify differences in grid averaged versus land-use specific deposition velocities and fluxes across a range of land use mixes and ecosystem characteristics. Such an analysis would inform the potential range of uncertainty resulting from the use of grid-average fluxes in MMF approaches, for example.

Expansion of lichen biomonitoring models – Current lichen-based deposition models have been restricted to regional analyses where similar lichen communities exist. FIA lichen surveys have been completed across the U.S., including Alaska, which will allow for a more extensive model to be created. Early efforts are being conducted by the USFS to compare lichen communities to CMAQ model outputs. This analysis will then allow for future comparisons between other CTMs to determine uncertainty in the estimates.

Long-term

Further development of methods to incorporate satellite data into measurement-model fusion approaches – Exploration of the use of satellite data in measurement-model fusion approaches is needed. This could include the use of satellite data for evaluation of model concentration fields, particularly for species such as NO₂ and NH₃ which are highly spatially variable, and potentially to refine the spatial weighting of measurement versus modeled concentrations

during the fusion procedure. In this context, satellite data may inform the expansion of ground-based monitoring to fill geographical gaps.

Flux measurements to examine trends and improve dry deposition algorithms - Establishment of long-term sites for reactive chemical flux measurements across different ecosystems and deposition regimes is needed for improving dry deposition models and calibrating throughfall measurements. Flux measurements that elucidate non-stomatal processes and the importance of in- and near-canopy chemistry on net atmosphere-biosphere exchange are considered high priorities. Low-cost time integrated direct dry deposition methods such as the COTAG technique (Famulari et al., 2010) could be deployed in a monitoring mode to quantify dry deposition for seasonal and annual deposition budgets and to provide additional data for evaluation of inferential dry deposition models. Knowledge gaps and research priorities related to direct flux measurements and flux methods are described in more detail in Sections **3.1.1.1 Measurements of air-surface exchange of Nr in natural ecosystems across North America** and **3.1.2.4 Low-cost method for routine monitoring of air-surface exchange of Nr compounds**.

Measurement of bulk ON in monitoring networks - The most expeditious approach for expanding measurements of bulk ON in North America and to establish standard methods is to utilize existing monitoring infrastructure. A long-term goal would be to incorporate routine measurements of bulk ON into NADP, CAPMoN, and CASTNET sampling and analytical protocols. Near-term objectives would focus on methodological details. For precipitation measurements, stability of ON during sampling and storage is a priority. Additional effort is needed to develop a method suitable for collection of weekly precipitation samples to facilitate leveraging of the NTN infrastructure. Investigation of the stability of ON in the bag-type collectors used by CAPMoN is needed. Identification of a suitable preservative for daily and weekly precipitation samples is also a high priority. For PM measurements conducted under CASTNET and CAPMoN, the analytical method for total N developed for NTN (Walker et al., 2012) could be applied to provide weekly (CASTNET) and daily (CAPMoN) measurements of bulk water soluble ON in aerosols. Knowledge gaps and research needs associated with measurement and speciation of organic nitrogen are discussed in more detail in Section **3.1.2.5. Characterization of organic nitrogen in air and precipitation**.

Improvement of dry deposition algorithms in CTMs – Uncertainty in total deposition budgets is dominated by uncertainty in the dry deposition fraction. Improvements in parameterizations of non-stomatal exchange pathways are considered a high priority. Consideration of the influence of in- and near-canopy chemistry on net exchange fluxes is also needed, particularly for forests. Knowledge gaps and research priorities related to modeling of dry deposition are described in more detail in Sections **3.2.1. Application of a bidirectional ammonia air-surface exchange model at NADP AMoN sites**, **3.2.2. Development of in-canopy source/sink models that resolve deposition to ecosystem components (crown, understory, ground) and in-canopy chemistry**, and **3.2.3. Modeling fluxes of reactive nitrogen using chemical transport models**.

Improved treatment of ON in CTMs – Along with incorporation of ON measurements in national monitoring networks, a more detailed treatment of ON in CTMs is also a long-term goal with benefits for understanding not only deposition but also aerosol processes. Improvement of models will require advances in measurements to better understand the sources, atmospheric concentrations, exchange processes, of ON compounds. While organic nitrates have been the source of much recent research in the atmospheric chemistry community, research to better understand reduced forms of ON (e.g., amines) is considered a high priority. Knowledge gaps and research needs associated with measurement and modeling of ON are discussed in more detail in Sections **3.1.2.5. Characterization of organic nitrogen in air and precipitation** and **3.2.3. Modeling fluxes of reactive nitrogen using chemical transport models**.

Adoption of land-use specific deposition in MMF – Land use specific deposition velocities and fluxes are more useful to the critical loads community than grid-averaged values. Adoption of the MOSAIC type approach within a MMF framework to produce maps of land use specific total deposition could be explored.

Establishment of MMF bias correction procedure for NH₃ – NH₃ is an important contributor to the dry deposition budget yet the bidirectional nature of NH₃ air surface exchange makes bias correction of concentration fields for MMF applications difficult. Methods for bias correcting concentrations or fluxes derived from CTMs are needed.

Uncertainty maps for critical load assessments – An ultimate goal is to generate maps of uncertainty that could accompany maps of total deposition for critical loads assessments.

Opportunities for collaboration

Natural synergies and opportunities for enhanced coordination can be found by using and sharing common models and modeling inputs (emissions, meteorology) and through model development and evaluation. While many productive collaborations have been developed within the TDep community, additional opportunities exist. Comparison of deposition processes among models used for deposition assessments in North America (CMAQ, CAMx, GEM-MACH) will directly inform the development of uncertainty estimates for total deposition. Development of more modular codes and software architectures that allow for easier implementation and comparison of different parameterizations is needed. Such efforts could draw on modeling expertise within EPA, NPS, ECCO, and NOAA. The incorporation of satellite data (NOAA, NASA) within the hybrid TDep methodology (EPA) could also be explored. Greater collaboration among the critical loads and deposition scientists (i.e., TDep and CLAD) is also needed. Deposition scientists need to understand the form of uncertainty that will be most useful to critical load efforts. For instance, a more qualitative metric may be adequate for some deposition assessments. Conversely, it is up to the deposition scientists to inform the critical loads scientists of the limitations of deposition measurements and models.

References

Appel, K.W., Napelenok, S., Hogrefe, C., Pouliot, G., Foley, K.M., Roselle, S.J., Pleim, J.E., Bash, J., Pye, H.O.T., Heath, N., Murphy, B., Mathur, R., 2018. Overview and Evaluation of the Community Multiscale Air Quality (CMAQ) Modeling System Version 5.2, in: Mensink, C., Kallos, G. (Eds.), *Air Pollution Modeling and its Application XXV*. Springer International Publishing, Cham, pp. 69-73.

Ball, J.T., Woodrow, I.E., Berry, J.A. 1987. A model predicting stomatal conductance and its contribution to the control of photosynthesis under different environmental conditions. In *Progress in Photosynthesis Research*, edited, pp. 221-224, Springer.

Bash, J.O., Baker, K.R., Beaver, M.R. 2016. Evaluation of improved land use and canopy representation in BEIS v3.61 with biogenic VOC measurements in California. *Geoscientific Model Development*, 9, 2191-2207.

Bash, J.O., Walker, J.T., Schwede, D., Campbell, P., Spero, T., Appel, W., Shephard, M., Cady-Pereira, K., Pinder, R., Pye, H., Murphy, B., Fahey, K. 2018. Introducing the Surface Tiled Aerosol and Gaseous Exchange (STAGE) dry deposition option for CMAQ v5.3. 2018 Community Modeling and Analysis System (CMAS) Conference, October 22 – 24, 2018, Chapel Hill, NC.

Beem, K.B., et al. 2010. Deposition of reactive nitrogen during the Rocky Mountain Airborne Nitrogen and Sulfur (RoMANS) study. *Environmental Pollution*, 158, 862–872.

Bell, M.D., Phelan, J., Blett, T.F., Landers, D., Nahlik, A.M., Van Houtven, G., Davis, C., Clark, C.M., Hewitt, J. 2017. A framework to quantify the strength of ecological links between an environmental stressor and final ecosystem services. *Ecosphere*, 8, e01806.

Benedict, K.B., 2012. Observations of atmospheric reactive nitrogen species and nitrogen deposition in the Rocky Mountains. Dissertation, Colorado State University.
<https://dspace.library.colostate.edu/handle/10217/71545>

Bermejo-Orduna, R., McBride, J.R., Shiraishi, K., Elustondo, D., Lasheras, E., Santamaria, J.M. 2014. Biomonitoring of traffic-related nitrogen pollution using *Letharia vulpina* (L.) Hue in the Sierra Nevada, California. *Science of the Total Environment*, 290, 205–212.

Brook, J., Zhang, L., Franco, D., Padro, J. 1999. Description and evaluation of a model of deposition velocities for routine estimates of air pollutant dry deposition over North America, Part II: Review of past measurements and model results, *Atmospheric Environment*, 33, 5053–5070.

Calderón, S.M., Poor, N.D., Campbell, S.W. 2007. Estimation of the particle and gas scavenging contributions to wet deposition of organic nitrogen. *Atmospheric Environment*, 41, 4281–4290.

- Cape, J.N., Cornell, S.E., Jickells, T.D., Nemitz, E., 2011. Organic nitrogen in the atmosphere — Where does it come from? A review of sources and methods. *Atmospheric Research*, 102, 30–48.
- Carter, W.P.L., 2010. Development of the SAPRC-07 chemical mechanism. *Atmospheric Environment*, 44, 5324-5335.
- Chen, X., Xie, M., Hays, M.D., Edgerton, E., Schwede, D., Walker, J.T. 2018. Characterization of organic nitrogen in aerosols at a forest site in the southern Appalachian Mountains. *Atmospheric Chemistry and Physics*, 18, 6829-6846.
- Cheng, M., Jiang, H., Guo, Z., Zhang, X., Lu, X. 2013. Estimating NO₂ dry deposition using satellite data in eastern China. *International Journal of Remote Sensing*, 34, 2548–2565.
- Clark, C.M., Phelan, J., Doraiswamy, P., Buckley, J., Cajka, J.C., Dennis, R.L., Lynch, J., Nolte, C.G., Spero, T.L. 2018. Atmospheric deposition and exceedances of critical loads from 1800-2025 for the conterminous United States. *Ecological Applications*, 28, 978-1002.
- Dennis, R.L., Schwede, D.B., Bash, J.O., Pleim, J.E., Walker, J.T., Foley, K.M. 2013. Sensitivity of continental United States atmospheric budgets of oxidized and reduced nitrogen to dry deposition parameterizations. *Philosophical Transactions of the Royal Society B*, 368, 20130124.
- Dentener, F., Drevet, J., Lamarque, J.F., Bey, I., Eickhout, B., Fiore, A.M., et al. 2006. Nitrogen and sulfur deposition on regional and global scales: A multimodel evaluation. *Global Biogeochemical Cycles*, 20, GB4003.
- Famulari, D., Fowler, D., Nemitz, E., Hargreaves, K.J., Storeton-West, R.L., Rutherford, G., Tang, Y.S., Sutton, M.A., Weston, K.J. 2010. Development of a low-cost system for measuring conditional time-averaged gradients of SO₂ and NH₃. *Environmental Monitoring and Assessment*, 161, 11-27.
- Flechard, C., Nemitz, E., Smith, R., Fowler, D., Vermeulen, A., Bleeker, A., et al. 2011. Dry deposition of reactive nitrogen to European ecosystems: A comparison of inferential models across the NitroEurope network. *Atmospheric Chemistry and Physics*, 11, 2703–2728.
- Geiser, L. H., Jovan, S.E., Glavich, D.A., Porter, M.K. 2010. Lichen-based critical loads for atmospheric nitrogen deposition in Western Oregon and Washington Forests, USA. *Environmental Pollution*, 158, 2412-2421.
- Gilliam, R. C., Hogrefe, C., Godowitch, J.M., Napelenok, S., Mathur, R., Rao, S.T. 2015. Impact of inherent meteorology uncertainty on air quality model predictions. *Journal of Geophysical Research - Atmospheres*, 120, 12,259–12,280.
- Guenther, A.B., Jiang, X., Heald, C.L., Sakulyanontvittaya, T., Duhl, T., Emmons, L.K., Wang, X., 2012. The Model of Emissions of Gases and Aerosols from Nature version 2.1 (MEGAN2.1): an

extended and updated framework for modeling biogenic emissions. *Geoscientific Model Development*, 5, 1471-1492.

He, Z., Wright, L., Zhang, L. 2013. Model-measurement comparison of ammonia bi-directional air-surface exchange fluxes over agricultural fields. *Atmospheric and Climate Sciences*, 3, 465-474.

Jarvis, P. 1976. The interpretation of the variations in leaf water potential and stomatal conductance found in canopies in the field. *Philosophical Transactions of the Royal Society - B*, 273, 593-610.

Jickells, T., Baker, A.R., Cape, J.N., Cornell, S.E., Nemitz, E., 2013. The cycling of organic nitrogen through the atmosphere. *Philosophical Transactions of the Royal Society – B*, 368, 20130115.

Jovan, S. 2008. Lichen bioindication of biodiversity, air quality, and climate: Baseline Results from monitoring in Washington, Oregon, and California. General Technical Report PNW-GTR-737.

Keene, W.C., Montag, J.A., Maben, J.R., Southwell, M., Leonard, J., Church, T.M., Moody, J.L., Galloway, J.N. 2002. Organic nitrogen in precipitation over Eastern North America. *Atmospheric Environment*, 36, 4529–4540.

Lamarque, J.-F., Dentener, F., McConnell, J., Ro, C.-U., Shaw, M., Vet, R., Bergmann, D., Cameron-Smith, P., Dalsoren, S., Doherty, R., Faluvegi, G., Ghan, S.J., Josse, B., Lee, Y.H., Mackenzie, I.A., Plummer, D., Shindell, D.T., Skeie, R.B., Stevenson, D.S., Strode, S., Zeng, G., Curran, M., Dahl-Jensen, D., Das, S., Fritzsche, D., Nolan, M. 2013. Multi-model mean nitrogen and sulfur deposition from the atmospheric chemistry and climate model intercomparison project (ACCMIP): Evaluation of historical and projected future changes. *Atmospheric Chemistry and Physics*, 13, 7997-8018.

Lear, G.G. 2017, April. Quantifying a few uncertainties in TDep. Presented for TDep Maps Update at Spring 2017 NADP meeting, Louisville, KY.

Luecken, D.J., Yarwood, G., Hutzell, W.H. 2019. Multipollutant of ozone, reactive nitrogen and HAPs across the continental US with CMAQ-CB6. *Atmospheric Environment* 201, 62-72.

Li, Y., Schichtel, B., Walker, J.T., Schwede, D.B., Chen, X.I., Lehmann, C., Puchalski, M., Gay, D., Collett, J.L. Jr. 2016. The increasing importance of deposition of reduced nitrogen in the United States. *Proceedings of the National Academy of Sciences*, 113, 5874–5879.

Lin, M., Walker, J., Geron, C., Khlystov, A., 2010. Organic nitrogen in PM_{2.5} aerosol at a forest site in the Southeast US. *Atmospheric Chemistry and Physics* 10, 2145-2157.

Makar, P. A., Akingunola, A., Aherne, J., Cole, A. S., Aklilu, Y.- A., Zhang, J., Wong, I., Hayden, K., Li, S.-M., Kirk, J., Scott, K., Moran, M. D., Robichaud, A., Cathcart, H., Baratzedah, P., Pabla, B., Cheung, P., Zheng, Q., and Jeffries, D. S. 2018. Estimates of Exceedances of Critical Loads for

Acidifying Deposition in Alberta and Saskatchewan. *Atmospheric Chemistry and Physics*, 18, 9897-9927.

Massad, R-S., Nemitz, E., Sutton, M.A. 2010. Review and parameterisation of bi-directional ammonia exchange between vegetation and the atmosphere. *Atmospheric Chemistry and Physics*, 10, 10359-10386.

McMurray, J.A., Roberts, D.W., Geiser, L.H. 2015. Epiphytic lichen indication of nitrogen deposition and climate in the northern Rocky Mountains, USA. *Ecological Indicators*, 49, 154-161.

Meyers T.P., Finkelstein P., Clarke J., Ellestad, T.G., Sims, P.F. 1998. A multilayer model for inferring dry deposition using standard meteorological measurements. *Journal of Geophysical Research Atmospheres*, 103, 22645-22661.

Moran, M. D., Ménard, S., Talbot, D., Huang, P., Makar, P. A., Gong, W., Landry, H., Gravel, S., Gong, S., Crevier, L.-P., Kallaur, A., Sassi, M. 2010. Particulate-matter forecasting with GEM-MACH15, a new Canadian air-quality forecast model, in: *Air Pollution Modelling and its Application XX*, edited by Steyn, D. G. and Rao, S. T., pp. 289–292, Springer, Dordrecht.

Munger, J. W., Wofsy, S.C., Bakwin, P.S., Fan, S.M., Goulden, M.L., Daube, B.C., Goldstein, A.H., Moore, K.E., Fitzjarrald, D.R. 1996. Atmospheric deposition of reactive nitrogen oxides and ozone in a temperate deciduous forest and a subarctic woodland: 1. Measurements and mechanisms. *Journal of Geophysical Research - Atmospheres*, 101, 12639-12657.

Munns, W.R. Jr., Rea, A.W., Mazzotta, M.J., Wainger, L., Saterson, K. 2015. Toward a standard lexicon for ecosystem services. *Integrated Environmental Assessment and Management*, 11, 666-673.

Nilsson, J., Greenfelt, P., 1988. Critical levels for sulphur and nitrogen, 418 pp., Nordic Council of Minist., Copenhagen, Denmark.

Paulot, F., Malyshev, S., Nguyen, T., Crounse, J. D., Shevliakova, E., Horowitz, L. W. 2018. Representing sub-grid scale variations in nitrogen deposition associated with land use in a global Earth System Model: implications for present and future nitrogen deposition fluxes over North America. *Atmospheric Chemistry and Physics*, 18, 17963-17978.

Pleim, J.E., Bash, J.O., Walker, J.T., Cooter, E.J. 2013. Development and evaluation of an ammonia bi-directional flux parameterization for air quality models. *Journal of Geophysical Research-Atmospheres*, 118, 3794–3806.

Ran, L., Pleim, J., Gilliam, R., Binkowski, F.S., Hogrefe, C., Band, L. 2016. Improved meteorology from an updated WRF/CMAQ modeling system with MODIS vegetation and albedo. *Journal of Geophysical Research - Atmospheres*, 121, 2393–2415.

Russell, K.M., Keene, W.C., Maben, J.R., Galloway, J.N., Moody, J.L. 2003. Phase partitioning and dry deposition of atmospheric nitrogen at the mid- Atlantic US coast. *Journal of Geophysical Research – Atmospheres*, 108, 4656.

Root, H.T., Geiser, L.H., Fenn, M.E., Jovan, S., Hutten, M.A., Ahuja, S., Dillman, K., Schirokauer, D., Berryman, S., and McMurray, J.A. 2013. A simple tool for estimating throughfall nitrogen deposition in forests of western North America using lichens. *Forest Ecology and Management*, 306, 1-8.

Schwede, D., Zhang, L., Vet, R., Lear, G. 2011. An intercomparison of the deposition models used in the CASTNET and CAPMoN networks. *Atmospheric Environment*, 45, 1337-1346.

Schwede, D.B., Lear, G.G. 2014. A novel hybrid approach for estimating total deposition in the United States. *Atmospheric Environment*, 92, 207-220.

Schwede, D., Simpson, D., Tan, J., Fu, J., Dentener, F., Du, E., deVries, W. 2018. Spatial variation of modelled total, dry and wet nitrogen deposition to forest at global scale. *Environmental Pollution*, 243 Part B, 1287-1301.

Simpson, D., Benedictow, A., Berge, H., Bergström, R., Emberson, L.D., Fagerli, H., Flechard, C.R., Hayman, G.D., Gauss, M., Jonson, J.E., Jenkin, M.E., Nyíri, A., Richter, C., Semeena, V.S., Tsyro, S., Tuovinen, J.P., Valdebenito, Á., Wind, P., 2012. The EMEP MSC-W chemical transport model – technical description. *Atmospheric Chemistry and Physics*, 12, 7825-7865.

Scudlark, J.R., Russell, K.M., Galloway, J.N., Church, T.M., Keene, W.C. 1998. Dissolved organic nitrogen in precipitation at the mid-Atlantic US coast: methods evaluation and preliminary data. *Atmospheric Environment*, 32, 1719–1728.

Solazzo, E., R. Bianconi, G. Pirovano, V. Matthias, R. Vautard, M.D. Moran, K.W., et al. 2012. Operational model evaluation for particulate matter in Europe and North America in the context of AQMEII. *Atmospheric Environment*, 53, 75-92.

Swall, J.L., Foley, K.M. 2009. The impact of spatial correlation and incommensurability on model evaluation. *Atmospheric Environment*, 43, 1204-1217.

Tan, J., Fu, J.S., Dentener, F., Sun, J., Emmons, L., Tilmes, S., Sudo, K., Flemming, J., Jonson, J.E., Gravel, S., Bian, H., Davila, Y., Henze, D.K., Lund, M.T., Kucsera, T., Takemura, T., Keating, T. 2018. Multi-model study of HTAP II on sulfur and nitrogen deposition. *Atmospheric Chemistry and Physics*, 18, 6847-6866.

Vet, R., Artz, R.S., Carou, S., Shaw, M., Ro, C.-U., Aas, W., Baker, A., Bowersox, V.C., Dentener, F., Galy-Lacaux, C., Hou, A., Pienaar, J.J., Gillett, R., Forti, M.C., Gromov, S., Hara, H., Khodzher, T., Mahowald, N.M., Nickovic, S., Rao, P.S.P., Reid, N.W. 2014. A global assessment of precipitation chemistry and deposition of sulfur, nitrogen, sea salt, base cations, organic acids, acidity and pH, and phosphorus. *Atmospheric Environment*, 93, 3-100.

- Walker, J.T., Dombek, T.L., Green, L.A., Gartman, N., Lehmann, C.M.B. 2012. Stability of organic nitrogen in NADP wet deposition samples. *Atmospheric Environment*, 60, 573–582.
- Whitall, D.R., Paerl, H.W. 2001. Spatiotemporal variability of wet atmospheric nitrogen deposition to the Neuse River Estuary, North Carolina. *Journal of Environmental Quality*, 30, 1508–1515.
- Will-Wolf, S., Jovan, S., Amacher, M.C. 2017. Lichen elemental content bioindicators for air quality in upper Midwest, USA: A model for large-scale monitoring. *Ecological Indicators*, 78, 253-263.
- Williams, J.J., Chung, S.H., Johansen, A.M., Lamb, B.K., Vaughan, J.K., Beutel, M. 2017. Evaluation of atmospheric nitrogen deposition model performance in the context of U.S. critical load assessments. *Atmospheric Environment*, 150, 244-255.
- Wu, Z.Y., Wang, X., Turnipseed, A.A., Chen, F., Zhang, L., Guenther, A.B., et al. 2012. Evaluation and improvements of two community models in simulating dry deposition velocities for peroxyacetyl nitrate (PAN) over a coniferous forest. *Journal of Geophysical Research - Atmospheres*, 117, D04310.
- Wu, Z.Y., Schwede, D., Vet, R., Walker, J., Shaw, M., Staebler, R., Zhang, L. 2018. Evaluation and intercomparison of five North American dry deposition algorithms at a mixed forest site. *Journal of Advances in Modeling Earth Systems*, 10, 1571 – 1586.
- Yarwood, G., Jung, J., Whitten, G.Z., Heo, G., Mellberg, J., Estes, M., 2010. Updates to the Carbon Bond Mechanism for Version 6 (CB6). Presented at the 9th Annual CMAS Conference, Chapel Hill, NC, October 11-13, p. 2. Available online: http://www.cmascenter.org/conference/2010/abstracts/emery_updates_carbon_2010.pdf.
- Zamora, L.M., Prospero, J.M., Hansell, D.A. 2011. Organic nitrogen in aerosols and precipitation at Barbados and Miami: implications regarding sources, transport and deposition to the western subtropical Atlantic. *Journal of Geophysical Research – Atmospheres*, 116, D20309.
- Zhang, Q., Anatasio, C., Jimenez-Cruz, M. 2002. Water soluble organic nitrogen in atmospheric fine particles (PM_{2.5}) from northern California. *Journal of Geophysical Research – Atmospheres*, 107, AAC 3-1–AAC 3-9.
- Zhang, L., Wright, L.P., Asman, W.A.H. 2010. Bi-directional air-surface exchange of atmospheric ammonia: A review of measurements and a development of a big-leaf model for applications in regional-scale air-quality models. *Journal of Geophysical Research – Atmospheres*, 115, D20.
- Zhang, R., Thompson, T.M., Barna, M.G., Hand, J.L., McMurray, J.A., Bell, M.D., Malm, W.C., Schichtel, B.A. 2018. Source regions contributing to excess reactive nitrogen deposition in the Greater Yellowstone Area (GYA) of the United States. *Atmospheric Chemistry and Physics*, 18, 12991-13011. <https://doi.org/10.5194/acp-18-12991-2018>

3.3. Source Contributions to Total Nr Deposition

There is a need for researchers and environmental managers to understand the source contributions to the total Nr deposition budget. This will allow a better distinction of sources that can be mitigated via regulation, and characterize potential impacts of regulation leading to more effective policy. Section **3.3.1. Development and testing of source, receptor, and hybrid-oriented apportionment methods** provides some background into different approaches to source apportionment modeling and identifies key knowledge gaps in the field. Incorporation of recent scientific understanding into source apportionment modules is a high-priority as these modules can lag behind the sophistication of the CTMs that they often complement. One technique that has shown promise is the isotopic analysis of both air and water samples. This information can be coupled with databases of isotopic source-signature ratios to provide a new dynamic to apportionment techniques. Background information and knowledge gaps in this field are discussed in **3.3.2. Isotopic advances in understanding Nr deposition.**

3.3.1. Development and testing of source, receptor, and hybrid-oriented apportionment methods

Tammy Thompson¹, Gregory M. Beachley², Kristi Gebhart³

¹S&T Policy Fellow, American Association for the Advancement of Science, Hosted by U.S. EPA National Center for Environmental Economics, Washington, DC 20460

²U.S. EPA, Office of Air Programs, Washington, DC 20460

³U.S. National Park Service, Air Resources Division, Fort Collins, CO 80523

Research topic summary

When assessing the levels of Nr deposition to ecosystems, it is important to understand the origins of the Nr to facilitate the design of effective control strategies. Source apportionment modeling provides a quantitative estimate of the contributions of individual sources to total Nr deposition at an area of interest. The models used include receptor, source, and hybrid models, which range in complexity from equations with simple linear least squares solutions to adjoint modules run in conjunction with CTMs. The best-suited model is usually selected based on a researcher's objectives and available dataset, however, the simplest models are generally reserved for simplistic cases where there is little confounding information (i.e., an obvious source, minor degrees of atmospheric processing of pollutants). Source apportionment modeling relies on the accuracy of the base modeling performance, and therefore, the knowledge gaps in the source apportionment field are focused on the major scientific needs of the base models and, importantly, modernizing those models to reflect the evolving state of the science. However, areas where existing knowledge has not been sufficiently exploited in the source apportionment modules are presented. The key knowledge gaps are 1) to improve the base model performance through improvements in input data and process parameterizations; 2) the incorporation of the state of the science of chemical and physical atmospheric processes into source apportionment modules and 3) the development and improvement of methods to capture uncertainty associated with source apportionment modeling. All three of these gaps will require some degree of performance review and modeling development and would be met in the long-term.

Introduction

The goal of source apportionment modeling is to estimate the contributions of user-defined sources of atmospheric pollution to concentrations and/or total deposition measured at a

receptor location. Target receptor locations can include air quality monitoring stations, population centers, sensitive ecosystems, or any location of interest. Sources can be defined by location and/or by source sector and can range from a single point source to entire states or economic sectors. This source apportionment information is important when assessing where and what emissions reductions will be most effective to reduce concentrations or deposition in areas where reductions are needed. Because source/receptor relationships cannot be directly measured, models are required to estimate these relationships. The different modeling approaches used for source apportionment will be presented and discussed in this section. The two main modeling strategies are receptor models and source models. Models that use elements of both techniques are classified as hybrid models. Ultimately, the goals of source apportionment modeling in terms of the Nr budget are a better distinction of sources that can be mitigated via regulation and voluntary best management practices, and characterization of what the resulting impacts might be. This can lead researchers to understand what portion of Nr deposition can be controlled and potentially lead to useful strategic policy for maximum benefits.

Receptor models

Receptor modeling techniques use both meteorological and concentration observations made at a receptor location to infer source contributions. A typical model is expressed as:

$$C_{it} = \sum F_{ij} S_{jt} T_{it} \quad (1)$$

as summarized in Malm et al (1990) and Lowenthal et al (2010), where C_{it} is the concentration of the i^{th} chemical species measured at time t . C_{it} is the sum of the products of fractional contributions (F_{ij}) of the i^{th} species in the j^{th} source, the emission profile, or mass contribution (S_{jt}) of the j^{th} source at time t and the change in source contribution by removal or chemical transformation (T_{it}). The removal/transformation term was not included in all studies and the mean value is incorporated into the regression coefficient if not supplied. Some key advantages to using a receptor approach are the limited computational resources and data inputs required. These models can often be simplistic to run and can be run in combination with other methods to refine approaches and improve source apportionment estimates as done with hybrid modeling techniques. Solutions usually contain non-linearities (e.g. atmospheric transformations) unless the models are designed to account for them.

A key limitation is that the basic equation is under-determined and thus an infinite number of solutions are possible unless refined with added constraints. These constraints can be applied to many aspects of the model and examples include forcing solutions to be non-negative (e.g. Positive Matrix Factorization; PMF) (Paatero and Tapper, 1994), or using measured concentrations to constrain possible solutions based on emissions or source profiles (Watson et al., 1984; Paatero and Hopke, 2009; Amato and Hopke, 2012) or as limits on ranges of source composition stoichiometry (Henry, 2003).

Hybrid models

Hybrid modeling techniques use transport-forecasting algorithms based on locally observed meteorological data typically associated with source modeling techniques to limit the realm of possible solutions that equation (1) can resolve to. This can be as simplistic as limiting possible sources to downwind directions (Cooper et al., 1982; Yamartino, 1982; Park et al., 2005) or as complex as calculating air mass back trajectories to determine where air masses most commonly reside prior to episodic high concentration or deposition events at a receptor site (Prenni et al., 2014; Gebhart et al., 2011 & 2014).

While the addition of data-derived constraints to nudge solutions to more realistic scenarios is an improvement, there is the limitation that the output data is only as good as the accuracy of the data used, and that application of these constraints is based on the subjective criterion developed by the modeler (Lowenthal, 2010). Invalid assumptions based on errors such as invalid extrapolation of local measurements or variations in source emissions (both in strength and composition) can create inaccurate model output, therefore all steps in the modeling process must be carefully considered.

Source models

Source modeling techniques follow the emitted pollutant from emission, through transport, transformation and removal in the atmosphere to estimate source impacts at a receptor location. The most common examples of source models are CTMs. CTMs employ complex algorithms to predict the physical movement and chemical reactions of species based on large input data sets that define the key processes that drive atmospheric transport and transformation. The CTMs that are most widely used in the U.S. for research and in policy decision making include CMAQ (Byun and Schere, 2006; www.epa.gov/cmaq), CAMx (www.camx.com), and GEOS-Chem (Bey et al., 2001).

In most cases, source apportionment (SA) modules are built into the CTM code. An example of a basic SA method that can be used with any CTM without requiring internal code is the Brute Force Method (BFM). The BFM estimates the contributions of sources to any receptor by systematically removing possible emission sources from the input emissions inventory one by one and calculating differences in resulting modeled concentrations or deposition totals at receptors. Because BFM requires a unique model run for each individual emissions source group and source region of interest, it can be time intensive if multiple groups and regions are selected. However, a major benefit of BFM is that all air quality metrics (i.e., the impact to different species of pollutants) can be evaluated using a single run. Overall strengths of source modeling techniques and CTMs are that they incorporate detailed data on emissions, meteorology, atmospheric chemistry and physics to model the release, movement, chemical transformation, and removal of chemical species in the atmosphere. This allows modelers to estimate the interaction and influence of all sources and processes on modeled ambient concentrations or total deposition at receptor locations at any time during the modeling run.

Meaningful SA results from CTMs are dependent on an accurate representation of model inputs and processes. Any SA modeling should begin with a base model performance evaluation which compares modeled concentrations to measurements in order to demonstrate the ability of the model to capture temporal and spatial variability in concentrations. When model performance is good (i.e. meets criteria recommended by EPA guidance; U.S. EPA, 2007), it provides a measure of confidence that the inputs, including emissions, meteorology and chemistry, are reasonable representations of what is happening in the atmosphere. Model performance evaluations (MPE) typically estimate performance statistics on average across the modeling domain. In cases where these models may be used to make policy recommendations for a specific location, a more detailed MPE would focus specifically on the area of interest. CTM runs require a large degree of effort and computational power. These requirements make the estimation of uncertainty difficult. Additionally, because details associated with all areas and sectors are not always available, the datasets that are input are often extrapolated.

While there are many developments that have improved the accuracy of SA modeling, research is still needed to further develop this technique. Research needs can be broadly categorized into three groups: 1) Improving base model performance through improvements in input data and process parameterizations, 2) the incorporation of the state of the science of chemical and physical atmospheric processes into SA modules, and 3) the development and improvement of methods to capture uncertainty associated with SA modeling (See Section **3.2.4. Assessing uncertainty in total Nr deposition estimates for North American critical load applications**).

Many areas of the country experience Nr deposition at levels above what is considered “safe” for the particular ecosystem in that area (Pardo et al., 2011). Recent research suggests that the predominant Nr species contributing to this deposition load is shifting from oxidized to reduced Nr (Du et al., 2014; Li et al., 2016). The scientific and regulatory communities have an interest in better understanding the causes of this shift, and the sources of all forms of Nr deposition. SA modeling studies are a key method for identifying the contribution of different sources to Nr deposition in areas of interest.

Attributing sources of Nr that contribute to overall deposition has been a key focus in attempting to quantify and manage excessive Nr loads to Rocky Mountain National Park (Rodriguez et al., 2011; Gebhart et al., 2011; Thompson et al., 2015). In Northeastern Colorado, there are large CAFO that have been shown to contribute to Nr deposition episodes in the sensitive high-elevation park areas under specific meteorological conditions (e.g. upslope events) (Wolfe et al., 2003; Benedict et al., 2013). SA methods have played a large role in identifying and understanding those conditions (Gebhart et al., 2011). Meteorologists can predict when these upslope events are likely to occur and thus, the development of timely control strategies (Ndegwa et al., 2008) during these conditions could effectively mitigate Nr transport and deposition into the park. Large-scale atmospheric measurement campaigns,

where large amounts of atmospheric data are collected with fine temporal and spatial resolution, are particularly useful in model development and evaluation to improve confidence in SA results (Malek et al., 2006; Ying et al., 2009; Prenni et al., 2014; Rodriguez et al., 2011; Gebhart et al., 2011; Thompson et al., 2015).

State of the science

Improving base model performance

To get meaningful SA results from modeling applications, the base model predictions need to accurately reflect real world measurements. Key features driving model performance are accuracy of input data, including emissions inventories and meteorological datasets, and accuracy of parameterizations designed to represent key chemical and physical processes in the model. In all of these cases, more measurements of both species concentration and meteorological metrics, with finer temporal and spatial resolution, will help drive model development activities and likely lead to improvements in model performance. The need for improved input data is equally applicable to receptor models, hybrid models, and source models as covered in the introduction.

Emissions inventories

One of the most pressing research needs for the improvement of SA modeling is a better understanding of the emissions inventories (see also Sections **3.2.3. Modeling fluxes of Nr using chemical transport models**; **3.4.1. Relationship of long-term Nr trends in emission and deposition**; **3.4.2. Spatial variability of ammonia in agricultural regions**). The location, timing and amount of the emissions of many species of Nr are uncertain. In addition to this, an improved understanding of the bi-directionality of the air-surface exchange of NH₃ is also needed (Wentworth et al., 2016; Dennis et al., 2010; see also Section **3.2.1. Application of a bidirectional ammonia air-surface exchange model at NADP AMoN sites**). Henze et al. (2009), using a version of the global scale model GEOS-Chem, identified regional scale emissions errors. By effectively tracing the measurements back in time to areas of emissions sources, they found that NH₃ emissions were under-estimated in some areas (Eastern U.S.), while others were over-estimated during some parts of the year (the mid-west in July). Over-estimations in some areas could be due to issues related to bi-directional flux. If the compensation point of the atmospheric NH₃ concentration is reached (the compensation point is the atmospheric concentration at which emissions from the soil are suppressed and deposition starts to occur) then emissions from the soil are not likely to occur despite default assumptions in the inventory (Bash et al., 2013). The compensation point, and thus the emissions and deposition rates at any time, depend on many factors including meteorological conditions, land cover, and soil conditions (Bash et al., 2013).

Meteorological input data

Accurate meteorological data are needed to drive many of the physical and chemical processes in the models that define the linkages between sources and receptors. The WRF model is most commonly used to develop input data for CTMs for regulatory modeling. WRF is a numerical weather prediction model that has the option to use output from weather datasets from coarser scale models as well as observations to nudge the model towards reality (Skamarock et al., 2008). WRF ultimately develops gridded meteorological input data at the resolution of the CTM run (often 12km or 4km grid resolution). The data fields that are used by CTMs and developed by WRF include: temperature, pressure, wind speed, wind direction, precipitation, relative humidity, vertical diffusivity, and cloud data.

Accurate representation of rain (location and amount) in meteorological models is particularly challenging, but extremely important if modeling wet deposition. Improvement in the representation/parameterization of rain in meteorological models is necessary. Measured rain data can often be used in place of modeled data, however this can create inconsistencies in the meteorological patterns that contribute to high deposition rates if measured data are applied to modeled concentrations without making sure that other processes (i.e., wind direction) are represented accurately. While meteorological models do very well in some locations, they can be inaccurate in complex terrain which may be influential on the source apportionment estimates. Areas with complex terrain (e.g. alpine environments) are often times areas where SA evaluation is needed.

Trajectory modeling approaches typically use the Hybrid Single-Particle Lagrangian Integrated Trajectory model (HYSPLIT; www.arl.gov/HYSPLIT_info.php, accessed October 9, 2018). HYSPLIT itself is not a meteorological model, but it uses output from other meteorological models to estimate the trajectory path of an air parcel (Draxler and Hess, 1998; Stein et al. 2015). HYSPLIT has the flexibility to use gridded output from several meteorological models to drive calculations, including WRF, and data resolution depends on the dataset. These data can be used to develop physical transport relationships between source and receptor locations. Increased confidence in the meteorological modeling data used as input to HYSPLIT can increase confidence in these estimated source/receptor relationships. In addition to transport, HYSPLIT can estimate dispersion directly or it can be estimated using ensemble mode which starts trajectories from neighboring grid cells and layers, Dispersion is important in the apportionment process to account for reduction in potential source strengths (e.g., Potempski et al. 2008; Lee et al. 2009; Solazzo et al. 2013; Stein et al. 2015). The plume dispersion factor can consider chemistry of the pollutant, particularly transformations, deposition, and emission processes. The benefit to a model like HYSPLIT over a full CTM, is that HYSPLIT can be run much faster. CTMs however incorporate more of the sources and the physical and chemical processes that may impact those relationships.

Chemical and physical processes

More generally, meteorological conditions will impact the chemical and physical processing of pollutants (e.g. temperature often drives reaction rate). For example, HNO₃ has a very high

deposition velocity, but once converted to NO_3^- in aerosol form, the particle can be transported over long distances. NH_4NO_3 particles are small, more volatile and subject to atmospheric processing, whereas NO_3^- particles associated with a base cation such as Na or Ca are larger and deposit more rapidly. Similar issues exist with limitations of models capturing the bidirectional exchange of NH_3 (see Section **3.2.1. Application of a bidirectional ammonia air-surface exchange model at NADP AMoN sites**). A more mature knowledge and improved model representation of the many processes that drive the lifetimes of Nr species in the atmosphere would help to evaluate the reasonableness of modeled source attributions.

Update and maintain SA modules

SA modeling relies on advancements in general modeling capabilities, but also on incorporating those advancements into the SA modules in CTMs. This section will highlight the SA capabilities and differences of the three CTMs that are predominantly used for public policy analysis in the U.S. and how those differences may impact the results obtained by each model. CMAQ and CAMx are regional CTMs, while GEOS-Chem is a global scale model. There is a need to update and maintain these models such that they incorporate the current scientific understanding of inputs and atmospheric processes.

There are several SA modules within the CAMx and CMAQ modeling frameworks that are designed to facilitate the estimation of source contributions: the tagged species source apportionment method (TSSA – CMAQ), the integrated source apportionment method (ISAM – CMAQ), the ozone source apportionment tool (OSAT-CAMx), the particulate source apportionment tool (PSAT – CAMx), and the direct decoupled method (DDM – both models). While BFM (described earlier) is done by manipulating the inputs to CTMs, these SA modules are incorporated directly into the CTM code using reactive tracer species mechanisms (Ramboll Environ, 2016). The SA modules generally monitor and track the transport and chemistry of the emissions of interest and output their contributions to primary and (in some cases) secondary pollutants at any stage and any location during the model run.

The TSSA method in CMAQ is the most straight-forward SA module. It tracks emissions of interest through physical processes in the atmosphere. TSSA does not account for full chemistry in the model, instead making the simplifying assumption that chemistry is linear between emissions species and their corresponding secondary pollutant species. For example, SO_2 is tracked directly to sulfate SO_4^{2-} under the assumption that the chemistry is linear. As an update to the TSSA method of source tracking in CMAQ, the ISAM was released with CMAQ v5.0.2. ISAM can be used to capture full chemistry in SA relationships and is comparable to PSAT in CAMx. Both the ISAM and PSAT modules estimate source contributions through a source tracer approach. Source groups are each assigned a unique tracer that follows along with the emissions of interest and acts as an observing species, with all the same chemical and physical characteristics. These tracer species effectively trace the movement and transformation of the original emissions of interest. Location and contribution to any secondary species can thus be identified.

The DDM estimates the first order sensitivity coefficients relating model output concentrations to small changes in input emissions. These coefficients are calculated internally within the modeling framework, and multiple sensitivity coefficients, each relating different sources to changes in concentrations, can be calculated within a single run of the model. The DDM can estimate sensitivities to different source regions, source groups, and pollutant species individually.

Incorporate uncertainty estimation

There is a great deal of discussion about the incorporation of uncertainty assessment into regional scale modeling as covered in Section **3.2.4. Assessing uncertainty in total Nr deposition estimates for North American critical load applications**. Here we briefly mention the need to, as more robust methods for uncertainty calculations are developed for modeling the various aspects of the N cycle, extend these new methods and procedures into SA modeling. A measure of the uncertainty associated with SA modeling will help the regulatory community weigh decisions about where and when to make cuts to emissions that lead to potentially damaging deposition.

Uncertainty evaluation approaches have been developed and tested for PMF receptor source apportionment models for PM (Lee and Russell, 2007; Shi et al., 2016). These approaches have not been extended to evaluate Nr deposition to our knowledge.

Future research

Significant knowledge gaps exist in SA modeling methods. These have been categorized broadly into 1) improvements in the understanding and model representation of the physical and chemical processes that impact the performance of the base model with respect to its representation of the deposition of Nr; 2) the incorporation of modeling advancements into SA modules; and 3) the development of methods to estimate uncertainty associated with SA of Nr species.

Emissions inventories for Nr need to be improved and expanded, especially for reduced Nr from agricultural operations. This includes more detail on the seasonality and timing of emissions and some more specificity of emissions by facility type, especially for animal husbandry. Reduced emissions uncertainty would help to improve overall SA model performance and aid our understanding of transport mechanisms and thus is a high priority. This knowledge gap could be advanced with two approaches: more exhaustive source cataloging of speciated Nr emissions (e.g. reducing the number of omitted sources included in the inventory), and the expansion of existing source information to include time-resolved emissions (e.g. seasonal, diurnal, or even hourly patterns). The former could be feasibly met in the near term, but the latter is likely a long-term effort as source-specific intensive measurements (preferably to characterize emissions and down-wind deposition) would be needed to categorize source-

types. The second approach would also meet knowledge gaps in Section **3.4.2. Spatial variability of ammonia in agricultural regions** for reduced Nr.

There also exists a large knowledge gap in the modeled representation of meteorological fields. This includes an accurate representation of rain (location and amount) which is extremely important for wet deposition, improved representation of meteorology in complex terrain, improved performance of meteorological predictions on smaller spatial scales. While these objectives are high priorities and would greatly reduce uncertainties in SA models (and the overall CTMs), they represent needed improvements to the overall CTMs and thus are considered a long-term research need. In terms of a more near-term research need, it would be helpful to establish understanding of the limitations of meteorological models and the impact that related uncertainties have on local SA results.

Parameterization of new knowledge from intensive studies into both CTM and SA modules is needed. CTM parameters are constantly revised and improved, and SA modules can lag behind the CTM in terms of advancements. A knowledge gap is to update the SA modules with the scientific understanding that is already available and/or incorporated in the CTMs and this could be met in the near-term. New knowledge that has not been parameterized into CTMs will be a longer-term research goal. These parameters could include new information on chemical reactions and rates and sensitivities to meteorological drivers. Parameters that have a limited base of monitoring data and are poorly understood will be long-term efforts. A particular example of this relevant to Nr is the incorporation of data on soil conditions. The limitations in modeling the bidirectional NH₃ fluxes is frequently identified as a knowledge gap and discussed in detail in Section **3.2.1. Application of a bidirectional ammonia air-surface exchange model at NADP AMoN sites.**

Updating SA modules

A measure of the uncertainty associated with SA modeling will help the regulatory community weigh decisions about where and when to make cuts to emissions that lead to potentially damaging deposition. As more robust methods for uncertainty calculations are developed for modeling the various aspects of the N cycle, efforts are needed to extend these new methods and procedures first into CTMs, and subsequently into SA modules. There are existing projects to estimate uncertainties in trajectory models, including varying the off-set from the original location by a single grid cell in each horizontal direction, and several hundred meters in the vertical, to estimate model uncertainty (Draxler, 2003). Recent work underway by NOAA's Air Resources Laboratory is looking at thousands of HYSPLIT plume dispersion simulations coupling stack emissions data measured by the EPA's Clean Air Markets Division and both hourly and weekly ambient monitoring data measured by EPA's NCore and CASTNET programs to determine the uncertainty in components of the pollution dispersion algorithms. Additional studies on characterization of model uncertainty would be helpful to increase confidence in source/receptor relationships.

Incorporation of uncertainty measures into SA modeling represents more of a long-term objective. Accurate uncertainty estimations rely on accurate source apportionment modeling and so improvements to base model performance, and incorporation of the state of the science into source apportionment modules are the priority objectives.

References

Amato, F., Hopke, P.K. 2012. Source apportionment of the ambient PM_{2.5} across St. Louis using constrained positive matrix factorization, *Atmospheric Environment* 46, 329-337.

Bash, J.O., Cooter, E.J., Dennis, R.L., Walker, J.T., Pleim, J.E., 2013. Evaluation of a regional air-quality model with bidirectional NH₃ exchange coupled to an agroecosystem model. *Biogeosciences* 10, 1635–1645. doi:10.5194/bg-10-1635-2013

Benedict, K.B., Day, D., Schwandner, F.M., Kreidenweis, S.M., Schichtel, B., Malm, W.C., Collett, J.L. 2013. Observations of atmospheric reactive nitrogen species in Rocky Mountain National Park and across northern Colorado. *Atmos. Environ.* 64, 66-76.
<https://doi.org/10.1016/j.atmosenv.2012.08.066>

Bey, I., Jacob, D.J., Yantosca, R.M., Logan, J.A., Field, B.D., Fiore, A.M., Li, Q., Liu, H.Y., Mickley, L.J., Schultz, M.G., 2001. Global modeling of tropospheric chemistry with assimilated meteorology: Model description and evaluation. *Journal of Geophysical Research: Atmospheres* 106, 23073–23095. doi:10.1029/2001JD000807

Byun, D., Schere, K.L., 2006. Review of the governing equations, computational algorithms, and other components of the Models-3 Community Multiscale Air Quality (CMAQ) modeling system. *Applied Mechanics Reviews* 59, 51-77.

Cooper, D.W. 1982. Receptor-oriented source–receptor analysis. Specialty Conference on Receptor Models Applied to Contemporary Pollution Problem. Danvers (MA). Acton (MA): Northeast Atl Int Sect of the Air Pollut Control Assoc.

Dennis, R.L., Mathur, R., Pleim, J.E. Walker, J.T., 2010. Fate of ammonia emissions at the local to regional scale as simulated by the Community Multiscale Air Quality model. *Atmospheric Pollution Research*, 1(4), 207-214.

Draxler, R.R., Hess, G.D., 1998. An overview of the HYSPLIT_4 modelling system for trajectories. *Australian meteorological magazine*, 47(4), 295-308.

Draxler, R.R., 2003. Evaluation of an Ensemble Dispersion Calculation. *Journal of Applied Meteorology* 42, 308-317.

Du, E., de Vries W., Galloway, J., Hu, X., Fang, J., 2014. Changes in wet nitrogen deposition in the United States between 1985 and 2012. *Environmental Research Letters* 9 (9), 095004.

- Gebhart, K.A., Malm, W.C., Rodriguez, M.A., Barna, M.G., Schichtel, B.A., Benedict, K.B., Collett, J.L., Carrico, C.M. 2014. Meteorological and Back Trajectory Modeling for the Rocky Mountain Atmospheric Nitrogen and Sulfur Study II. *Advances in Meteorology*, 2014, 414015. <http://dx.doi.org/10.1155/2014/414015>
- Gebhart, K.A., Schichtel B.A., Malm W.C., Barna M.G., Rodriguez, M.A., Collett, J.L. 2011. Back-trajectory-based source apportionment of airborne sulfur and nitrogen concentrations at Rocky Mountain National Park, Colorado, USA, *Atmospheric Environment*, 2011, 45 (3), 621-633.
- Henry, R.C., 2003. Multivariate receptor modeling by N-dimensional edge detection. *Chemometrics and intelligent laboratory systems*, 65(2), 179-189.
- Henze, D.K., Seinfeld, J.H., Shindell, D.T. 2009. Inverse modeling and mapping US air quality influences of inorganic PM_{2.5} precursor emissions using the adjoint of GEOS-Chem ISSN: 1680-7316, 1680-7324, *Atmos. Chem. Phys.*, 9 (16), 5877-5903.
- Lee, S., Russell, A.G., 2007. Estimating uncertainties and uncertainty contributors of CMB PM_{2.5} source apportionment results. *Atmospheric Environment* 41, 9616–9624. <https://doi.org/10.1016/j.atmosenv.2007.08.022>
- Lee, J. A., Peltier, L.J., Haupt, S.E., Wyngaard, J.C., Stauffer, D.R., Deng, A. 2009. Improving SCIPUFF dispersion forecasts with NWP ensembles. *J. Appl. Meteor. Climatol.*, 48, 2305–2319. doi:10.1175/2009JAMC2171.1.
- Li, Y., Schichtel, B.A., Walker, J.T., Schwede, D.B., Chen, X., Lehmann, C.M.B., Puchalski, M.A., Gay, D.A., Collett, J.L. 2016. Increasing importance of deposition of reduces nitrogen in the United States. *Proceedings of the National Academy of Sciences of the United States of America* 113, 5874-5879.
- Li, Y., Thompson, T.M., Van Damme, M., Chen, X., Benedict, K.B., Shao, Y., Day, D., Boris, A., Sullivan, A.P., Ham, J., Whitburn, S., Clarisse, L., Coheur, P.-F., Collett, J.L. 2017. Temporal and spatial variability of ammonia in urban and agricultural regions of northern Colorado, United States. *Atmos. Chem. and Phys.* 17, 6197–6213. doi:10.5194/acp-17-6197-2017
- Lowenthal D.H., Watson, J.G., Koracin, D., Chen, L.W.A., Dubois, D., Vellore, R., Kumar, N., Knipping, E.M., Wheeler, N., Craig, K., Reid, S. 2010. Evaluation of Regional-Scale Receptor Modeling. *JAWMA*, 60, 26-42. DOI: 10.3155/1047-3289.60.1.26
- Malek, E., David, T., Martin, R.S., Silva, P.J. 2006. Meteorological and environmental aspects of one of the worst national air pollution episodes (January, 2004) in Logan, Cache Valley, Utah, USA. *Atmospheric Research* 79, 108-122.
- Malm, W.C., Iyer, H.K., Watson, J., Latimer, D.A. 1990. A Variety of Receptor Modeling Techniques, *Transactions of the AWMA/EPA International Specialty Conference – Visibility and Fine Particles*, C.V. Mathai, Ed., 1, 781-805.

- Malm, W.C., Rodriguez, M.A., Schichtel, B.A., Gebhart, K.A., Thompson, T.M., Barna, M.G., Benedict, K. B., Carico, C.M., Collett J.L. 2016. A hybrid modeling approach for estimating reactive nitrogen deposition in Rocky Mountain National Park. *Atmos. Environ.* 126, 258-273.
- Ndegwa, P.M., Hristov, A.N., Arogo, J., Sheffield, R.E. 2008. A review of ammonia emission mitigation techniques for concentrated animal feeding operations. *Biosys. Eng.* 100, 453-469. doi:10.1016/j.biosystemseng.2008.05.010
- Paatero, P., Tapper, U., 1994. Positive matrix factorization: A non-negative factor model with optimal utilization of error estimates of data values. *Environmetrics* 5, 111–126. doi:10.1002/env.3170050203
- Paatero, P. Hopke, P.K., 2009. Rotational tools for factor analytic models. *Chemometrics* 23, 91-100.
- Pardo, L.H., Fenn, M.E., Goodale, C.L., Geiser, L.H., Driscoll, C.T., Allen, E.B., Baron, J.S., Bobbink, R., Bowman, W.D., Clark, C.M., Emmett, B., Gilliam, F.S., Greaver, T.L., Hall, S.J., Lilleskov, E.A., Liu, L., Lynch, J.A., Nadelhoffer, K.J., Perakis, S.S., Robin-Abbott, M.J., Stoddard, J.L., Weathers, K.C., Dennis, R.L., 2011. Effects of nitrogen deposition and empirical nitrogen critical loads for ecoregions of the United States. *Ecological Applications* 21, 3049–3082. doi:10.1890/10-2341.1
- Park, S.S., Pancras, J.P., Ondov, J.M., Poor, N. 2005. A new pseudo-deterministic multivariate receptor model for accurate individual source apportionment using highly resolved ambient concentration measurements. *J. Geophys. Res.* 110, D07S15.
- Potempski, S., Galmarini, S., Addis, R., Astrup, P., Bader, S., Bellasio, R., Bianconi, R., Bonnardot, F., Buckley, R., D'Amours, R., van Dijk, A., Geertsema, G., Jones, A., Kaufmann, P., Pechinger, U., Persson, C., Polreich, E., Prodanova, M., Robertson, L., Sørensen, J., Syrako, D. 2008. Multi-model ensemble analysis of the ETEX-2 experiment. *Atmos. Environ.* 42 (31), 7250-7265. <http://dx.doi.org/10.1016/j.atmosenv.2008.07.027>
- Prenni, A.J., Levin, E.J.T., Benedict, K.B., Sullivan, A.P., Schurman, M.I., Gebhart, K.A., Day, D.E., Carrico, C.M., Malm, W.C., Schichtel, B.A., Collett Jr., J.L., Kreidenweis, S.M. 2014. Gas-phase reactive nitrogen near Grand Teton National Park: Impacts of transport, anthropogenic emissions, and biomass burning. *Atmos. Environ.* 89, 749-756.
- Ramboll Environ, 2016. User's Guide, Comprehensive Air Quality Model with Extensions (CAMx) v 6.40. Available at: <http://www.camx.com>.
- Rodriguez, M.A., Barna, M.G., Gebhart, K.A., Hand, J.L., Adelman, Z.E., Schichtel, B.A., Collet, J.L. 2011. Modeling the fate of atmospheric reduced nitrogen during the Rocky Mountain Atmospheric Nitrogen and Sulfur Study (RoMANS): Performance evaluation and diagnosis using integrated processes rate analysis. *Atmos. Environ.* 45 (1), 223-234.
- Skamarock, W., Klemp, J., Dudhia, J., Gill, D., Barker, D., Wang, W., Huang, X.-Y., Duda, M., 2008. A Description of the Advanced Research WRF Version 3. UCAR/NCAR. doi:10.5065/D68S4MVH

- Shi, G.-L., Chen, H., Tian, Y.-Z., Song, D.-L., Zhou, L.-D., Chen, F., Yu, H.-F., Feng, Y.-C., 2016. Effect of Uncertainty on Source Contributions from the Positive Matrix Factorization Model for a Source Apportionment Study. *Aerosol and Air Quality Research* 16, 1665–1674. <https://doi.org/10.4209/aaqr.2015.12.0678>
- Solazzo, E., Riccio, A., Kioutsioukis, I., Galmarini, S. 2013. Pauci ex tanto numero: Reduce redundancy in multi-model ensembles. *Atmos. Chem. Phys.* 13, 8315–8333. doi:10.5194/acp-13-8315-2013.
- Stein, A.F., Draxler, R.R., Rolph, G.D., Stunder, B.J.B., Cohen, M.D., Ngan, F. 2015. NOAA’s HYSPLIT atmospheric transport and dispersion modeling system. *Bull. Amer. Meteor. Soc.*, 96, 2059–2077. <https://doi.org/10.1175/BAMS-D-14-00110.1>
- Thompson, T. M., Rodriguez, M.A., Barna, M.G., Gebhart, K.A., Hand, J.L., Day, D.E., Malm, W.C., Benedict, K.B., Collett Jr., J.L., Schichtel, B.S. 2015. Rocky Mountain National Park reduced nitrogen source apportionment, *J. Geophys. Res. Atmos.* 120, 4370–4384, doi:10.1002/2014JD022675
- Watson, J.G., Cooper, J.A., Huntzicker, J.J., 1984. The effective variance weighting for least squares calculations applied to the mass balance receptor model. *Atmospheric Environment* (1967) 18 (7), 1347–1355. [https://doi.org/10.1016/0004-6981\(84\)90043-X](https://doi.org/10.1016/0004-6981(84)90043-X)
- Wentworth, G.R., Murphy, J.G., Benedict, K.B., Bangs, E.J., Collett Jr., J.L., 2016. The role of dew as a night-time reservoir and morning source for atmospheric ammonia. *Atmos. Chem. Phys.* 16, 7435–7449. doi:10.5194/acp-16-7435-2016
- Wolfe, A.P., Van Gorp, A.C., Baron, J.S. 2003. Recent ecological and biogeochemical changes in alpine lakes of Rocky Mountain National Park (Colorado, USA): a response to anthropogenic nitrogen deposition. *Geobiology* 1, 153-168. <https://doi.org/10.1046/j.1472-4669.2003.00012.x>
- U.S. Environmental Protection Agency, 2007. Draft: Modeling Guidance for Demonstration Attainment of Air Quality Goals for Ozone, PM_{2.5}, and Regional Haze. Available at: https://www3.epa.gov/scram001/guidance/guide/draft_final-pm-O3-RH.pdf. Accessed April 2019.
- Yamartino, R.J. 1982. Formulation and application of a hybrid receptor model. Specialty Conference on Receptor Models Applied to Contemporary Pollution Problem. Danvers (MA). Acton (MA): Northeast Atl Int Sect of the Air Pollut Control Assoc.
- Ying, Q., Lu, J., Kleeman, M. 2009. Modeling air quality during the California Regional PM₁₀/PM_{2.5} Air Quality Study (CPRAQS) using the UCD/CIT source-oriented air quality model - Part III. Regional source apportionment of secondary and total airborne particulate matter. *Atmos. Environ.* 43, 419–430. doi:10.1016/j.atmosenv.2008.08.033
- Ying, Q., Kleeman, M. 2009. Regional contributions to airborne particulate matter in central California during a severe pollution episode. *Atmospheric Environment* 43, 1218-1228.

3.3.2. Isotopic advances in understanding Nr deposition

Emily M. Elliott¹, Zhongjie Yu¹, Amanda S. Cole², Justin G. Coughlin³

¹Department of Geology & Environmental Science, University of Pittsburgh, Pittsburgh, PA

²Environment and Climate Change Canada, Air Quality Research Division, Toronto, ON

³U.S. Environmental Protection Agency, Region 5, Chicago, IL

Research topic summary

Significant advances in the past decade have been made on research of atmospheric isotopes of Nr, but further research is required to more fully apply isotopes to understanding atmospheric Nr chemistry and deposition. While existing studies demonstrate that isotopic ratios of atmospheric Nr have great promise to aid in SA, the field needs further refinement before incorporation into regulatory contexts or frameworks.

Much of the needed future research will be focused on the characterization of isotopic Nr signatures from emission sources. This includes a more robust inventory of emission source signatures for NO_x and NH₃ emission sources and secondly, observations that focus on mechanisms driving variations in source signatures are extremely limited. We consider these research needs to be high priority that could be met in the short-term.

Further empirical experimental and field research is needed to characterize isotope effects (i.e., fractionations) that can occur during atmosphere chemical processing that can alter the fidelity of isotopic source signatures and the composition of Nr. Both laboratory and field studies are needed to address the effects of field conditions, geographic scale, and atmospheric processes on resulting isotopic compositions. Gradient studies, microscale to national-scale, employing Nr sampling, back trajectory analyses, mixing models, fractionation factors, are also needed. We also consider this overall research need to be a high priority that could be met in the short-term.

Another key need for research is the application of $\Delta^{17}\text{O}-\text{NO}_3^-$, a robust tracer of photochemical NO₃⁻ production in the atmosphere to understand the impact of atmospheric NO₃⁻ deposition on ecosystems, including streams and rivers. Expansion of this approach would help refine our general understanding of Nr dynamics in watersheds and ecosystems. We consider this future research to be a medium priority that can be met in the short-term.

Additionally, the incorporation of Nr isotope chemistry into CTMs (e.g., CMAQ, GEOS-CHEM) would allow for more detailed analysis of Nr chemistry and deposition processes, validation of emissions, and source tracking. This would further the understanding of atmospheric Nr

compound reactions and their resulting influence in the environment. We consider this overall research need to be a medium priority that could be met in the mid-term.

Lastly, the aforementioned future research would benefit from a clearer recognition of the importance of atmospheric deposition within the field of “atmospheric chemistry”. While atmospheric deposition clearly plays a role in individual disciplines (e.g., Ecosystem Studies, Hydrological Sciences, Atmospheric Chemistry, etc.), research involving atmospheric deposition is not clearly identified in categories outlined through federal funding organizations. Resolving potential funding venues for atmospheric deposition research is an immediate need and one that could be addressed in the short-term through conversations and collaborations between academic researchers and scientists at federal and state agencies.

Introduction

The abundance of stable isotopes in a chemical species depends not only on the natural abundance of isotopes available, but also on the chemical and physical processes that created that species. Therefore, measuring isotopic ratios can yield invaluable information regarding the sources and (bio)geochemical cycling of the species beyond what concentration measurements alone can provide. A classic example is the measurement of O and H isotope ratios in glacial ice, which are correlated with local temperatures, to reconstruct temperatures over millennia (e.g. Petit et al. 1999). Methodological advances have facilitated the unprecedented examination of the isotopic composition of Nr species in the atmosphere including NH₃, NO_x, and atmospheric NO₃⁻ (i.e., gaseous HNO₃ and aqueous HNO₃ and NO₃⁻). This isotopic information can provide new insight into mechanisms of transformation and cycling of N_r in the atmosphere and moreover help resolve the contribution of multiple NO_x and NH₃ emission sources to deposition across landscapes, regions, and continents.

Given that isotopic differences between atmospheric N- and O-bearing compounds are minute, the isotopic composition is reported relative to an international standard and expressed as the deviation, in parts per thousand (‰), from that standard:

$$\delta (\text{‰}) = (R_{\text{sample}}/R_{\text{standard}} - 1) \times 1000 \quad (1)$$

where R is the ratio of heavy-to-light isotope (e.g., ¹⁵N/¹⁴N), R_{sample} is that ratio in a sample, and R_{standard} is that ratio in the international standard. The international standard for N is atmospheric N₂ (¹⁵N/¹⁴N=0.0036782 (De Bièvre et al., 1996)). O has three stable isotopes (¹⁶O, ¹⁷O, ¹⁸O), and isotopic analysis of O isotope ratios (¹⁷O/¹⁶O and ¹⁸O/¹⁶O) is placed on the scale of Vienna Standard Mean Ocean Water (VSMOW) scale (¹⁷O/¹⁶O=0.0003799, ¹⁸O/¹⁶O=0.0020052 (Li et al., 1988; Baertschi, 1976)).

Importantly, the mass differences between isotopically substituted N- and O-bearing compounds impact their partitioning rates between chemical species and phases, resulting in subtle, albeit measurable, changes in the heavy-to-light isotope rates (e.g., ¹⁵N/¹⁴N, ¹⁷O/¹⁶O and

$^{18}\text{O}/^{16}\text{O}$), known as isotopic fractionation. The degree of isotopic fractionation in kinetic processes can be quantified by a kinetic fractionation factor (α_k), which is defined by the instantaneous change in the isotope ratio of the reaction product (R_p) at a given substrate isotope ratio (R_s): $\alpha_k=R_s/R_p$. As molecules containing heavier isotopes usually react more slowly than those containing lighter isotopes, a normal kinetic fractionation will enrich heavier isotopes in the reaction substrate than in the reaction product, resulting in a $\alpha_k<1$. In reversible equilibrium reactions, isotope ratios of two species, A and B, at equilibrium can be related by an equilibrium fractionation factor, $\alpha_{eq}=R_B/R_A$. By convention, isotopic fractionation can also be expressed in units of ‰ as isotope effect (ϵ): $\epsilon=(\alpha-1)\times 1000$.

While the vast majority of the isotope effects observed in nature, whether equilibrium or kinetic, depend in some way upon mass differences between the different isotopes (Kaye 1987), one important exception is the O_3 formation reaction, in which a rare isotope effect leads to excess ^{17}O enrichment relative to what would be expected based on the ^{18}O enrichment (Thiemens 2006). This mass-independent effect leads to a unique signature (excess ^{17}O , termed $\Delta^{17}\text{O}$, quantified as $\Delta^{17}\text{O} = \delta^{17}\text{O} - (0.52 * \delta^{18}\text{O})$) in atmospheric O_3 ($\Delta^{17}\text{O}-\text{O}_3$) that is not affected by mass-dependent isotopic fractionations (Michalski, Savarino et al. 2002). Moreover, this mass-independent signal can be transferred to atmospheric NO_3^- in various degrees during NO_x oxidation reactions with O_3 , rendering measurement of $\Delta^{17}\text{O}-\text{NO}_3^-$ a robust tool to constrain photochemical formation pathways of atmospheric NO_3^- (Michalski et al., 2003; Alexander et al., 2009; Morin et al., 2011).

In the sections below, we highlight the current state of knowledge regarding: 1) the isotopic ratios of NO_x and NH_3 emission sources; 2) transformations in the atmosphere that can influence the fidelity of isotope ratios; 3) illustrative examples where isotopic approaches are used; and 4) methodological advances that have facilitated this burst of new knowledge. These highlights are not an exhaustive review of the literature, yet we hope they provide a glimpse of the potential for these methods to help resolve knowledge gaps regarding total Nr deposition to Earth surfaces.

State of the science

Inventory of $\delta^{15}\text{N}-\text{NO}_x$ and $\delta^{15}\text{N}-\text{NH}_3$ source values

Use of N isotopes in atmospheric Nr species as quantitative tracers of NO_x and NH_3 source contributions requires that different emission sources have relatively distinct and well-characterized $\delta^{15}\text{N}$ signatures. Globally, NO_x emissions from fossil fuel combustion via EGU and vehicles are the dominant NO_x source to the atmosphere (Figure 1).

Felix et al. (2012) collected EGU in-stack NO_x and found that EGU $\delta^{15}\text{N}-\text{NO}_x$ ranged from 9‰ to 26‰, significantly higher than that of other measured NO_x emission sources (Felix et al., 2012)(Figure 2a). NO_x resulting from vehicle fossil fuel combustion has been reported to have $\delta^{15}\text{N}$ values ranging from -13‰ to 9‰ and -21‰ to -2‰ for gasoline- and diesel-powered

vehicles, respectively (Figure 2a). Although $\delta^{15}\text{N}$ ranges of vehicle-emitted NOs and NO_x produced in biomass burning overlap to a large extent, vehicular $\delta^{15}\text{N}$ -NO_x measured either at tailpipes or in near-road environments is significantly higher than that of biogenic NO_x emissions from agricultural soils ranging from -60‰ to -20‰ (Figure 2a). The low $\delta^{15}\text{N}$ values of soil-emitted NO stem from large kinetic isotope effects associated with microbial NO production in soils that strongly discriminates ^{15}N (Yu and Elliott, 2017). Correspondingly, as shown in Figure 2, the $\delta^{15}\text{N}$ values of NO_x emission from EGU, vehicles, and soils are significantly different from each other, suggesting that $\delta^{15}\text{N}$ -NO_x is a robust indicator for NO_x source partitioning in relatively constrained environments (e.g., environments with *a priori* information on biomass burning and lightning) (Figure 2a).

Importantly, at the power plants studied in Felix et al. (2012), large differences exist in the $\delta^{15}\text{N}$ of NO_x emitted with and without selective catalytic reduction (SCR) technology (Figure 2a), indicating that EGU $\delta^{15}\text{N}$ -NO_x is altered by kinetic isotope effects during the catalytic NO_x reduction (Felix et al. 2012)(Figure 3a). This has also been observed in $\delta^{15}\text{N}$ of NO_x emitted from vehicles equipped with three-way catalytic converters (TWC) (Figure 3a), rendering vehicular $\delta^{15}\text{N}$ -NO_x dependent on vehicle operating conditions (e.g., cold versus warm engines) and NO_x mitigation efficiency (Walters et al. 2015a, b). Consequently, gradual implementation of emission control technologies (e.g., SCR and TWC) is expected to increase $\delta^{15}\text{N}$ -NO_x of fuel combustion-related NO_x emissions (Felix et al. 2012).

Global NH₃ emissions are dominated by agricultural activities, including livestock operations and fertilizer application (Figure 1). The primary agricultural source, urea in livestock waste and fertilizers, is quickly hydrolyzed to NH₃, which is then volatilized to the atmosphere. This is also the case with NH₄⁺ in fertilizers and hydrolyzed human waste where both are subject to direct volatilization after application and dissociation to NH₃. Hence, given the large equilibrium isotope effect associated with the aqueous NH₃-NH₄⁺ system (e.g., 45‰ at 23 °C (Li et al. 2012) and the kinetic isotope fractionation during NH₃ volatilization (Felix et al. 2013), field-observed $\delta^{15}\text{N}$ of NH₃ emitted from the agricultural sources (i.e., -56‰ to -10‰) is significantly lower than that of other anthropogenic and natural NH₃ emission sources (Figure 2b), allowing its potential use in tracing agricultural NH₃ emissions and their fate during atmospheric transformations. However, $\delta^{15}\text{N}$ -NH₃ derived in controlled laboratory incubations of liquid manure spans a wider range (Figure 2b) due to the strong temperature dependency of the equilibrium and kinetic isotope effects accompanying the NH₃ volatilization (Figure 3b), suggesting that $\delta^{15}\text{N}$ -NH₃ of the agricultural sources and human wastes may be subject to seasonal variations (Schulz et al. 2001).

Therefore, despite the indications that $\delta^{15}\text{N}$ -NO_x and $\delta^{15}\text{N}$ -NH₃ can serve as robust tracers of NO_x and NH₃ source contributions, further characterization of $\delta^{15}\text{N}$ -NO_x and $\delta^{15}\text{N}$ -NH₃ is required to minimize uncertainty and to further understand mechanisms driving $\delta^{15}\text{N}$ -NO_x and $\delta^{15}\text{N}$ -NH₃ dynamics. Moreover, the current inventory of $\delta^{15}\text{N}$ -NO_x and $\delta^{15}\text{N}$ -NH₃ source signatures is still limited, incomplete, and future efforts are needed to characterize diffuse,

non-fossil fuel-based sources, especially lightning and natural soils for $\delta^{15}\text{N-NO}_x$ and biomass burning, natural soils, and marine sources for $\delta^{15}\text{N-NH}_3$.

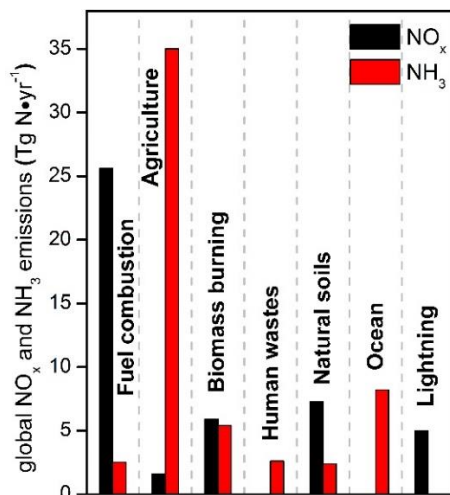

Figure 1. Global sources of NO_x and NH₃ for the 1990s (IPCC, 2013).

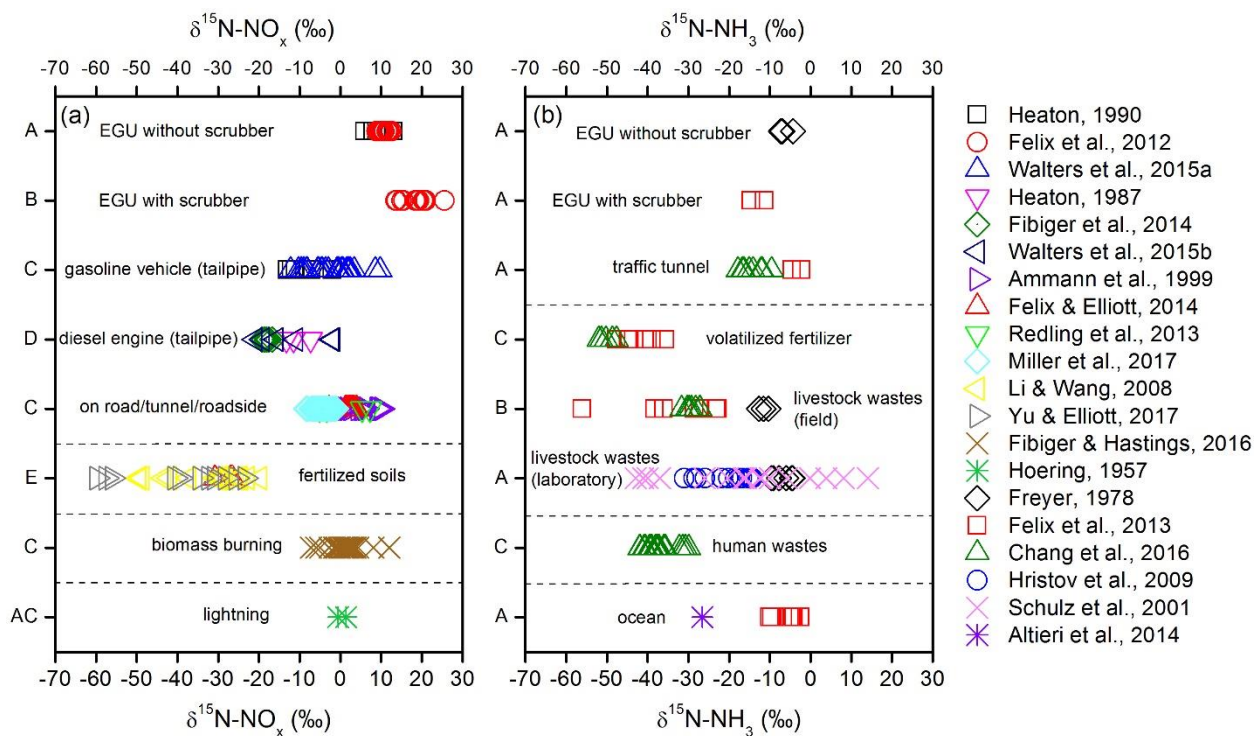

Figure 2. $\delta^{15}\text{N-NO}_x$ (a) and $\delta^{15}\text{N-NH}_3$ (b) values by emission sources. Different letters on the y-axis indicate significant difference between $\delta^{15}\text{N}$ values of different sources determined by one-way ANOVA and Bonferroni post hoc test. Dashed horizontal lines classify individual emission sources into source categories shown in Figure 1.

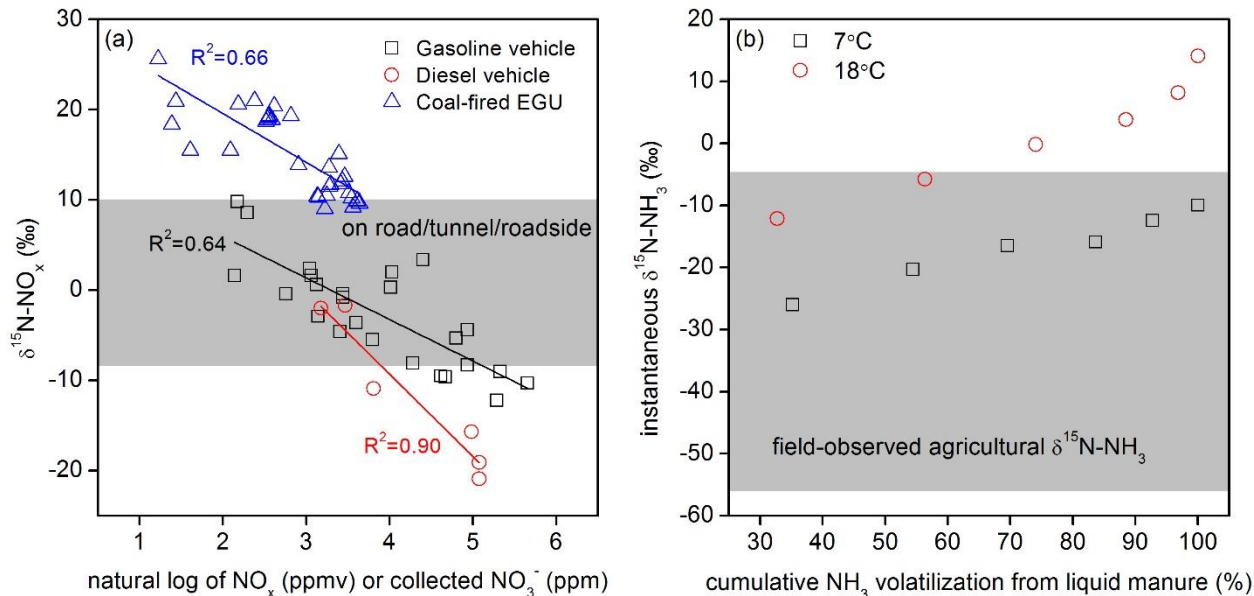
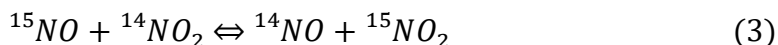
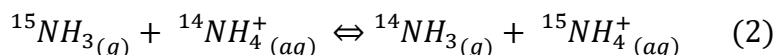

Figure 3. (a) $\delta^{15}\text{N-NO}_x$ of fuel combustion sources as a function of emitted NO_x concentration or collected NO_3^- concentration controlled by NO_x reduction technologies. Data are adapted from Felix et al. (2012), Walters et al. (2015a), and Walters et al. (2015b). Shaded area denotes range of $\delta^{15}\text{N-NO}_x$ measured on road, in traffic tunnels, and in roadside environments (see Figure 2a). (b) Instantaneous $\delta^{15}\text{N-NH}_3$ as a function of cumulative NH_3 volatilization from liquid manure under two different incubation temperatures. Data are adapted from Schultz et al. (2001). Shaded area denotes range of $\delta^{15}\text{N-NH}_3$ measured in livestock farms (see Figure 2b).

The role of atmospheric chemistry on isotopic signatures

Once released into the atmosphere, inorganic N_r gases such as NO_x and NH₃ undergo a number of physical and chemical processes that can alter their isotopic composition and the composition of their reaction products. These processes may be equilibrium (reversible) reactions, such as the partitioning of NH₃ between the gas and dissolved phase (Equation 2) or the exchange of an oxygen atom between NO and NO₂ (Equation 3):



The reaction described in Equation (2) has been shown in both theoretical calculations [Urey 1947] and laboratory experiments (Kirshenbaum et al. 1947; Li et al. 2012) to strongly favor the right hand side of the equilibrium, resulting in much higher ¹⁵N/¹⁴N ratios in dissolved NH₄⁺ than in NH₃. In support of the theory, simultaneous observations of NH₃ with particle-bound NH₄⁺ and/or NH₄⁺ in precipitation (Moore 1977; Heaton 1987; Savard et al. 2017) have found a

significantly higher proportion of ^{15}N in NH_4^+ , whether in the solid or aqueous phase, than in gas-phase NH_3 . However, the range of observed values is large, is not the same for wet and dry deposition, and both theory and observations predict a significant difference in the amount of isotopic fractionation in Equation (2) with ambient temperature (Urey 1947; Savard et al. 2017). These issues complicate the quantitative use of the ^{15}N signature in NH_3 or NH_4^+ for source attribution. Analogously, the gases NH_3 and NO_2 in equilibrium with soil or plant surfaces would be expected to be depleted in ^{15}N relative to their composition when emitted from primary sources.

The fractionation of N isotopes in Equation (3) and other atmospherically-relevant equilibrium reactions, and their temperature dependence, have been recently calculated from theoretical properties of several molecules (Walters and Michalski 2015). However, these fractionation factors: (a) apply only to equilibrium reactions, which many atmospheric reactions are not, and (b) have not all been verified or differ somewhat from experimental values. Equation (3) also favors the right hand side (heavier NO_2) according to these calculations, in qualitative agreement with limited atmospheric observations, but the composition of NO and NO_2 is also influenced by non-equilibrium reactions such as photolysis (Freyer et al. 1993).

Reactions that are not reversible, like photolysis, may have kinetic isotope effects rather than the equilibrium ones discussed above. One example is the formation of HNO_3 from N_2O_5 on wet surfaces (Equation 4):

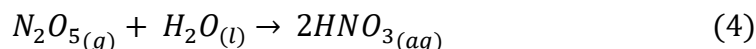

In these kinetic, irreversible reactions, the mechanism of the reaction can determine the amount and direction (i.e. whether the light or heavy isotope reacts faster) of isotope fractionation (Kaye 1987). For example, if the rate of the reaction in Equation (4) is limited only by the frequency of the N_2O_5 molecule colliding with the droplet or wet surface, the ^{15}N -containing molecule, which moves slightly slower than the lighter ^{14}N -containing molecule, will collide less frequently, leading to less ^{15}N in the HNO_3 product than in the N_2O_5 reactant. However, if the reaction proceeds through an intermediate complex (a “transition state”) that can be considered in equilibrium with the reactants, the isotope effect may be in the opposite direction, favoring HNO_3 with more ^{15}N . Due to the number and complexity of the NO_y ($=\text{NO} + \text{NO}_2 + \text{NO}_3 + \text{HNO}_3 + \text{N}_2\text{O}_5 + \text{HONO} + \text{particle NO}_3^- + \text{organic nitrates}$) reactions taking place in the atmosphere, linking the ^{15}N content of deposited nitrate (HNO_3 , $\text{NO}_3^-(\text{aq})$, and particle NO_3^-) to the ^{15}N content of emitted NO_x is not trivial. In addition to the source ^{15}N signatures, further experimental or field studies to determine empirical fractionation factors during atmospheric processing, under a range of conditions, may be required.

The vast majority of the isotope effects observed in nature, whether equilibrium or kinetic, depend in some way upon mass differences between the different isotopes (Kaye 1987) and are therefore called “mass-dependent”. One important exception is the O_3 formation reaction, in

which a rare isotope effect leads to excess ^{17}O enrichment relative to what would be expected based on the ^{18}O enrichment (Thiemens 2006). This effect leads to a unique signature (excess ^{17}O , termed $\Delta^{17}\text{O}$) that can be transferred to NO_y and other species when they react with O_3 or its products, is not affected by mass-dependent isotope effects, and is only erased when complete O exchange occurs with a much larger pool of mass-dependently fractionated O (e.g. a reservoir of liquid water). While there are a range of possible $\Delta^{17}\text{O}$ values in NO_y species depending on the local conditions and chemistry (Michalski 2003), the magnitude and robustness of the signal make it a feasible tool for estimating the contribution of atmospheric nitrate deposition to ecosystems, as discussed below.

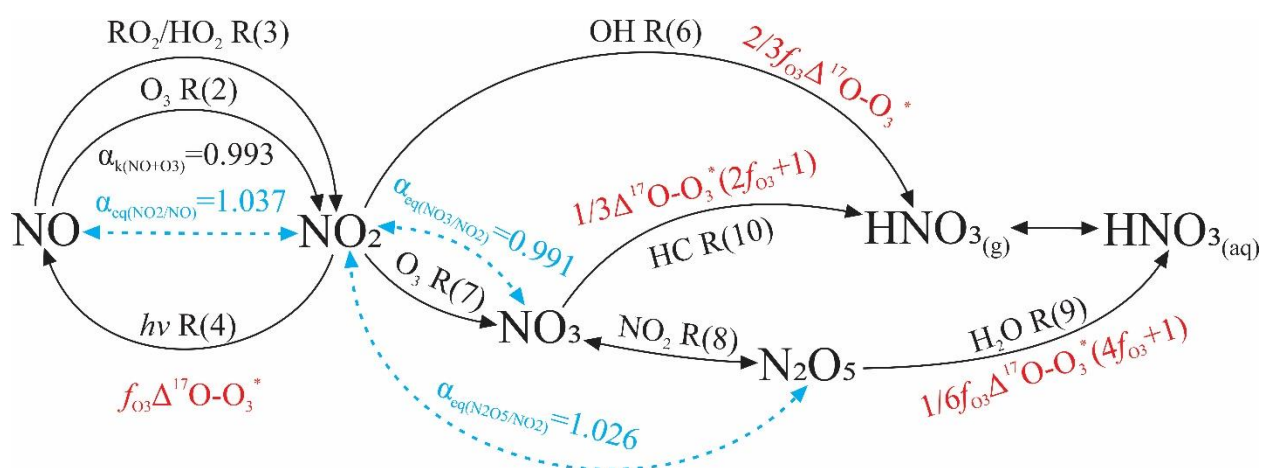

Figure 4. Chemistry leading to formation of atmospheric nitrate (black text and arrows) and corresponding N isotope exchange equilibrium (blue arrows and text) and $\Delta^{17}\text{O}$ transfer from O_3 to nitrate (red text). Calculated kinetic isotope effect for the $\text{NO} + \text{O}_3$ reaction ($\alpha_{\text{k}}(\text{NO}_2/\text{NO})$) is also shown.

Application studies of isotope distributions

Many experimental, field, and modeling studies have furthered our understanding of the source apportionment, seasonality, and atmospheric cycling influences on the isotopic composition of Nr species on both the atmosphere and in deposition. Spanning vast spatial scales, from the micro-scale through regional-sized gradient studies, studies measuring gaseous, particulate, and wet deposition, bulk plant/moss/fungi/soil, lake core, or ice core $\delta^{15}\text{N}$ values have attempted to characterize isotope dynamics and their corresponding changes over space and time.

Microscale gradient studies provide insight into how $\delta^{15}\text{N}$ values of NO_y and NH_x compounds are deposited with distance away from direct emission sources. For example, Ammann et al.

(1999) observed decreasing $\delta^{15}\text{N}$ values collected in spruce needles and soil along a ~ 1000 m gradient away from a highway and related $\delta^{15}\text{N}$ variations to the decreasing influence of mobile sourced NO_2 (Ammann et al. 1999). Similarly, Redling et al. (2013) presented isotopic evidence of NO_x source mixing on gaseous NO_2 and HNO_3 isotope dynamics along a ~ 500 m gradient downwind of a highway (Redling et al., 2013). Moreover, the researchers also traced the uptake of vehicle-source NO_2 into plant tissue using $\delta^{15}\text{N}$ of foliar Bentgrass as a biomonitor across the gradient (Redling et al. 2013). $\delta^{15}\text{N}\text{-NH}_3$ values have also been observed along microscale gradients in agricultural fields and used to estimate sources of gaseous NH_3 (Felix et al. 2014). Microscale gradient studies are particularly beneficial because long-range transport processes can be constrained. Most importantly, microscale deposition studies of NO_y/NH_x isotopes, using multiple ecosystem components (e.g. deposition, plants, soil, etc.), can provide a greater understanding of the how deposition fluxes influence biota and thus have important implications for critical load studies.

Ecosystem, regional, and national scale gradient studies of NO_y/NH_x isotopes in the atmosphere and in deposition have recently emerged in the literature and facilitated a greater understanding of the seasonality, atmospheric processes, and emission source influences on N isotopes. Isotopes of ambient forms of NO_x and/or NH_3 , and dry and/or wet deposited forms of NO_y , NH_3 , and/or secondary aerosols, particularly species of NO_3^- and NH_4^+ , have been well studied on regional scales and ecosystem localities around the globe (Elliott et al., 2007; Elliott et al., 2009; Zhang et al. 2008; Chang et al. 2016; Wankel et al. 2010; Savard et al. 2017; Savard et al. 2018; Kawashima and Kurahashi 2011; Jia and Chen 2010; Hastings et al. 2003; Felix et al. 2015; Felix et al. 2017; Walters et al. 2018; Liu et al. 2017; Pan et al. 2016; Pavuluri et al. 2010; Ti et al. 2018; Zong et al. 2017). Seasonal $\delta^{15}\text{N}\text{-NO}_3^-$ and $\delta^{15}\text{N}\text{-NH}_4^+$ values are generally lower in summer months and higher in winter months due to the combined influence of source changes, seasonal fluctuations in reaction chemistry, and fractionation factors that are temperature dependent (Beyn et al. 2015; Beyn et al. 2014; Freyer 1991; Elliott et al., 2007; Elliott et al. 2009). Lower $\delta^{15}\text{N}$ values in warm months generally reflect the importance of soil-derived biogenic emissions or lightning in some areas while cold month $\delta^{15}\text{N}$ values are more heavily influenced by fossil fuel combustion (electricity generation) (Elliott et al., 2007; Elliott et al., 2009; Hastings et al. 2003), although temperature dependence of isotopic equilibrium exchange between NO and NO_2 (Reaction 3) can also lead to more enriched $\delta^{15}\text{N}$ values during winter (Freyer 1991; Freyer et al. 1993).

In the rapidly expanding literature dedicated to $\delta^{15}\text{N}$ in atmospheric N and deposition, there is an active discussion regarding the relative influence of source signature and atmospheric processing as primary drivers for environmental $\delta^{15}\text{N}$ values. Recent studies demonstrate that $\delta^{15}\text{N}\text{-NO}_2$, source signatures remain intact under conditions of high O_3 concentration relative to NO_x concentration (i.e., f_{NO_2} close to 1) (Walters et al. 2018). Some regional field transect studies and paleo-studies have concluded that emission sources are the primary driver of $\delta^{15}\text{N}\text{-NO}_3^-$ and/or $\delta^{15}\text{N}\text{-NH}_4^+$ variations using back trajectory analyses (Beyn et al. 2014; Beyn et al. 2015; Fang et al. 2011; Wankel et al. 2010), emission sector comparisons (Elliott et al. 2007,

Elliott et al. 2009; Zhan et al. 2015), $\text{NH}_4^+/\text{NO}_3^-$ ratios (Beyn et al. 2014; Lee et al. 2012; Zhao et al. 2009;; Jia and Chen 2010), or using mixing models (Proemse et al. 2013; Felix et al. 2013; Felix et al. 2015; Felix et al. 2016; Chang et al. 2016; Liu et al. 2017; Pan et al. 2016; Zong et al. 2017; Ti et al. 2018; Chang et al., 2018). On the other hand, other studies highlight atmospheric processes (NO_x cycling, halogen chemistry, gas-particle phase partitioning, seasonal cycling, and PAN formation) as the dominant driver of $\delta^{15}\text{N}-\text{NO}_3^-$ and/or $\delta^{15}\text{N}-\text{NH}_4^+$ variations in marine boundary layer aerosol sampling (Morin et al. 2009, Vicars et al. 2013; Gobel et al. 2013; Savarino et al. 2013), stationary sampling with back trajectory analysis (Wankel et al. 2010; Altieri et al. 2013; Buda and DeWalle 2009; Savard et al. 2017; Pavuluri et al. 2010), and historical ice core $\delta^{15}\text{N}-\text{NO}_3^-$ studies (Geng et al. 2014). The most probable explanation for the large variations reported for NO_x/NH₃ isotopes in environmental systems is a combination of source and isotope effects. Additional effort is needed to quantify potential isotope effects on source signatures by supplementing traditional isotope sampling with multi-parameter sampling (e.g., NO_y, HNO₃, NH_x, SO_x, PM, trace metals, PAN, VOCs, and others) and CTMs (e.g., CMAQ, GEO-CHEM) to quantify reaction rates and interactions between meteorological conditions, emissions, and isotope effects. These types of analyses would further the community's understanding of atmospheric N reactions and their resulting deposited forms.

One additional way to observe isotope variations across time and space is by conducting spatial analyses to generate isoscapes (West et al. 2009 and references therein) where isoscapes are spatially explicit predictions of isotope ratios generated in a GIS using modeling tools such as inverse distance weighting. A previous study used isoscapes to characterize spatio-temporal variations in $\delta^{15}\text{N}-\text{NO}_3^-$ in wet deposition in the northeastern U.S. and was able to predict emission source contributions (Elliott et al. 2007). Isoscapes have been used to predict spatial variations in $\delta^{15}\text{N}-\text{NO}_x$ values in the U.S. based on primary vehicle emissions and commute time (Walters et al. 2015) and measured in the northeastern U.S. using in-situ $\delta^{15}\text{N}-\text{NO}_x$ sampling methods (Miller et al. 2017). Indeed, as more field sampling campaigns are conducted, isoscapes employed in conjunction with atmospheric processing models (e.g. CMAQ, GEOS-Chem) can implicitly integrate variations in $\delta^{15}\text{N}$ source signatures and isotopic fractionations over large spatial and temporal scales and are therefore expected to provide invaluable empirical information about the complex land-atmosphere interactions of NO_y and NH_x

Advances in field and laboratory isotopic methodologies

Analytical advances in characterizing small quantities of Nr in the late 1990s (Chang et al. 1999) and early 2000s (Silva C; Wilkison, DH; Ziegler, AC; Chang, CCY; Avanzino, RJ et al. 2000) have facilitated exponential growth in isotopic studies of atmospheric Nr. One such analytical advance is the use of denitrifying bacteria to analyze nanomolar quantities of nitrate for $\delta^{15}\text{N}$ (Sigman et al. 2001), $\delta^{18}\text{O}$ (Casciotti et al. 2002), and $\Delta^{17}\text{O}$ (Kaiser et al. 2004). Another analytical approach requiring higher sample masses (> 500 nmoles) is the chemical conversion of NO_3^- and NO_2^- to N_2O using either sodium azide, NaN_3 , (Mcilvin and Altabet 2005) or

hydroxylamine, H_3NO (Liu et al. 2014). Together, these methods established a new foundation for subsequent method development and application studies.

Gaseous nitric oxide, nitrogen dioxide, nitric acid, and ammonia

Gas phase N_r compounds can be characterized using either active or passive sampling approaches. Active sampling employs a pump to pass high volumes of air over a specialized filter or into solution. Alternatively, passive sampling approaches employ diffusive devices that expose specialized filters to ambient gases over longer-time scales (two weeks to six months). Passive samplers are advantageous in remote areas as they do not require power, integrate deposition over long-time scales, are relatively inexpensive, and are not labor intensive. Active sampling has the advantages of collecting larger samples in less time, simultaneous collection of multiple gases and particles, and the possibility of selecting for certain conditions such as wind direction from a nearby source (e.g. Smirnoff et al. 2012).

The isotopic characterization of NO and NO_x ($\text{NO} + \text{NO}_2 = \text{NO}_x$) has experienced a resurgence in interest (originally examined as early as 1967; Moore 1977) with a particular focus on characterizing fossil fuel NO_x. Starting in 1990, Heaton collected tailpipe and smokestack NO_x emissions in a solution of sodium hydroxide and hydrogen peroxide (Heaton and Anonymous 1990). Felix et al., 2012 modified an EPA stack sampling method (US EPA Method 7, Determination of Nitrogen Oxide Emissions from Stationary Sources) and compared the efficacy of sulfuric acid, sodium hydroxide, and triethanolamine (TEA) collection solutions for isotopic analysis of stack gases from coal-fired power plants in the U.S. (Felix et al. 2012). Walters et al. (2015) used the same EPA Method 7 to sample a series of vehicle tailpipe emissions (Walters et al. 2015a) as well as lawn equipment, buses, semi-trucks, and gas furnaces (Walters et al. 2015b). An alkaline permanganate solution has also been used to capture NO_x as NO_3^- for isotopic analysis (Fibiger et al. 2014) and was recently applied to on-road vehicle NO_x signatures in the U.S. (Miller et al. 2017), although this collection solution is subject to a high blank that makes it inappropriate for some field applications. Ambient NO₂ and/or NO_x have also been collected for ¹⁵N analysis using passive samplers (Smirnoff et al., 2012) or experimental actively-sampled cartridges (Savard et al., 2017) based on proprietary sampling media (Maxxam Analytics).

Soil NO emissions that emanate from soils as byproducts of nitrification and denitrification reactions, are more difficult to characterize due to their transient nature and low concentrations. Li et al. first characterized soil NO emissions in laboratory conditions where agricultural soil was fertilized and NO fluxes measured in a dynamic chamber (Li et al. 2007). NO was oxidized to NO₂ using chromate (CrO_4^{2-}) and the resulting NO₂ was captured using a tubular denuder coated in potassium hydroxide and guaiacol (Li et al. 2007). In a series of field chamber experiments, Homyak et al. used a ¹⁵N tracer and Ogawa NO_x filters in arid conditions where vegetation cover and soil moisture were manipulated to collect soil NO emissions (Homyak et al. 2016). More recently, Yu and Elliott established a method to characterize soil NO

emissions using a dynamic flux chamber where soil NO is oxidized to NO₂ in excess O₃, and resulting NO₂ is collected in a solution of TEA (Yu and Elliott 2017).

NO₂ for isotopic analysis has been captured using passive diffusion Ogawa samplers that contain a quartz filter impregnated with TEA (Redling et al. 2013; Felix and Elliott 2014). A recent study using controlled laboratory experiments determined precision and accuracy of Ogawa passive NO₂ filters as a collection medium for isotopic analysis of $\delta^{15}\text{N}$ and $\delta^{18}\text{O}$ across varying environmental conditions (Coughlin et al. 2017). Another recent study collected $\delta^{15}\text{N}$ and $\delta^{18}\text{O}$ of NO₂ using an active sampling denuder assembly coated with a potassium hydroxide solution, guaiacol, and methanol solution (Walters et al. 2018)

HNO₃ has been characterized isotopically using both active and passive sampling approaches. Archived HNO₃ from eight CASTNET sites, where HNO₃ is collected on a nylon filters as air is drawn through a three stage filter pack for a 1 week period, was analyzed for $\delta^{15}\text{N}$ and $\delta^{18}\text{O}$ (Elliott et al. 2009). Nylon filters were also used to collect HNO₃ downwind of specific source types using a wind sector-specific active sampling system for $\delta^{15}\text{N}$, $\delta^{18}\text{O}$ and $\delta^{17}\text{O}$ analysis (Savard et al., 2017). Passive collection of HNO₃, over several weeks to a month-long period, employs a Teflon pre-filter (2 mm pore size) and nylon collection medium (Elliott et al. 2009; Redling et al. 2013; Felix and Elliott 2014; Bell et al. 2014).

NH₃ can be collected for isotopic analysis on an acidified (phosphorous or citric acid) filter using a diffusive membrane pre-filter (Felix et al. 2013; Chang et al. 2016; Smirnov et al., 2012). Rather than the high mass requirements and other complications with filter combustion, Smirnov et al. (2012) and Felix et al. (2013) adapted an approach to oxidize NH₃ collected on acid-coated filters to nitrite using a bromate solution (Zhang et al 2007). These studies coupled oxidized NH₃ to the denitrifier method and thus allowed for the isotopic analysis of nanomolar quantities of NH₃ (Felix et al. 2013) or to the sodium azide conversion for larger samples (Smirnov et al., 2012). This analytical approach was then applied to field settings to characterize NH₃ emission sources (Felix et al. 2013) and partitioning to particulate NH₄⁺ downwind of sources (Savard et al., 2017), examine the fate of NH₃ emissions across field and landscape scales (Felix et al. 2014), as well as variability across large regions (Felix et al. 2017). A similar oxidation approach was used by Chang et al. (2016) to examine local and regional sources of NH₃ that contribute to PM_{2.5} formation in Beijing, China (Chang et al. 2016).

Precipitation, bulk deposition and throughfall

Reactive N in wet deposition, including rain, snow, and fog, can be characterized using several collection approaches. National monitoring networks, such as NADP's NTN, employ wet-only collectors that are exposed to the atmosphere only during precipitation events over a one-week period (i.e., each sample integrates wet deposition over a one-week period). Elliott et al. (2007), used archived NTN rainwater to examine spatio-temporal variations in $\delta^{15}\text{N}$ of nitrate in wet deposition across the Northeastern U.S. Finer time resolved samples have been used to examine changing nitrate sources to rainwater during Hurricane Irene (Felix et al. 2015) or

individual rain events (Buda and DeWalle 2009). Bulk collectors are continuously exposed to the atmosphere and are thus considered to collect both wet and dry deposition (e.g., (Zhang et al. 2008). Similarly, resin collectors that have long been used to passively measure Nr fluxes, have more recently been used as a medium for collection of bulk and throughfall nitrate deposition for isotopic analysis (Templer and Weathers 2011; Templer et al. 2015). The $\delta^{15}\text{N}$ values of NH_4^+ and nitrate in wet-only collectors were measured along with co-located particulate and gaseous species downwind of several sources in Alberta, Canada (Savard et al., 2017).

Particulates and aerosols containing nitrate or ammonium

Aerosol nitrate isotopes have been used in a similar fashion as wet nitrate deposition isotopes to examine emission sources and atmospheric cycling (Elliott et al. 2009; Wankel et al. 2010). In particular, particulate nitrate exhibits similar seasonal trends compared to wet nitrate isotopes wherein $\delta^{18}\text{O}$ values are higher in colder months due to relative proportion of oxygen atoms from isotopically enriched ozone to nitrate formation (Wankel et al. 2010). Particulate nitrate ^{15}N values were strongly correlated with surrounding power plant NO_x emission densities at eight CASTNET sites in Ohio, Pennsylvania, and New York (Elliott et al. 2009). Moreover, monthly variability in $\delta^{15}\text{N}$ of particulate nitrate aerosols at these same sites strongly mirrored monthly changes in emission densities surrounding individual sites (Elliott et al. 2009).

An analysis of $\delta^{15}\text{N}$ values of size segregated nitrate and NH_4^+ aerosols from coastal sites in the United Kingdom yielded a strong dependence on geographical origin of air masses and in particular that marine and terrestrial ammonia sources were isotopically distinct (Yeatman 2001).

More recently, Pan et al. (2016) used $\delta^{15}\text{N}$ values of size-resolved ammonia aerosols to determine that fossil fuel emissions of NH_3 were the dominant (90%) source of haze-forming NH_3 in Beijing, China (Pan et al. 2016). To distinguish between coarse and fine-mode aerosols, samples were collected using a 9-stage impactor and quartz fiber filters (Pan et al. 2016).

Lin et al. (2016) examined fine mode ($< 1 \mu\text{M}$ diameter) $\delta^{15}\text{N}$ of ammonium aerosols over the remote Atlantic ocean using a high volume sampler with a cascade impactor and Whatman 41 filters (Lin et al. 2016). They concluded that ammonia aerosols from the remote high latitudes had low $\delta^{15}\text{N}$ values relative to higher concentration ammonia aerosols collected in temperate and tropical latitudes (Lin et al. 2016).

Savard et al. (2017) analyzed $\delta^{15}\text{N}$ of particulate ammonium and nitrate downwind of different anthropogenic sources in Alberta, Canada, actively collected on open-face Teflon filters similar to those of CASTNET. Isotopic signatures in both particulate species overlapped for different source types, and the role of temperature-dependent isotope partitioning between the gas and particle phases was evident, particularly for ammonium and ammonia.

Future research

The first studies of atmospheric N isotopes began in the 1950s (Hoering, 1957), and the identification of isotope source signatures started as early as the 1970s (Moore, 1974). Despite the age of the techniques, the past decade has been marked by an explosion of research on atmospheric N isotopes. While much has been observed, modeled, and quantified during this past decade of research, further research is required to more fully apply isotopes to understanding atmospheric N chemistry and deposition. In particular, while existing studies demonstrate that isotopic ratios of atmospheric N have great promise to aid in source apportionment, the field needs further refinement before incorporation into regulatory contexts or frameworks.

Much of the needed future research will involve characterizing N isotopic signatures from emission sources. This will require two major components. First, a more robust inventory of emission source signatures for NO_x and NH₃ emission sources is required. While a handful of studies now exist that document ranges in isotope ratios for major emission sources, source signatures have not been explored extensively for all sources. Moreover, observations that focus on mechanisms driving variations in source signatures (e.g., effects of catalytic reduction technologies on vehicular $\delta^{15}\text{N-NO}_x$ and $\delta^{15}\text{N-NH}_x$, $\delta^{15}\text{N}$ of soil-emitted NO and NH₃ as a function of soil and environmental conditions) are extremely limited. We consider this research need to be a high priority that could be met in the short-term.

Secondly, further empirical experimental and field research is needed to characterize isotope effects (i.e., fractionations) that can occur in the atmosphere that can alter the fidelity of isotopic source signatures and the composition of ambient and/or deposited NO_y and NH_x. Because NO_y and NH_x cycling can complicate the interpretation of source apportionments to field-collected NO_x, HNO₃, NO₃⁻(d), NO₃⁻(w), organic nitrates, NH₃, NH₄⁺(d), NH₄⁺(w), and NH₄NO₃, empirical validation of recently modeled fractionation effects is imperative. Laboratory and field studies are needed to address the effects of field conditions, geographic scale, and atmospheric processes on resulting isotopic compositions of wet and dry deposited forms of NO_y and NH_x. Additional gradient studies, microscale to national-scale, should use all the most current methods available (i.e. NO_y and NH_x sampling, back trajectory analyses, mixing models, fractionation factors, NO_x/O₃ or NH₄⁺/NO₃⁻ information, as well as a multitude of other gaseous compounds). By using a combination of these toolsets, a more complete understanding will emerge of wet and dry deposited isotope variations in time and space. Manifestation of these spatio-temporal patterns as isoscapes will be an important interface between isotope geochemists, atmospheric chemists, modelers, ecologists, resource managers, and policy analysts and regulators. For this reason, we consider this overall research need to be a high priority that could be met in the short-term.

Additionally, there are other key toolsets that can be utilized to further the scientific community's understanding of atmospheric N compound reactions and their resulting influence

on the environment. While future efforts would aim to quantify potential isotope effects on emission source signatures by supplementing traditional isotope sampling with multi-parameter sampling (e.g., NO, NO₂, NO/NO₂, HNO₃ concentrations), chemical transport modeling (e.g., CMAQ, GEOS-CHEM) can also be used in conjunction with sampling to quantify reaction rates and interactions between meteorological conditions, emissions, and isotope effects. As understanding of the isotopic chemistry of atmospheric N evolves, isotopic ratios can be extremely useful for CTMs. For example, isotopic methods could be used to empirically validate the relative contributions of hard-to-quantify emission sources such as lightning and diffuse soil NO emissions. Additionally, isotopes can be used as tracers within atmospheric chemistry models to provide empirical validation of chemical reactions, furthering the understanding of atmospheric reactions that are currently unknown. They can also play a significant role in the development of accurate “transference ratios” used by models to quantify deposition fluxes to landscapes and the subsequent impact of that deposition to surface water N loads. We consider this overall research need to be a medium priority that could be met in the mid-term.

While $\Delta^{17}\text{O-NO}_3^-$ is a robust tracer of photochemical NO₃⁻ production in the atmosphere, there is also tremendous potential for the application of $\Delta^{17}\text{O-NO}_3^-$ to understand the impact of atmospheric NO₃⁻ deposition on ecosystems, including streams and rivers. To date, only a handful of studies have used this approach. Given that $\Delta^{17}\text{O}$ is a conservative tracer, it can be used to quantify atmospheric nitrate contributions to water bodies, as well as quantify the effects of mass-dependent processes like denitrification. Expansion of this approach to quantify the relative proportion of atmospheric nitrate in streams and rivers beyond existing studies would help refine our general understanding of N_r dynamics in watersheds and ecosystems. There are several groups pursuing this technique (e.g. Rose et al. 2015; Michalski, 2004) that may be points of key research opportunities for parties interested in applying the technique to samples collected in national monitoring networks (government/academic collaborations). There is great potential for the use of this technique by environmental program managers to determine sources of N contamination in water bodies, for example, discerning a runoff or atmospheric N deposition source. This information, on level 3-4 ecoregion scales, would provide highly desirable information to key decision makers for determining appropriate standards (e.g., secondary NO₂ NAAQS) in protecting environmental health. We consider this future research to be a medium priority that can be met in the short-term.

Lastly, the aforementioned future research would benefit from a clearer recognition of the importance of atmospheric deposition within the field of “atmospheric chemistry”. In particular, funding through federal agencies can be siloed into disciplinary categories. While atmospheric deposition clearly plays a role in individual disciplines (e.g., Ecosystem Studies, Hydrological Sciences, Atmospheric Chemistry, etc.), research involving atmospheric deposition is not clearly identified in categories outlined through federal funding organizations. It is certainly the case that cross coordination is required across different disciplines to address the

opportunities questions outlined in this future research section. For example, isotope geochemists, field monitoring researchers, global modelers, and others will be required to collaborate to answer some of the larger remaining questions pertaining to atmospheric N compound dynamics. Resolving potential funding venues for atmospheric deposition research is an immediate need and one that could be addressed in the short-term through conversations and collaborations between academic researchers and scientists at federal and state agencies.

References

Altieri, K. E., Hastings M. G., Gobel A. R., Peters A. J., Sigman D. M. (2013). Isotopic composition of rainwater nitrate at Bermuda: The influence of air mass source and chemistry in the marine boundary layer. *Journal of Geophysical Research: Atmospheres*, 118(19).

Ammann M., Siegwolf R., Pichlmayer F., Suter M., Saurer M., Brunold C. (1999). Estimating the uptake of traffic-derived NO₂ from ¹⁵N abundance in Norway spruce needles. *Oecologia*, 118(2), 124-131.

Bell M.D., Sickman J.O., Bytnerowicz A., et al (2014) Variation in isotopologues of atmospheric nitric acid in passively collected samples along an air pollution gradient in southern California. *Atmos Environ* 94, 287–296. doi: 10.1016/j.atmosenv.2014.05.031

Beyn F., Matthias V., Dähnke K. (2014). Changes in atmospheric nitrate deposition in Germany—an isotopic perspective. *Environmental Pollution*, 194, 1-10.

Beyn F., Matthias V., Aulinger A., Dähnke K. (2015). Do N-isotopes in atmospheric nitrate deposition reflect air pollution levels? *Atmospheric Environment*, 107, 281-288.

Buda A.R., DeWalle D.R. (2009) Using atmospheric chemistry and storm track information to explain the variation of nitrate stable isotopes in precipitation at a site in central Pennsylvania, USA. *Atmos Environ* 43:4453–4464. doi: 10.1016/j.atmosenv.2009.06.027

Casciotti K.L.L., Sigman D. M., Hastings M.G.G., et al (2002) Measurement of the oxygen isotopic composition of nitrate in seawater and freshwater using the denitrifier method. *Anal Chem* 74:4905–4912. doi: 10.1021/ac020113w

Chang C.C.Y., Langston J., Riggs M., et al (1999) A method for nitrate collection for $\delta^{15}\text{N}$ and $\delta^{18}\text{O}$ analysis from waters with low. *1864:1856–1864*.

Chang Y., Liu X., Deng C., Dore A. J., Zhuang G. (2016) Source apportionment of atmospheric ammonia before, during, and after the 2014 APEC summit in Beijing using stable nitrogen isotope signatures. *Atmospheric Chemistry and Physics* 16, 11635-11647. doi: 10.5194/acp-2016-432

Coughlin J.G., Yu Z., Elliott E.M. (2017) Efficacy of Passive Sampler Collection for Atmospheric NO₂ Isotopes under Simulated Environmental Conditions. *Rapid Commun Mass Spectrom*. doi:

10.1002/rcm.7885

Elliott E.M., Kendall C., Boyer E.W., et al (2009) Dual nitrate isotopes in dry deposition: Utility for partitioning NO_x source contributions to landscape nitrogen deposition. *J Geophys Res Biogeosciences* 114, 1–15. doi: 10.1029/2008JG000889

Elliott E.M., Kendall C., Wankel S.D., et al (2007) Nitrogen Isotopes as Indicators of NO_x Source Contributions to Atmospheric Nitrate Deposition Across the Midwestern and Northeastern United States. *Environ Sci Technol* 41, 7661–7667. doi: 10.1021/es070898t

Fang Y.T., Koba K., Wang X.M., Wen D.Z., Li J., Takebayashi Y., ... , Yoh, M. (2011). Anthropogenic imprints on nitrogen and oxygen isotopic composition of precipitation nitrate in a nitrogen-polluted city in southern China. *Atmospheric Chemistry and Physics*, 11(3), 1313–1325.

Felix J.D., Elliott E.M. (2014) Isotopic composition of passively collected nitrogen dioxide emissions: Vehicle, soil and livestock source signatures. *Atmos Environ* 92, 359–366. doi: 10.1016/j.atmosenv.2014.04.005

Felix J.D., Elliott E.M., Avery G.B., et al (2015) Isotopic composition of nitrate in sequential Hurricane Irene precipitation samples: Implications for changing NO_x sources. *Atmos Environ* 106, 191–195. doi: 10.1016/j.atmosenv.2015.01.075

Felix J.D., Elliott E.M., Gay D.A. (2017) Spatial and temporal patterns of nitrogen isotopic composition of ammonia at U.S. ammonia monitoring network sites. *Atmos Environ* 150, 434–442. doi: 10.1016/j.atmosenv.2016.11.039

Felix J.D., Elliott E.M., Gish T., et al (2014) Examining the transport of ammonia emissions across landscapes using nitrogen isotope ratios. *Atmos Environ* 95, 563–570. doi: 10.1016/j.atmosenv.2014.06.061

Felix J.D., Elliott E.M., Gish T.J., et al (2013) Characterizing the isotopic composition of atmospheric ammonia emission sources using passive samplers and a combined oxidation-bacterial denitrifier approach. *Rapid Commun Mass Spectrom* 27, 1–8. doi: 10.1002/rcm.6679

Felix J.D., Elliott E.M., Shaw S.L. (2012) Nitrogen Isotopic Composition of Coal-Fired Power Plant NO: Influence of Emission Controls and Implications for Global Emission Inventories. *Environ Sci Technol*, 46 (6), 3528–3535.

Fibiger D.L., Hastings M.G., Lew A.F., Peltier R.E. (2014) Collection of NO and NO₂ for Isotopic Analysis of NO_x Emissions. *Anal Chem* 86, 12115–12121. doi: 10.1021/ac502968e

Freyer, H.D. (1991) Seasonal variation of ¹⁵N/¹⁴N ratios in atmospheric nitrate species. *Tellus B*, 43(1), 30–44.

Freyer H., Kley D., Volz-Thomas A., Kobel K. (1993) On the interactions of isotopic exchange

processes with photochemical reactions in atmospheric oxides of nitrogen. *J Geophys Res* 98, 14791–14796.

Geng L., Alexander B., Cole-Dai J., Steig E.J., Savarino J., Sofen E. D., Schauer, A.J. (2014) Nitrogen isotopes in ice core nitrate linked to anthropogenic atmospheric acidity change. *Proceedings of the National Academy of Sciences*, 111(16), 5808-5812.

Gobel A.R., Altieri K.E., Peters A.J., Hastings M.G., Sigman, D.M. (2013) Insights into anthropogenic nitrogen deposition to the North Atlantic investigated using the isotopic composition of aerosol and rainwater nitrate. *Geophysical Research Letters*, 40(22), 5977-5982.

Hastings M.G., Sigman D.M., & Lipschultz F. (2003) Isotopic evidence for source changes of nitrate in rain at Bermuda. *Journal of Geophysical Research: Atmospheres*, 108(D24).

Heaton T.H.E., Anonymous. (1990) $^{15}\text{N}/^{14}\text{N}$ ratios of NO_x from vehicle engines and coal-fired power stations. *Tellus* 42B,304–307.

Heaton T.H.E. (1987) $^{15}\text{N}/^{14}\text{N}$ ratios of nitrate and ammonium in rain at Pretoria, South Africa. *Atmos Environ* 21:843–852.

Homyak P.M., Blankinship J.C., Marchus K. et al (2016) Aridity and plant uptake interact to make dryland soils hotspots for nitric oxide (NO) emissions. *Proc Natl Acad Sci* 113, E2608–E2616. doi: 10.1073/pnas.1520496113

Hoering, T. (1957). The isotopic composition of the ammonia and the nitrate ion in rain. *Geochimica et Cosmochimica Acta*, 12(1-2), 97-102.

Kaiser J., Hastings M.G., Houlton B.Z., et al (2004) Triple Oxygen Isotope Analysis of Nitrate Using the Denitrifier Method and Thermal Decomposition of N_2O . *Anal Chem* 79, 2175–2181. doi: 10.1021/ac0256282.(9)

Kawashima H., Kurahashi, T. (2011) Inorganic ion and nitrogen isotopic compositions of atmospheric aerosols at Yurihonjo, Japan: Implications for nitrogen sources. *Atmospheric Environment* 45, 6309-6316.

Kaye J.A. (1987) Mechanisms and observations for isotope fractionation of molecular species in planetary atmospheres. *Rev Geophys* 25, 1609–1658. doi: 10.1029/RG025i008p01609

Kirshenbaum I., Smith J.S., Crowell T., et al (1947) Separation of the Nitrogen Isotopes by the Exchange Reaction between Ammonia and Solutions of Ammonium Nitrate. *J Chem Phys* 15, 440. doi: 10.1063/1.1746562

Lee K.S., Lee D.S., Lim S.S., Kwak J.H., Jeon B.J., Lee S.I., ... , Choi, W.J. (2012) Nitrogen isotope ratios of dissolved organic nitrogen in wet precipitation in a metropolis surrounded by agricultural areas in southern Korea. *Agriculture, ecosystems & environment*, 159, 161-169.

Li D., Wang X., Mo J., et al (2007) Soil nitric oxide emissions from two subtropical humid forests

in south China. 112, 1–9. doi: 10.1029/2007JD008680

Li L., Lollar B.S., Li H., et al (2012) Ammonium stability and nitrogen isotope fractionations for $\text{NH}_3(\text{aq})\text{--NH}_3(\text{gas})$ systems at 20–70°C and pH of 2–13: Applications to habitability and nitrogen cycling in low-temperature hydrothermal systems. *Geochim Cosmochim Acta* 84, 280–296. doi: 10.1016/j.gca.2012.01.040

Lin C.T., Jickells T.D., Baker A.R., et al (2016) Aerosol isotopic ammonium signatures over the remote Atlantic Ocean. *Atmos Environ* 133, 165–169. doi: 10.1016/j.atmosenv.2016.03.020

Liu X.Y., Xiao H.W., Xiao H. Y., Song W., Sun X.C., Zheng X.D., Liu C.Q., Koba, K. (2017) Stable isotope analyses of precipitation nitrogen sources in Guiyang, southwestern China. *Environmental Pollution* 230, 486–494.

Liu D., Fang Y., Tu Y., Pan Y. (2014) A new chemical method for nitrogen isotopic analysis of ammonium at natural abundance. *Anal Chem* 86, 3787–3792. doi: dx.doi.org/10.1021/ac403756u

Mcilvin M.R., Altabet M.A. (2005) Chemical conversion of nitrate and nitrite to nitrous oxide for nitrogen and oxygen isotopic analysis in freshwater and seawater. *Anal Chem* 77, 5589–95. doi: 10.1021/ac050528s

Michalski G. (2003) First measurements and modeling of $\Delta^{17}\text{O}$ in atmospheric nitrate. *Geophys Res Lett* 30, 3–6. doi: 10.1029/2003GL017015

Miller D.J., Wojtal P.K., Clark S.C., Hastings M.G. (2017) Vehicle NO_x emission plume isotopic signatures: spatial variability across the eastern United States. *J Geophys Res Atmos* 4698–4717. doi: 10.1002/2016JD025877

Moore H. (1977) The isotopic composition of ammonia, nitrogen dioxide, and nitrate in the atmosphere. *Atmos Environ* 11, 1239–1243.

Morin S., Savarino J., Frey M.M., Domine F., Jacobi H.W., Kaleschke L., Martins, J.M. (2009) Comprehensive isotopic composition of atmospheric nitrate in the Atlantic Ocean boundary layer from 65 S to 79 N. *Journal of Geophysical Research: Atmospheres*, 114(D5).

Pan Y., Tian S., Liu D., et al (2016) Fossil fuel combustion-related emissions dominate atmospheric ammonia sources during severe haze episodes: Evidence from ^{15}N -stable isotope in size-resolved aerosol ammonium. *Environ. Sci. Tech.* 50 (15), 8049 - 8056. doi: 10.1021/acs.est.6b00634

Pavuluri C.M., Kawamura K., Tachibana E., Swaminathan T. (2010) Elevated nitrogen isotope ratios of tropical Indian aerosols from Chennai: Implication for the origins of aerosol nitrogen in South and Southeast Asia. *Atmospheric Environment* 44, 3597–3604.

Petit J.R., Jouzel J., Raynaud D., Barkov N.I., Barnola J.M., Basile I., Bender M., Chappellaz J.,

Davis M., Delaygue G., Delmotte M., Kotlyakov V.M., Legrand M., Lipenkov V.Y., Lorius C., Pépin L., Ritz C., Saltzman E., Stievenard M. (1999) Climate and atmospheric history of the past 420,000 years from the Vostok ice core, Antarctica. *Nature* 399, 429.

Proemse B.C., Mayer B., Fenn M.E., Ross C.S. (2013) A multi-isotope approach for estimating industrial contributions to atmospheric nitrogen deposition in the Athabasca oil sands region in Alberta, Canada. *Environmental pollution*, 182, 80-91.

Redling K.M., Elliott E.M., Bain D.J., Sherwell J. (2013) Highway contributions to reactive nitrogen deposition: Tracing the fate of vehicular NO_x using stable isotopes and plant biomonitors. *Biogeochemistry*, 261–274. doi: 10.1007/s10533-1013-9857-x

Savard M.M., Cole A., Smirnoff A., Vet R. (2017) $\delta^{15}\text{N}$ values of atmospheric N species simultaneously collected using sector-based samplers distant from sources – Isotopic inheritance and fractionation. *Atmos Environ* 162, 11–22. doi: 10.1016/j.atmosenv.2017.05.010

Savard M.M., Cole A.S., Vet R., Smirnoff A. (2018) The $\Delta^{17}\text{O}$ and $\delta^{18}\text{O}$ values of atmospheric nitrates simultaneously collected downwind of anthropogenic sources – implications for polluted air masses. *Atmos Chem Phys* 18, 10373-10389. doi:10.5194/acp-18-10373-2018

Savarino J., Morin S., Erbland J., Grannec F., Patey M.D., Vicars W., ... , Achterberg E.P. (2013) Isotopic composition of atmospheric nitrate in a tropical marine boundary layer. *Proceedings of the National Academy of Sciences*, 110(44), 17668-17673.

Schulz H., Gehre M., Hofmann D., Jung K. (2001) Nitrogen isotope ratios in pine bark as an indicator of N emissions from anthropogenic sources. *Environ Monit Assess* 69, 283–97.

Sigman D.M., Casciotti K.L.L., Andreani M., et al (2001) A bacterial method for the nitrogen isotopic analysis of nitrate in seawater and freshwater. *Anal Chem* 73, 4145–53.

Silva S.R., Kendall C., Wilkison D.H., Ziegler A.C., Chang, C.C.Y.; Avanzino, R.J. (2000) A new method for collection of nitrate from fresh water and the analysis of nitrogen and oxygen isotope ratios. *J Hydrol* 228, 22–36.

Templer P.H., Weathers K.C., Ewing H.A., et al (2015) Fog as a source of nitrogen for redwood trees: Evidence from fluxes and stable isotopes. *J Ecol* 103, 1397–1407. doi: 10.1111/1365-2745.12462

Templer P.H., Weathers K.C. (2011) Use of mixed ion exchange resin and the denitrifier method to determine isotopic values of nitrate in atmospheric deposition and canopy throughfall. *Atmos Environ* 45, 2017–2020. doi: 10.1016/j.atmosenv.2011.01.035

Thiemens M.H. (2006) History and Applications of Mass-Independent Isotope Effects. *Annu Rev Earth Planet Sci* 34, 217–262. doi: 10.1146/annurev.earth.34.031405.125026

Ti C.P., Gao B., Luo Y.X., Wang X., Wang S.W., Yan, XY. 2018. Isotopic characterization of NH_x-N

in deposition and major emission sources. *Biogeochemistry* 13, 85-102.

Tsunogai U., Komatsu D.D., Daita S., et al (2010) Tracing the fate of atmospheric nitrate deposited onto a forest ecosystem in Eastern Asia using $\Delta^{17}\text{O}$. *Atmos Chem Phys* 10, 1809–1820. doi: 10.5194/acp-10-1809-2010

Tsunogai U., Miyauchi T., Ohyama T., et al (2016) Accurate and precise quantification of atmospheric nitrate in streams draining land of various uses by using triple oxygen isotopes as tracers. *Biogeosciences* 13, 3441–3459. doi: 10.5194/bg-13-3441-2016

Urey H.C. (1947) The Thermodynamic Properties of Isotopic Substances. *J Chem Soc*, April 1947: 562–581.

Vicars W.C., Morin S., Savarino J., Wagner N.L., Erbland J., Vince E., ... , Williams, E.J. (2013) Spatial and diurnal variability in reactive nitrogen oxide chemistry as reflected in the isotopic composition of atmospheric nitrate: Results from the CalNex 2010 field study. *Journal of Geophysical Research: Atmospheres*, 118 (18).

Walters W.W., Goodwin S.R., Michalski G. (2015a) Nitrogen stable isotope composition ($\delta^{15}\text{N}$) of vehicle-emitted NO_x. *Environ Sci Technol* 49, 2278–2285. doi: 10.1021/es505580v

Walters W.W., Michalski G. (2015) Theoretical calculation of nitrogen isotope equilibrium exchange fractionation factors for various NO_y molecules. *Geochim Cosmochim Acta* 164, 284–297. doi: 10.1016/j.gca.2015.05.029

Walters W.W., Tharp B.D., Fang H., et al (2015b) Nitrogen Isotope Composition of Thermally Produced NO. doi: 10.1021/acs.est.5b02769

Walters W.W., Fang H., Michalski G. (2018) Summertime diurnal variations in the isotopic composition of atmospheric nitrogen dioxide at a small midwestern United States city. *Atmospheric Environment* 179, 1-11.

Wankel S.D., Chen Y., Kendall C., et al (2010) Sources of aerosol nitrate to the Gulf of Aqaba: Evidence from $\delta^{15}\text{N}$ and $\delta^{18}\text{O}$ of nitrate and trace metal chemistry. *Mar Chem* 120, 90–99. doi: 10.1016/j.marchem.2009.01.013

West J.B., Bowen G.J., Dawson T.E., Tu K.P. (Eds.) (2009) *Isoscapes: understanding movement, pattern, and process on Earth through isotope mapping*. Springer Science & Business Media.

Yeatman S. (2001) Comparisons of coarse-mode aerosol nitrate and ammonium at two polluted coastal sites. *Atmos Environ* 35, 1337–1345. doi: 10.1016/S1352-2310(00)00452-0

Yu Z., Elliott E.M. (2017) Novel Method for Nitrogen Isotopic Analysis of Soil-Emitted Nitric Oxide. *Environ. Sci. Technol.*, 51 (11), 6268–6278. doi: 10.1021/acs.est.7b00592

Zhan X., Yu G., He N., Jia B., Zhou M., Wang C., ... , Yan J. (2015) Inorganic nitrogen wet deposition: evidence from the north-south transect of Eastern China. *Environmental pollution*,

204, 1-8.

Zhao, X., Yan, X., Xiong, Z., Xie, Y., Xing, G., Shi, S., & Zhu, Z. (2009). Spatial and temporal variation of inorganic nitrogen wet deposition to the Yangtze River Delta Region, China. *Water, air, and soil pollution*, 203(1-4), 277-289.

Zhang L., M. A. Altabet, T. Wu, O. Hadas (2007). Sensitive measurement of $\text{NH}_4^+ \text{}^{15}\text{N}/\text{}^{14}\text{N}$ ($\delta^{15}\text{NH}_4^+$) at natural abundance levels in fresh and saltwaters. *Anal Chem* 79, 5297

Zhang Y, Liu XJ, Fangmeier A, et al (2008) Nitrogen inputs and isotopes in precipitation in the North China Plain. 42:1436–1448. doi: 10.1016/j.atmosenv.2007.11.002

Zong, Z., X. Wang, C. Tian, Y. Chen, Y. Fang, F. Zhang, C. Li, J. Sun, J. Li, and G. Zhang. 2017. First Assessment of NO_x Sources at a Regional Background Site in North China Using Isotopic Analysis Linked with Modeling. *Environ Sci Technol* 51:5923-5931.

3.4. Spatial and Temporal Patterns of Total Nr Deposition

Over the past few decades a relationship in declining trends between emissions of NO_y and SO₂ and their ambient concentrations has been observed by emissions monitoring and ambient monitoring networks. For Nr species, this decline in NO_y has been accompanied by steady to slightly increasing concentrations of Nr in reduced forms (NH₃ + NH₄⁺). Data from long-term national-scale monitoring networks have been instrumental in assessing these spatial and temporal trends and providing accountability for emission reduction programs, which is discussed in Section ***3.4.1. Relationship between long-term Nr trends in emissions and deposition***. Background is provided and knowledge gaps as to how these monitoring strategies can evolve to provide more information on spatial and temporal patterns of species key to the total Nr budget is discussed. A key limitation is the understanding of the spatial and temporal variability in atmospheric NH₃, especially near and downwind of large scale agricultural sources. This topic is discussed in Section ***3.4.2. Spatial variability of ammonia in agricultural regions***.

3.4.1. Relationship of long-term Nr trends in emission and deposition

Gregory M. Beachley¹, Christopher M. Rogers², Thomas F. Lavery³

¹U.S. EPA, Office of Air and Radiation, Washington, DC

²Wood Environment & Infrastructure Solutions, Jacksonville, FL

³Environmental Consultant, Cranston, RI

Research topic summary

The long-term monitoring of ambient air quality data under consistent quality assurance protocols is necessary to evaluate trends in Nr deposition. Existing datasets in the U.S. were collected to monitor pollutants (SO₂, NO_x, PM_{2.5}, O₃) associated with acid rain production and to track the efficacy of pollution mitigation regulation on EGUs. Current long-term monitoring data directly relevant to Nr deposition includes concentrations of NO₃⁻ and NH₄⁺ in precipitation, ambient concentrations of gaseous HNO₃, NO_x, particulate NO₃⁻ (pNO₃) and NH₄⁺ (pNH₄), and more recently, ambient concentrations of gaseous NH₃.

There has been work on the regional and national levels to establish linkages between Nr emissions reductions and ambient Nr monitoring concentrations. There is a need to review these studies and to quantify the impacts those reductions may have had on Nr deposition that could be met in the near-term. Existing measurements could also be used to evaluate biases in deposition models that can impact long-term trends. As deposition models improve with the advancement of science, efforts need to be made to preserve consistency of past deposition estimates with modern estimates. However, it may be difficult to quantify those impacts and to effectively assess trends in Nr deposition in that long-term Nr monitoring data is limited.

Current monitoring networks need to incorporate new sampling strategies to address the lack of spatially and temporally resolved Nr measurements of species significant to the deposition budget. Some of these research needs could be met in the near-term, such as expanding current monitoring networks to include sites in urban, coastal, or agricultural areas to increase the sampling presence in areas of high or unknown spatial variability. Also, passive samplers for NO₂ could be added to existing infrastructure of the NADP/AMoN. There are current studies to adapt existing high-resolution NO_x measurements to expand the number of species of oxidized Nr and to include reduced Nr.

In the longer-term, current monitoring networks need to consider development of analytical methods to measure unmeasured Nr species (e.g. bulk ON in precipitation) that contribute to overall Nr deposition trends, and to establish low-cost standardized integrated direct deposition measurements that can be deployed within existing network infrastructure. To the extent possible, remote sensing data for NO₂ and NH₃ could be compared with existing surface

monitoring concentrations and evaluated to further characterize spatial and temporal variability of those species.

Introduction

Long-term monitored trends of air pollution are a valuable resource in the field of deposition science. Ambient concentrations and deposition for many NAAQS pollutants have been on a downward trend since coordinated, national air pollutant monitoring networks were established in the late 1970s and the 1980s in conjunction with pollution mitigation efforts on EGUs. Most of these monitoring efforts have been focused on oxidized pollutants and PM and their role in acid rain production rather than on Nr species. As the importance of Nr as a pollutant has increased with concern about its role in ecosystem impacts such as eutrophication and loss of species diversity (for example, Bobbink et al., 2010), trends in Nr deposition need to be better evaluated. The evaluation of long-term monitoring trends serves to 1) quantify the amount of pollution in the air and entering an ecosystem; 2) track changes in emissions, concentrations and deposition over time to assess the effectiveness of national and regional air pollution control programs; and 3) to help understand impacts due to changing atmospheric chemistry.

Long-term monitoring datasets are rare because of the difficulty and capital required to collect consistent and accurate results over time. In addition to this, the spatial coverage of monitoring sites requires a centralized operation with consistent quality assurance guidelines over both field-collection and laboratory analysis procedures. In the U.S., much of the current air monitoring infrastructure is in place to monitor NAAQS pollutants. As an example, the U.S. EPA CASTNET (<https://www.epa.gov/castnet>, accessed October 10, 2018) was established in response to the U.S. Congress mandate in the 1990 Clean Air Act Amendments (CAAA) that EPA provide consistent, long-term measurements for determining relationships between changes in emissions and subsequent changes in air quality, atmospheric deposition, and ecological effects. While many of the analytes measured by CASTNET are focused on acid rain precursors emitted by EGUs, a few are directly relevant to Nr deposition (e.g. HNO_3 , NO_3^- , NH_4^+). There are opportunities to expand on existing infrastructure to include new sampling strategies that would allow for long-term and consistent spatially and temporally resolved Nr measurements.

Existing North American long-term monitoring networks that measure wet deposition and monitor ambient concentrations to estimate dry deposition of Nr species includes the U.S. EPA CASTNET, the NADP/NTN (<http://nadp.slh.wisc.edu/NTN/>), NADP/AMoN (<http://nadp.slh.wisc.edu/AMoN/>) and the NADP/AIRMoN (<http://nadp.slh.wisc.edu/airmon/>), Canada's CAPMoN (<https://www.canada.ca/en/environment-climate-change/services/air-pollution/monitoring-networks-data/canadian-air-precipitation.html>) and provincial networks. Specific details on these networks and maps of site locations are included in Section **3.2.4**.

Assessing uncertainty in total Nr deposition estimates for North American critical load applications. In addition, measurements are made of ambient NO_x and oxidized nitrogen (NO_y) concentrations at sites from the networks listed above and others (e.g. National Core multi-pollutant monitoring (NCore; <https://www3.epa.gov/ttn/amtic/ncore.html>), Interagency

Monitoring of Protected Visual Environments (IMPROVE; <http://vista.cira.colostate.edu/Improve/>), Photochemical Assessment Monitoring Stations (PAMS)) that report concentrations to the U.S. EPA Air Quality System (AQS; <https://www.epa.gov/aqs>) and Canada's National Air Pollution Surveillance (NAPS; <https://www.canada.ca/en/environment-climate-change/services/air-pollution/monitoring-networks-data/national-air-pollution-program.html>) program.

Many of these monitoring networks were driven by efforts to control emissions from EGUs and thus trends in concentration are often compared with emissions. In the U.S., regulated EGU SO₂ and NO_x emissions are measured using hourly continuous emission monitors (CEM) and reported to EPA's Acid Rain Program (ARP) routinely. EPA Clean Air Markets Division (CAMD) maintains an archive of the EGU emissions and reports on trends in emissions and air quality (e.g., U.S. EPA, 2017). More broadly, quantification of long-term historic emissions is necessary to assess the impacts of emission control regulations on air pollutants and to help interpret measured changes in atmospheric chemistry and pollutant composition. Other non-EGU emissions are calculated based on mass balance techniques, e.g., fuel usage and fuel S content to estimate SO₂ emissions; fertilizer usage and herd size to estimate husbandry NH₃ emissions; traffic volume, mix and speed for vehicular NO_x emissions; or emission factors (U.S. EPA, 2018a). Emissions are a principal input to CTMs such as CMAQ (www.epa.gov/cmaq) that are used to simulate changes in air quality and deposition.

Dry deposition is typically assessed using a combination of measurements and model simulations although, in principle, deposition could be based solely on measurements. Wet deposition is measured at about 260 sites across U.S. in the NADP/NTN, however, there are no routine direct measurements of dry deposition due to the expense and complexity of the methods. Gradient flux data is available at a limited number of sites from results of co-located intensive studies (e.g. Rumsey and Walker, 2016). More information on direct dry deposition measurements and the prospective utility of the results in monitoring networks is discussed in **Section 3.1.1.1. Measurements of air-surface exchange of Nr in natural ecosystems across North America.**

Currently, total deposition is assessed in the U.S. using the NADP TDep method (Schwede and Lear, 2014), which combines concentration data from the ambient monitoring networks mentioned above and gridded concentrations from the CMAQ model. To estimate dry deposition, ambient concentration data from networks are merged with modeled concentrations, which are then combined with CMAQ modeled deposition velocities to calculate annual dry deposition fluxes. Gridded wet deposition flux estimates are derived from NADP/NTN measurements of concentration in precipitation and precipitation amounts and PRISM estimates of precipitation. The modeled PRISM grid of precipitation data based on terrain elevation, slope and aspect and climatic measurements is fused to create a modeled precipitation grid adjusted with the measured values and then combined with the measured pollutant concentrations in precipitation. The wet and dry annual deposition flux estimates are combined to obtain estimates of total deposition. TDep dry and wet deposition estimates are available for the period 2000 through 2016. Previously from 1990 through 2015, dry deposition estimates (Bowker et al., 2011) were made using Multilayer model (MLM; Meyers et al., 1998).

State of the science

Assessment of current monitoring trends in emissions and ambient concentration trends of SO₂, NO_y, and NH_x

Annual emissions reported by the U.S. EPA National Emissions Inventory (NEI; U.S. EPA, 2018b) averaged over three-year periods have decreased -83% for SO₂ and -53% for NO_x from 1990-1992 to 2014-2016 (Figure 1). A large portion of this decrease is from EGU emissions, which have reported reductions of -85% for SO₂ and -77% in NO_x during this period (U.S. EPA, 2018b). EGU emissions have been controlled at the stack or reduced due to market-driven switches to cleaner fuels (e.g. oil, natural gas).

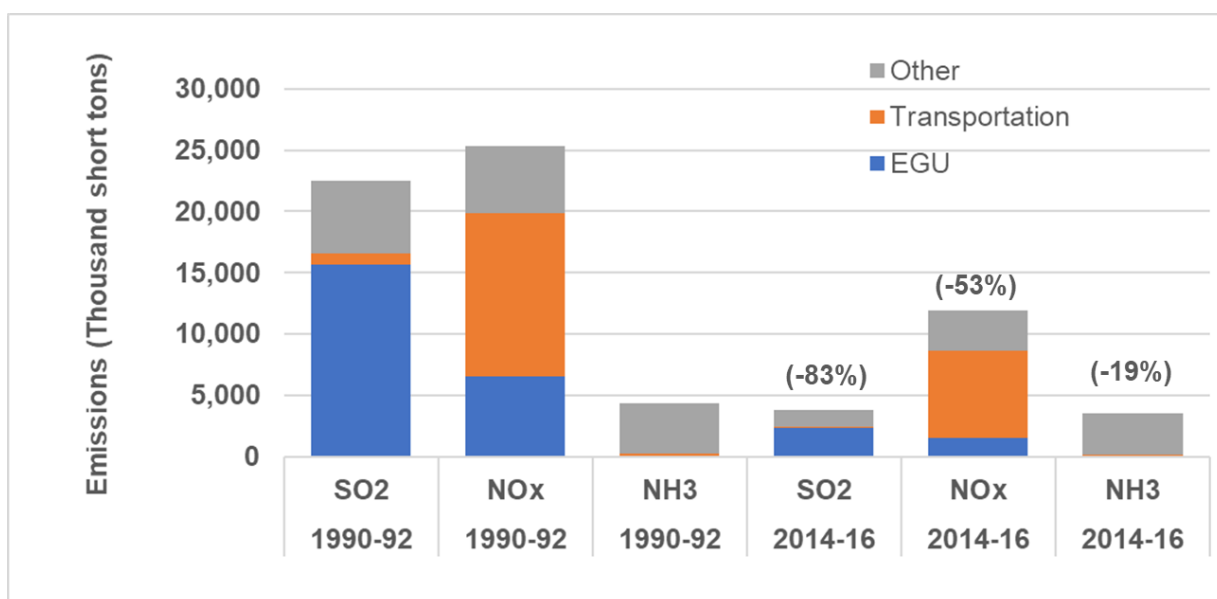
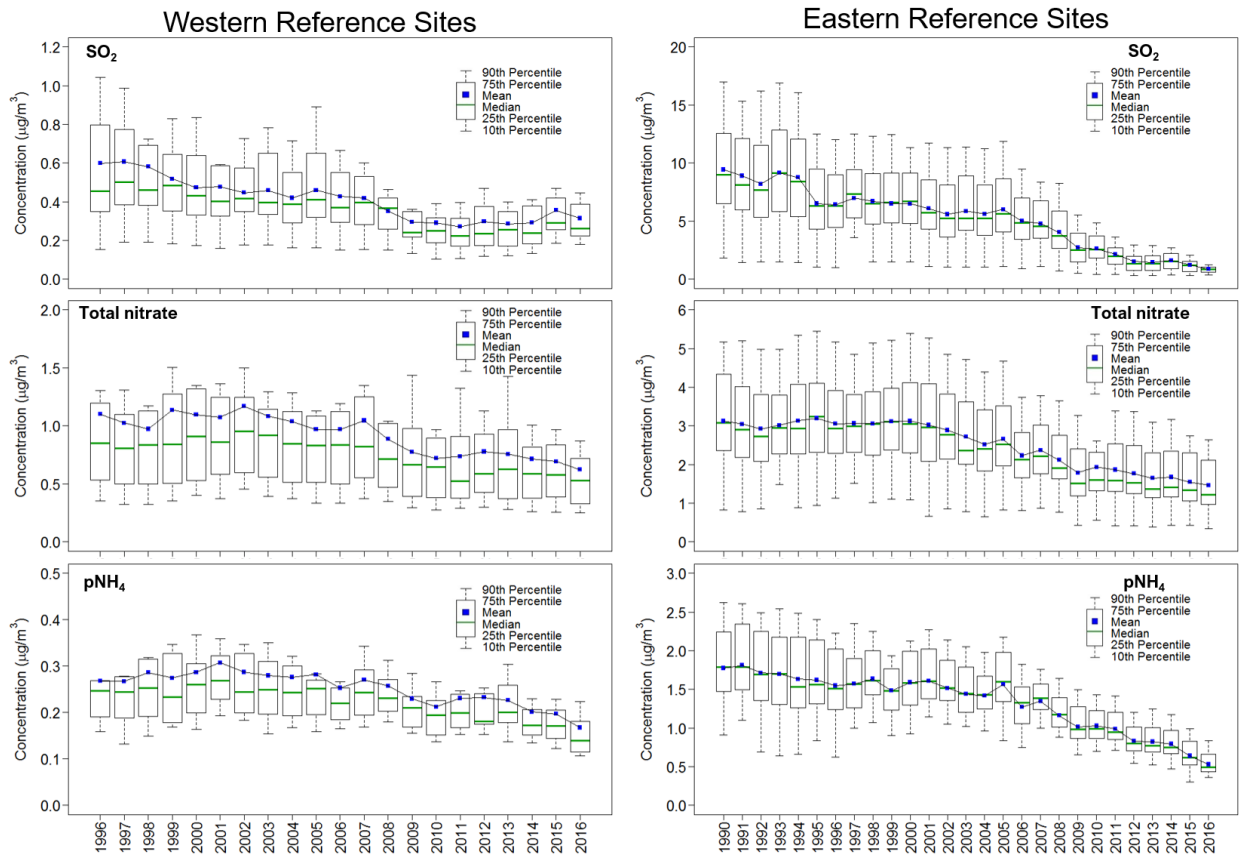

Figure 1. Three-year averaged annual NEI emission trends for SO₂, NO_x, and NH₃ categorized by source. Source categories are grouped as emissions from regulated EGUs, the transportation sector, and “other” which includes the remaining NEI sources including fuel combustion from non-EGU sources, industrial processes, agricultural sources, and events such as wildfires and prescribed burns. The percent decrease in overall emissions is noted above the 2014-16 bars.

These decreases in emissions are reflected in ambient measured concentrations and the relationship is especially evident for SO₂. The trend in annual mean SO₂ concentrations measured at CASTNET eastern reference sites (-86%; Figure 2) is approximately linearly related with the annual trend in aggregate SO₂ emissions from EGUs from eastern states (Figure 3; Wood Environment & Infrastructure Solutions, 2018b). These data demonstrate the use of monitored concentration and emission trends to track changes in emissions, concentrations

and deposition to allow gauging the effectiveness of national and regional air pollution control programs and provide accountability for regulators and the regulated community.



Source: Wood Environment & Infrastructure Solutions, 2018a

Figure 2. Trends in annual aggregate mean SO₂ (top), total nitrate (middle), and pNH₄ (bottom) concentrations from CASTNET eastern and western reference sites. The CASTNET reference sites are split into eastern and western regions due to the spatial density of the measurement sites, concentration differences, a difference in filterpack collection flowrate, and different start dates of operation.

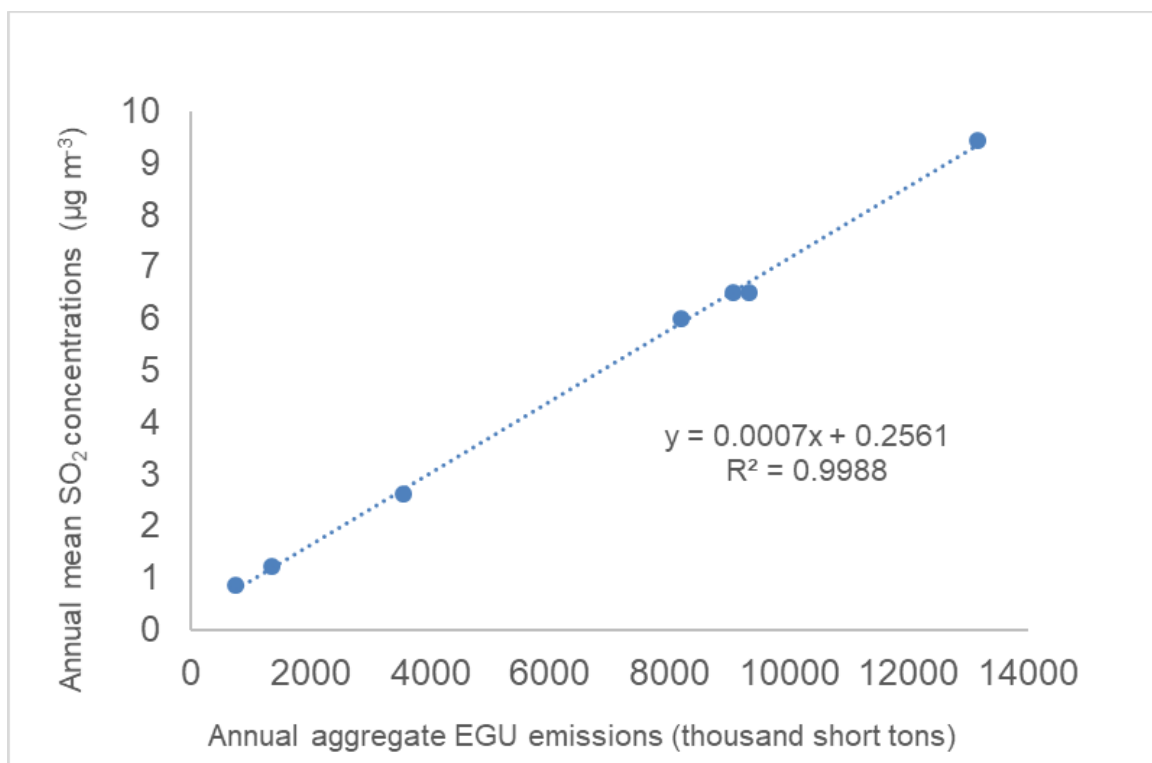

Figure 3. Comparison of annual mean SO₂ concentrations measured at eastern CASTNET reference sites vs. annual aggregate SO₂ emissions from eastern U.S. states

This relationship between EGU emissions and ambient concentrations is easier to discern for SO₂ than Nr species. The percentage of SO₂ emissions originating from EGUs was 69% in 1990, compared with 26% of total NO_x emissions originating from EGUs (U.S. EPA, 2018b). As of 2016, only 11% of total NO_x emissions are from EGUs, while 60% are associated with the transportation sector (U.S. EPA, 2018b). Both of these sectors have experienced decreases in NO_x emissions from 1990-1992 to 2014-2016, -77% for EGUs and -46% for transportation (U.S. EPA, 2018b). The trend in ambient concentrations of total nitrate [HNO₃ + pNO₃] monitored at eastern CASTNET reference sites declined by -48% from 1990-1992 to 2014-2016 (Figure 2). The decrease in ambient NO_x concentrations is consistent with the decreasing trends in NO_x emissions, but a definitive links in emissions and concentration trends are hard to quantify, due to uncertainties with the emissions inventory, especially for non-EGU sources.

As emissions and concentrations of NO_y have trended downward, the overall Nr budget has shifted towards a greater contribution from NH_x species (Li et al., 2016, Du et al., 2014). NH₃ emissions are reported to have decreased at a much slower rate (-19%) since 1990 (Figure 1; U.S. EPA, 2018b), with some studies reporting NH₃ emissions as near-level since 2001 (Butler et al., 2016; EPRI et al., 2015; Xing et al., 2013). Despite the fairly constant emission levels, ambient concentrations of pNH₄ have decreased -63% from 1990-1992 to 2014-2016, consistent with the decrease in pSO₄ (-71%) over the same time period. The concurrent decrease in pNH₄ and pSO₄ and near-level emissions of NH₃ suggest that less of the NH₃ is

partitioned to the particulate phase (i.e., ammonium sulfate $((\text{NH}_4)_2\text{SO}_4)$, ammonium bisulfate $(\text{NH}_4\text{HSO}_4)$, and ammonium nitrate (NH_4NO_3)) with less ambient acidic gases to react with (Butler et al., 2016). Ambient concentrations of NH_3 were not monitored at the national scale in the U.S. until the advent of the NADP/AMoN network in 2007. From 2008-2010 to 2014-2016, trends in pNH_4 decreased -39%, while NH_3 concentrations measured at 21 NADP/AMoN sites with long-term sampling records increased 24% (Figure 4). Summing the averages for pNH_4 and NH_3 for these two three-year periods and calculating the difference gives a rough NH_x trend of -4%, which is closer to the NEI NH_3 emissions trends during this time (-17%), but does not fully account for the discrepancy in the monitoring and emissions trends.

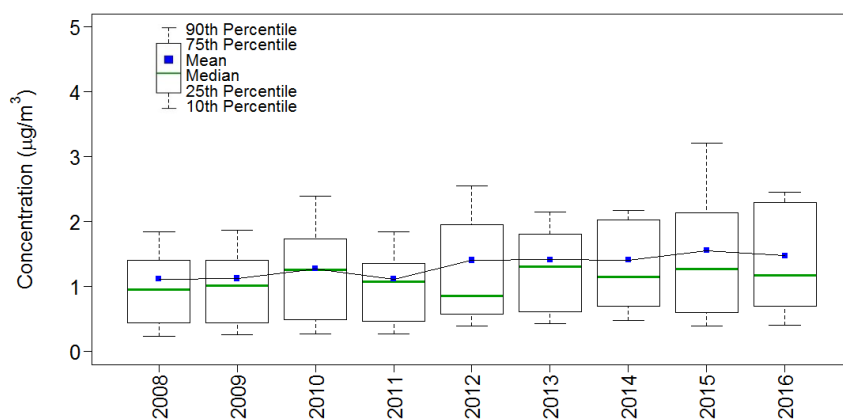

Figure 4. Trend in annual aggregate mean NH_3 concentrations from 21 NADP/AMoN sites from 2008 to 2016. The selected AMoN sites were chosen based on consistent operation over the entire time period, the AMoN network has increased include ~100 sites as of 2019.

An analysis by Butler et al., 2016 over a similar time frame and set of NADP/AMoN sites that statistically accounted for variability in the seasonality and regional location of the measurements suggests that increases in ambient NH_3 had a more moderate trend of $7 \pm 2\%$. This study demonstrates how the statistical approach to calculating trends from monitoring network data can influence the result, especially for a pollutant such as NH_3 , with high spatial and seasonal variability. Despite the uncertainty in the trends estimates, the consensus is that NH_3 levels are increasing and this observation has been supported with satellite measurements (Warner et al., 2017).

Linking the ambient concentration trends to emissions monitoring trends is difficult for NH_x , the uncertainties in the emissions inventory for Nr species are a significant knowledge gap and limitations to NH_3 monitoring (e.g. poor spatial resolution, sampling artifacts, poor interannual characterization of seasonal variance) make it difficult to characterize complicated chemistry and deposition mechanisms (Zhang et al., 2018; von Bobrozki et al., 2010; Bash et al., 2013).

Attempts to link trends in NH₃ emissions with monitored NH₃ concentrations were made in European studies evaluating the effects of NH₃ abatement policies (e.g. Gothenburg Protocol). Of the NH_x-species, gaseous NH₃ is the best to link from emissions to monitored concentration as NH₄⁺ is a secondary reaction product and is linked to changes in SO₄²⁻ or NO₃⁻ concentrations (Van Zanten et al., 2017). pNH₄ also has a considerably longer residence time in the atmosphere and thus measured concentrations will have a larger component transported from afar. The studies have been unsuccessful in determining a robust relationship between emissions and ambient concentrations and have found a divergence between expected NH₃ emissions reductions and either increases or steady levels in ambient monitoring of gaseous NH₃, wet NH₄⁺, and dry NH₄⁺. (Erisman et al., 1998; Erisman and Monteny, 1998; Sutton et al., 2003; Van Zanten et al., 2017). They hypothesize this “Ammonia Gap” is due either to unreported NH₃ emissions or that simultaneous decreases in SO₂ and NO_x have altered the amount of atmospheric processing that converts gaseous NH₃ into aerosol ammonium (Sutton et al., 2003; Van Zanten et al., 2017).

Phase-partitioning is an important factor to consider, as gaseous NH₃ has a deposition velocity 10 times that of particulate NH₄⁺ (Duyzer, 1994) and is similar to gaseous HNO₃. Thus, the particulate forms for both oxidized and reduced Nr species have a much longer lifetime that leads to increased transport and thus higher than expected atmospheric concentration levels and more regional dispersion. Several modeling studies, investigating the effect simulated NH₃ emissions reductions would have on PM_{2.5} concentrations, have offered hypotheses on the effects to Nr deposition, predicting that lowered particle pH would decrease overall NH_x deposition, but could increase localized (near-source) NO_y deposition as pNO₃ would partition to HNO₃ and deposit faster (Guo et al., 2018; Pinder et al., 2008). There also may be more indirect effects such as impacts to deposition pathways (e.g. cuticular resistance) that the decreased deposition of acidic species such as SO₂ may have on NH₃ deposition (Sutton et al., 2003). Trends in particle pH has not increased as hypothesized with the observed declines in acidic gases and level NH₃ concentrations (Weber et al., 2016). Studies on these trends and their effect on particle pH in the Southeastern portion of the study suggest factors such as organic films (Silvern et al., 2017) and the role of non-volatile cations (Guo et al., 2018) may complicate the chemistry.

Assessment of current monitoring trends in Nr deposition

The TDep method estimates total Nr deposition values based on measured ambient concentrations (dry) and measured concentrations in precipitation (wet) (Schwede and Lear, 2014), so trends in deposition should be reflective of concentration and emissions trends. TDep deposition estimates have been made from 2000 to present, though the available CMAQ model ‘run-years’ are limited to a ten-year series from 2002 to 2012. TDep modeling runs outside of this range use the most proximate CMAQ ‘run-year’ (i.e. TDep runs for 2001 and 2014 use the CMAQ ‘run-years’ 2002 and 2012, respectively). This is an obvious limitation and potential consequences of the discordant years is discussed in Section **3.2.4. Assessing uncertainty in total Nr deposition estimates for North American critical load applications**. A new CMAQ time-

series is planned as both an update to the CMAQ version and to expand the set of run-years to minimize the run-year mismatches and is further discussed in the Future Research section.

The comparison period used to evaluate trends in deposition is from 2000-2002 and 2014-2016. During this period, total (wet + dry) deposition of S has decreased -58% and for NO_y has decreased -35%, which are both consistent with, though less in magnitude, than the change in reported emissions and measured concentrations (Table 1).

Species	Time Period	Emissions	Concentrations	Total Deposition
SO ₂	1990-92 to 2014-16	-83	-86	-
	2000-02 to 2014-16	-76	-80	-58 ^o
NO _y	1990-92 to 2014-16	-53 ^ζ	-48 [¥]	-
	2000-02 to 2014-16	-48 ^ζ	-48 [¥]	-35
NH _x	1990-92 to 2014-16	-19 [†]	-63 [‡]	-
	2000-02 to 2014-16	-15 [†]	-58 [‡]	30
	2008-10 to 2014-16	-17 [†]	-39 [‡] ; 24 [‡] ; 7 ± 2 ^{†δ}	19

^o - reported as total S; ^ζ - reported as NO_x; [¥] - reported as total nitrate;
[†] - reported as NH₃; [‡] - reported as pNH₄⁺; ^δ - Butler et al., 2016

Table 1. Summary of percent differences for SO₂, NO_y, and NH_x in emissions, concentrations, and total deposition over different time periods of comparison. All percent differences are obtained from three-year averages at the beginning and end of the time period as indicated.

For NH_x, the trend in total deposition has increased 30% over the same time period. Figure 5 shows the TDep estimated trends in deposition categorized by component. Overall, total Nr deposition has decreased -13%, and as of 2013, the estimated contributions from NH_x and NO_y are essentially equivalent (Figure 5). This is consistent with other studies which have also documented the increased contribution from NH_x to the total Nr deposition budget (Li et al., 2016; Du et al., 2014). The increase in NH_x is mostly due to a 24% in wet deposition of NH₄⁺ and a 54% increase in dry NH₃ deposition. These two processes account for 30% and 18% of the 2014-2016 total Nr deposition budget. Dry deposition of pNH₄ decreased -17%, a trend consistent with the declining trend in ambient pNH₄, but that process only represents 2% of the deposition budget and is indicative of the importance of phase-partitioning of the NH_x species to the Nr deposition budget. The increase in NH₄⁺ wet deposition is thus likely due to the entrainment of ambient NH₃ in precipitation rather than washout of pNH₄ (Butler et al., 2016). The increased presence of NH₃ would appear have the effect of decreased NH_x transport and increased local deposition (Pinder et al., 2008, Butler et al., 2016), but some considerations such as the bidirectionality of NH₃ deposition (Bash et al., 2013) can complicate the process and more study is needed.

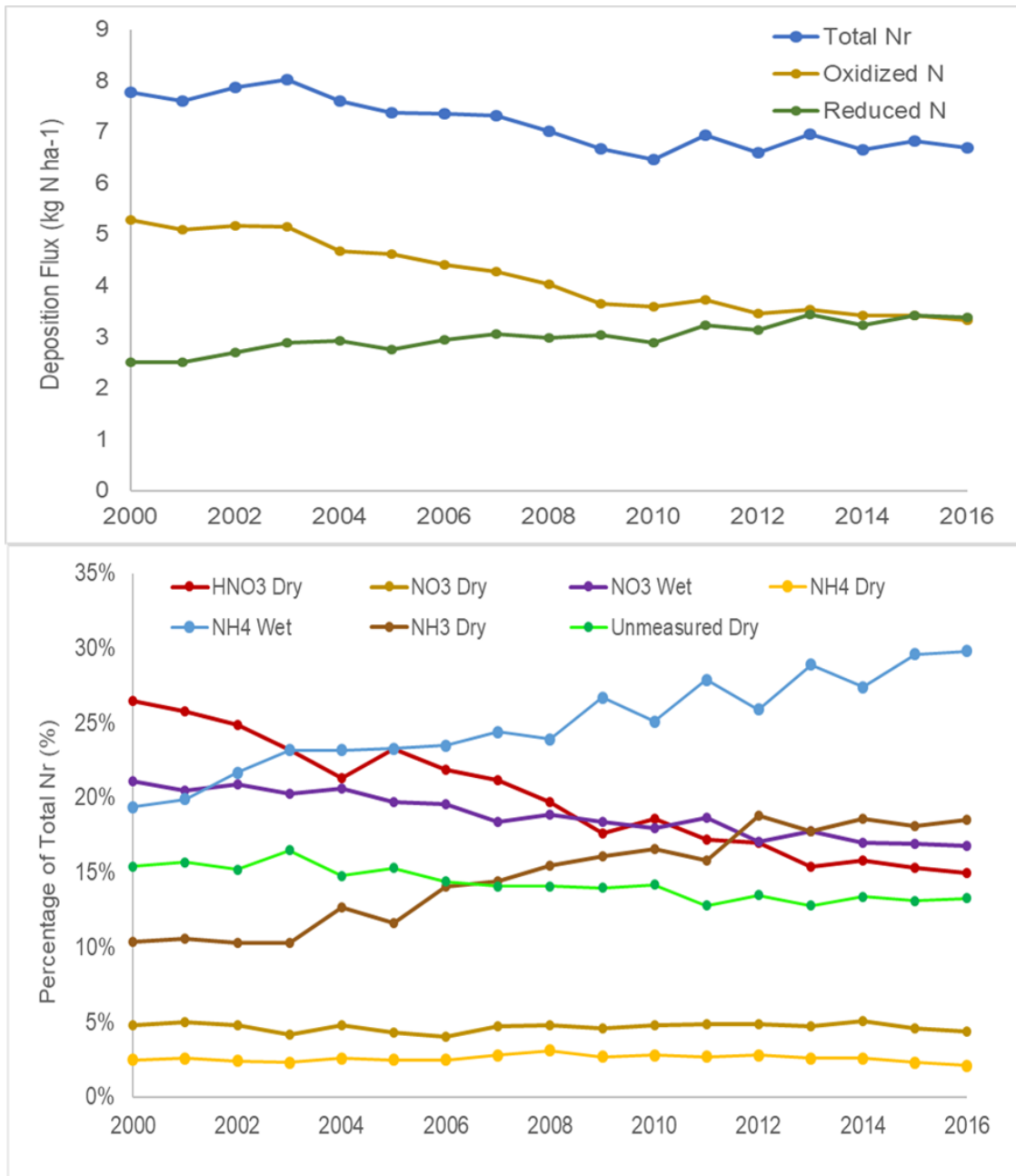
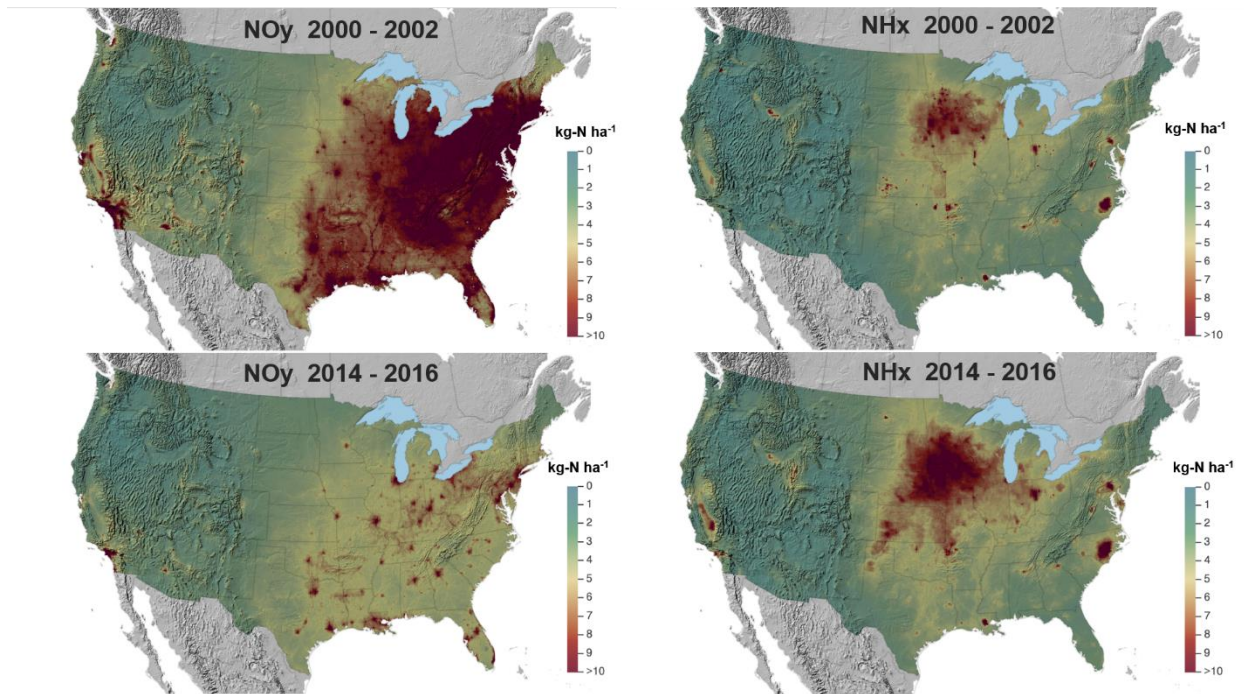

Figure 5. Trends in Nr deposition output by the TDep measurement-model fusion method. Top plot is the deposition flux of total Nr and its oxidized and reduced components (kg-N ha⁻¹). The lower plot is the percentage of total Nr deposition for each modeled species and its deposition pathway (i.e. dry or wet).

The TDep maps show the shift in the Nr deposition budget over the contiguous U.S. from predominately oxidized to a split between NO_y and NH_x (Figure 6). The largest decreases in NO_y are concentrated in the eastern portion of the U.S. with a high population of EGUs and significant NO_x reductions since 1995 (Figure 7). Hotspots of NO_y deposition are now centered

in urban areas. Increases in NH_x deposition are observable in major agricultural centers including the midwestern states, eastern NC, and in southeastern PA (Figure 5).



Source: NADP, 2019

Figure 6. Deposition maps of NO_y and NH_x from 2000-2002 to 2014-2016.

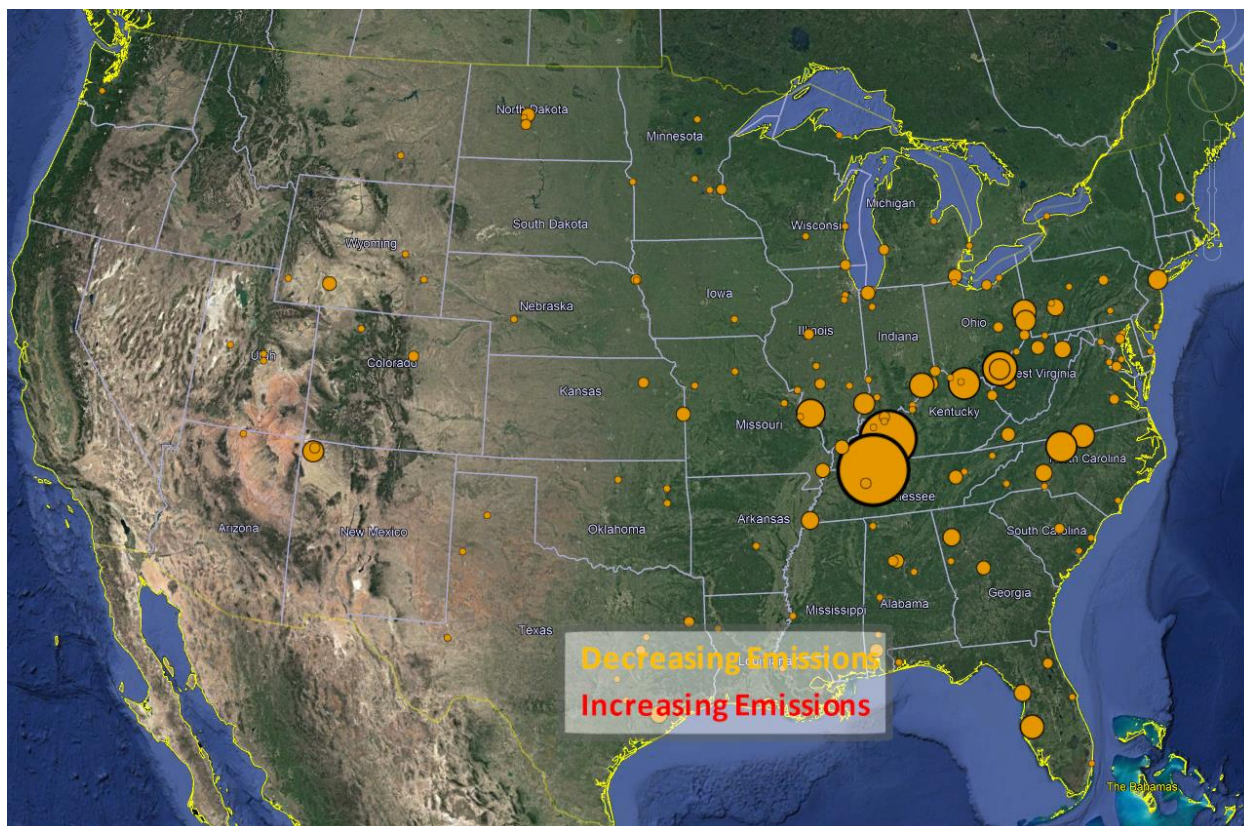

Source: U.S. EPA, 2019

Figure 7. Annual Nitrogen Oxides Emissions Changes, 1995-2018. Reductions are represented by orange circles and increases in red circles. For reference, the largest decrease is -170 thousand tons of NO_x in northwestern TN.

Use of remote sensing methods to supplement monitoring of emissions, concentrations, and deposition

The burgeoning technology of remote sensing of near-surface atmospheric concentrations of optically active trace gases has advanced to provide long-term emissions and concentration monitoring trends of NO₂ and NH₃ (e.g. Martin et al., 2003; Lamsal et al., 2008; Nowlan et al., 2014; Lamsal et al., 2015; Warner et al., 2017). This is discussed in more detail in Section **3.1.2.2. Satellite measurements of oxidized and reduced nitrogen for application to Nr budgets.**

These remotely detected monitoring trends have been compared with long-term surface monitoring trends for both emissions (Lamsal et al., 2011; Duncan et al., 2013) and surface concentrations to assess accuracy and variability of those measurements on both regional and global scales (Nowlan et al., 2014; Schiferl et al., 2016). The datasets have been used to evaluate emission inventories (Lamsal et al., 2011; Tong et al., 2015) and to characterize limitations in current monitoring and modeling capabilities (Pinder et al., 2011; Zhu et al., 2013;

Lonsdale et al., 2015). Several studies have used remotely sensed concentration measurements and combined them with CTM-output and deposition flux models to measure trends in Nr deposition (Cheng et al., 2013; Lu et al., 2013; Nowlan et al., 2014; Geddes and Martin, 2017; Kharol et al., 2018). These datasets provide information on spatial variability that can complement surface monitoring data and help to characterize the spatial representativeness of a measurement at a point location.

Future research

The long-term Nr trends discussed in the ‘State of the Science’ section have some significant uncertainties owing to limitations in emission inventories, the spatial and temporal coverage of available long-term monitoring data, and the high chemical reactivity and complex deposition pathways of Nr species that are not yet well-represented in chemical transport models (CTMs).

As demonstrated by Butler et al., 2016, spatial and seasonal variance can influence calculated trends. Monitoring networks could review reported annual trends and apply more robust statistical techniques to improve monitoring trends and relationships to emissions and better characterize response to local pollution controls. Studies evaluating the efficacy of national abatement strategies in Europe should be considered. A review such as this could be conducted by one of the national monitoring networks (e.g. CASTNET, NADP) in conjunction with a network evaluation and consideration of future strategies and could be a near-term effort.

Limitations to the emissions inventories and modeling of emissions

On the emissions side, more robust inventories for non-EGU sources are needed, especially for NH_x and organic nitrogen (ON) species. This is a knowledge gap that has been identified in many other sections in this White Paper for NH_x sources, including emission potentials from soil and vegetative sources, for ON emissions, and non-EGU emission sources (see Sections **3.4.2. Spatial variability of ammonia in agricultural regions**; **3.2.3. Modeling fluxes of Nr using chemical transport models**; **3.1.2.5. Characterization of organic nitrogen in air and precipitation**; **3.2.1. Application of a bidirectional ammonia air-surface exchange model at NADP AMoN sites**).

Because non-EGU emissions are not typically measured, there are usually greater uncertainties associated with them, because they are calculated based on mass-balance techniques (U.S. EPA, 2018a). Emissions from these sources tend to be much more variable with time or even episodic (e.g. plume release, or emissions from a specific process). This is particularly true for mobile sources such as vehicular NO_x emissions which will vary with traffic volume, fleet mix, speed, and location. Studies have suggested that NEI mobile source NO_x emissions are overestimated, particularly in the summer (McDonald et al., 2012; Anderson et al., 2014; McDonald et al., 2018).

For NH_x , NEI estimates that 80% of U.S. NH_3 emissions are associated with commercial crop and livestock production (U.S. EPA, 2018b; Vitousek et al., 1997; Aneja et al., 2009; Battye et al., 2003). NH_3 emissions originating from soils that receive commercial N fertilization account for from 15 to 30% of all agricultural NH_3 emissions (U.S. EPA, 2018b, Aneja et al., 2009; and Battye et al., 2003). NH_3 emissions are difficult to model because they depend on agricultural practices (e.g., herd size and location) that are poorly characterized in emissions inventory development (McQuilling and Adams, 2015). Wildfires and prescribed burns also produce significant NH_3 emissions (Crutzen and Andreae, 1990; Bouwman et al., 1997) and are poorly characterized in emissions databases. The USDA Environmental Policy Integrated Climate (EPIC) agrosystem model has resulted in improved estimates of NH_3 emissions associated with crop fertilization, and EPA is currently working on improving estimates of NEI NH_3 emissions for livestock operations and is considering implementing the emission model developed by McQuilling et al. (2015) as part of NEI. McQuilling and her colleagues (2015) modified a farm emissions model (FEM) based on data reported in the literature for beef, swine and poultry production developed previously for dairy production; they then evaluated this data using emissions factors from literature and those from the EPA National Air Emissions Monitoring Study (NAEMS). It is important that emissions from animal feeding be resolved at the facility scale. The development of this emissions inventory is a long-term goal that will require collaboration from industry stakeholders, USDA and other federal agencies, and academic institutions. In urban areas, emissions of NH_3 from mobile sources may be significant and are likely underestimated in current inventories (Fenn et al., 2018; Sun et al., 2017).

Limitations in monitoring and deposition trends

Limitations also exist in the available N_r monitoring data and how those measurements are used to assess total N_r deposition. Current national monitoring networks need to consider new strategies to expand sampling protocols to address the lack of spatially and temporally resolved measurements of N_r species significant to the deposition budget. Particularly, expansion of existing infrastructure to include bulk measurements of ON in both precipitation and by filter collection is needed. There are some key obstacles to overcome (e.g. low concentrations and sample instability), but sampling protocols may be implemented to ameliorate some of these artifacts (e.g. refrigeration of samples, chemical conversion to more stable analytes). A detailed discussion is included in Section **3.1.2.5. Characterization of organic nitrogen in air and precipitation**. This effort would likely be a long-term effort and could be pursued by federal agencies that support the monitoring networks and driven by steering committees of subcommittees associated with those networks (e.g. NADP Network Operations Subcommittee).

The NADP AMoN network has been measuring biweekly concentrations of NH_3 with passive samplers since 2007. This has been integral in expanding understanding of the spatial and temporal variability of NH_3 and of NH_x as a whole. There are still gaps in the spatial variability of NH_3 particularly near agricultural emissions sources and these are discussed in detail in Section **3.4.2. Spatial variability of ammonia in agricultural regions**. Similarly, ambient monitoring of urban and coastal areas are currently limited. The expansion of low-cost passive sampler sites such as those maintained by the NADP AMoN network to these areas could be a near-term

effort. The addition of passive NO₂ samplers to urban locations could be a good strategy to develop in-situ correlations of passive methods with some of the high-resolution active sampling of NO_x reported in the EPA AQS database. This would also be a good strategy to expand NO₂ measurements into rural areas (most AQS monitors are in high population areas) to obtain more regionally representative concentrations. Satellite measurements could be used to help identify new monitoring locations and to better understand measurement spatial representativeness and what factors could potentially affect this.

The TDep methodology currently does not use measurements to adjust CMAQ-modeled deposition for NH₃ or NO₂. Ambient NH₃ concentrations have a non-linear relationship with modeled bi-directional deposition velocities that currently prevent its inclusion. Research is currently underway to modify the TDep methodology to utilize this concentration data and is a near-term goal. NO₂ included in the set of CMAQ-modeled 'unmeasured' components that currently make up ~13% of the total Nr deposition budget (Figure 5). Those components also include nitrous acid (HONO), dinitrogen pentoxide (N₂O₅), NO, organic nitrate, peroxyacyl nitrate (PAN), aromatic PANs (OPAN) and C3 and higher PANs (PAN_x).

Despite a small deposition velocity, NO₂ contributes significantly to the Nr deposition budget (Zhang et al., 2009), and many North American deposition networks do not include this measurement since it requires active sampling of the gaseous species. As noted earlier, NO and NO₂ measurements exist throughout the U.S. (~390 sites reporting to U.S. EPA AQS) and Canada (~160 sites reporting to NAPS). These measurements are utilized for ECCC's ADAGIO measurement-model fusion deposition model; utilization in the TDep MMF methodology is needed. Additionally, EPA has developed an enhanced Nr speciation analyzer, Nitrotrain, that provides hourly speciated measurements of oxidized and reduced Nr.

Network efforts to expand spatial coverage of ambient concentrations could include remote sensing datasets. While the Nr species suite is limited to NH₃ and NO₂ and comparisons with surface measurements are not direct (remote sensing data can only determine aloft concentrations in the lower troposphere), the spatial coverage from remote sensing techniques cannot be replicated by surface monitoring. Studies would be designed to establish correlations between remote sensing data and surface monitors in these locations to further investigate spatial and temporal variability of NH₃ and NO₂.

Establishment of low-cost direct deposition measurements within existing monitoring network infrastructure is needed. An example technology is described in detail in Section **3.1.2.4. Low-cost method for routine monitoring of air-surface exchange of Nr compounds**. These measurements could be directly used to inform deposition models and evaluate potential biases.

Maintaining consistency in deposition trends with modeling improvements

Wet deposition is easier to estimate using monitoring approaches available in U.S. monitoring networks but the methods to estimate dry deposition using measured ambient concentrations are still evolving. There have been many improvements in understanding deposition processes

and deposition velocities and newer methods of dry deposition estimation using modules within CTM are more accurate than traditional methods (e.g. Multi-Layer Model; Meyers et al., 1998) used by monitoring networks only a few years removed (Wu et al., 2018). These improvements are necessary and advance the science, but can cause artifacts in modeled deposition estimates which manifest as time-series step functions when evaluating long-term datasets. A near-term knowledge gap is to compare and reconcile newer deposition mapping methodologies (e.g. TDep method) with older deposition techniques (e.g. MLM) in overlapping years to evaluate past trends for improved deposition trends. An example of this comparison is shown in Figure 8. Here, the overlapping TDep and MLM trends in total Nr deposition have been calculated for the period 2000 through 2014 for both eastern and western reference sites in CASTNET. The TDep deposition estimates are about twice as high as MLM estimates, yet the relative trends between the two modeling methods are very similar and exhibit no biases (Wood Environment & Infrastructure Solutions, 2017). This information can be used to extrapolate TDep deposition estimates back to 1990 as a number of significant emissions reductions took place during this period.

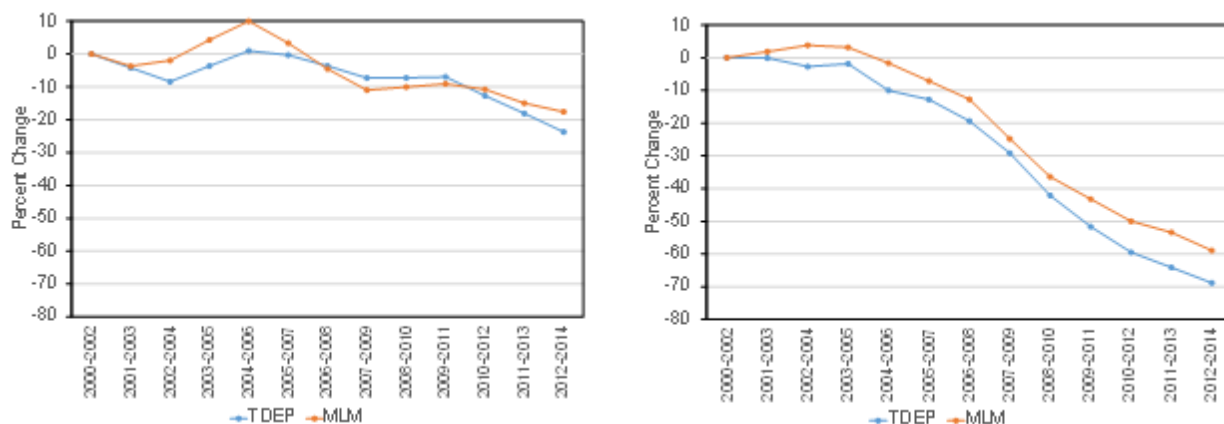

Figure 8. Percent Change in 3-year Mean TDep and MLM total deposition of nitrogen at western (left) and eastern (right) CASTNET Reference Sites

As described in the introduction, the TDep mapping method uses CMAQ-predicted deposition velocities and concentrations from version 5.0.2. CMAQ is routinely updated as scientific information is improved. For example, version 5.1 is major update to CMAQ that includes several changes to the science algorithms in the base model, including improvements to chemistry, transport, and air-surface exchanges.

Particularly relevant to this discussion are the improvements to simulate bidirectional surface exchange processes and the coupling with the USDA EPIC agroecosystem model (Cooter et al., 2012; Bash et al., 2013). Version 5.1 includes an improved dry deposition model for ON compounds. Further improvements to CMAQ will be made as scientific understanding of atmospheric deposition processes improves, e.g., from routine monitoring of air-surface

exchange of Nr compounds. Existing measurements from routine monitoring networks have been used to evaluate biases in deposition models in the past and would continue to be used in that regard.

CMAQ version 5.3 is under development and is expected to be released in the summer of 2019. Results from this improved version were compared to 2002 CMAQ simulations without bidirectional processes. The CMAQ-EPIC coupled system reduced the bias in the model simulations versus measured deposition and consequently improved the modeling of NH_x wet deposition and pNO_3^- dry deposition, especially during the spring and fall seasons. Along these lines, newer methods of estimating dry deposition are currently being improved on several fronts (e.g. impacts of land-use types, impacts of bidirectional air-surface exchange, improvement in spatial and temporal resolutions of monitoring data for an expanded suite of Nr compounds). There are several sections within this White paper document that focus in more detail on these topics (specifically Sections **3.1.1.1. Measurements of air-surface exchange of Nr in natural ecosystems across North America**, **3.2.1. Application of a bidirectional ammonia air-surface exchange model at NADP AMoN sites**, **3.2.3. Modeling fluxes of Nr using chemical transport models**, **3.2.4. Assessing uncertainty in total Nr deposition estimates for North American critical load applications**, **3.4.2. Spatial variability of ammonia in agricultural regions**). While they are certainly relevant to the field of evaluating monitoring trends, they will not be discussed at length in this section.

The current TDep maps use CMAQ version 5.0.2 runs for the years 2002-2012. For 2013-2017, TDep used the CMAQ 2012 runs combined with year-specific observational data. New CMAQ simulations for 2015 will be run in the fall of 2019 using version 5.3, which includes updates to dry deposition, a new chemical mechanism (CB6r3), NO_y updates (new ON species) and other improvements. The implementation of any CMAQ updates makes it difficult to compare year-to-year deposition fluxes and estimate trends in deposition. To maintain consistent and scientifically up-to-date deposition trends, adjustment factors must be applied to historic deposition estimates. A gridded bias correction surface for CMAQ was produced in order to characterize and correct any biases that arise due to model enhancements or changes from model version to version. This product is described in more detail in Section **3.2.4. Assessing uncertainty in total Nr deposition estimates for North American critical load applications**. This gridded bias surface correction will be a product to accompany any future CMAQ version releases in order to keep deposition trends consistent and reflective of the current science.

References

Anderson, D.C., Loughner, C.P., Diskin, G., Weinheimer, A., Canty, T.P., Salawitch, R.J., Worden, H.M., Fried, A., Mikoviny, T., Wisthaler, A., Dickerson, R.R. 2014. Measured and modeled CO and NO_y in DISCOVER-AQ: An evaluation of emissions and chemistry over the eastern US. *Atmospheric Environment* 96, 78-87.

Aneja, V.P., Schlesinger, W.H., Erisman, J.W. 2009 Effects of agriculture upon the air quality and climate: research, policy and regulations. *Environmental Science and Technology*, 43, 4234-4240.

Bash, J.O., Cooter, E.J., Dennis, R.L., Walker, J.T. Pleim, J.E. 2013. Evaluation of a regional air-quality model with bidirectional NH₃ exchange coupled to an agroecosystem model. *Biogeosciences*, 10, 1635–1645.

Battye, W., Aneja, V.P., and Roelle. P.A. 2003. Evaluation and improvement of ammonia emissions inventories. *Atmospheric Environment* 37, 3873–3883.

Bobbink, R., Hicks, K., Galloway, J., Spranger, T., Alkemade, R., Ashmore, M., Bustamante, M., Cinderby, S., Davidson, E., Dentener, F., Emmett, B., Erisman, J.W., Fenn, M., Gilliam, F., Nordin, A., Pardo, L., de Vries, W. 2010. Global Assessment of Nitrogen Deposition Effects on Terrestrial Plant Diversity: a synthesis. *Ecological Applications*, 20 (1), 30–59.

Bouwman, A.F., Lee, D.S., Asman, W.A.H., Dentener, F.J., Van Der Hoek, K.W., Olivier, J.G.J. 1997. A global high-resolution emission inventory for ammonia. *Glob. Biogeochem. Cy.* 11, 561-587.

Bowker, G.E., Schwede, D.B., Lear, G.G., Warren-Hicks, W.J., Finkelstein, P.L. 2011. Quality Assurance Decisions with Air Models: A Case Study of Imputation of Missing Input Data Using EPA's Multi-Layer Model. *Water, Air, & Soil Pollution* 223, 391-402. doi: 10.1007/s11270-011-0832-7.

Butler, T., Vermeylen, F., Lehmann, C.M., Likens, G.E., Puchalski, M. 2016. Increasing ammonia concentration trends in large regions of the U.S.A derived from the NADP/AMoN network. *Atmospheric Environment* 146, 132-140. <https://doi.org/10.1016/j.atmosenv.2016.06.033>.

Cheng, M., Jiang, H., Guo, Z., Zhang, X., Lu, X. 2013. Estimating NO₂ dry deposition using satellite data in eastern China, *Int. J. Remote Sens.*, 34: 2548–2565, <https://doi.org/10.1080/01431161.2012.747019>.

Cooter, E.J., Bash, J.O., Benson, V. Tan, L. 2012. Linking agricultural crop management and air quality models for regional to national-scale nitrogen assessments. *Biogeosciences*, 9, 4023–4035.

Crutzen, P.J., Andreae, M.O. 1990. Biomass burning in the tropics: impact on atmospheric chemistry and biogeochemical cycles. *Science* 250, 1669-1678. <http://dx.doi.org/10.1126/science.250.4988.1669>.

Du, E., de Vries, W., Galloway, J.N., Hu, X. and Fang, J. 2014. Changes in wet nitrogen deposition in the United States between 1985 and 2012. *Environ. Res. Lett.* 9, 095004 (8pp), doi:10.1088/1748-9326/9/9/095004.

Electric Power Research Institute, EPRI. 2015. Long-term Emissions and Air Quality Trends in the United States. <https://www.epri.com/#/pages/product/3002005240/>. Accessed March 2019.

Erisman, J.W., Bleeker, A., van Jaarsveld, J.A. 1998. Evaluation of ammonia emission abatement on the basis of measurements and model calculations. *Environ. Pollut.*, 102, 269-274.

Erisman, J.W., Monteny, G.J. 1998. Consequences of new scientific findings for future abatement of ammonia emissions. *Environ. Poll.*, 102 (special issue), 275-282.

Fenn M.E, Bytnerowicz, A., Schilling, S.L., Vallanob, D.M., Zavaleta, E.S., Weiss, S.B., Morozumi, C., Geiser, L.H., and Hanks, K. 2018. On-road emissions of ammonia: An underappreciated source of atmospheric nitrogen deposition. *Sci. Total Environ.* 625, 909–919.

Geddes, J.A., Martin, R.V. 2017. Global deposition of total reactive nitrogen oxides from 1996 to 2014 constrained with satellite observations of NO₂ columns. *Atmos. Chem. Phys.* 17,10071-10091. <https://doi.org/10.5194/acp-17-10071-2017>.

Kharol, S.K., Shephard, M.W., McLinden, C.A., Zhang, L., Sioris, C.E., O'Brien, J.M., Vet, R., Cady-Pereira, K.E., Hare, E., Siemons, J., Krotkov, N.A. 2018. Dry Deposition of Reactive Nitrogen From Satellite Observations of Ammonia and Nitrogen Dioxide Over North America. *Geophys. Res. Lett.* 45, 1157-1166. <https://doi.org/10.1002/2017GL075832>.

Guo, H., Otjes, R., Schalg, P., Kiendler-Scharr, A., Nenes, A., Weber, R.J. 2018. Effectiveness of ammonia reduction on control of fine particle nitrate. *Atmos. Chem. Phys.* 18, 12241-12256. <https://doi.org/10.5194/acp-18-12241-2018>.

Lamsal, L.N., Martin, R.V., van Donkelaar, A., Steinbacher, M., Celarier, E.A., Bucsela, E., Dunlea, E.J., Pinto, J.P. 2008. Ground-level nitrogen dioxide concentrations inferred from the satellite-borne Ozone Monitoring Instrument. *Journal of Geophysical Research* 113, D16308.

Lamsal, L.N., Martin, R.V., Padmanabhan, A., van Donkelaar, A., Zhang, Q., Sioris, C.E., Chance, K., Kurosu, T.P., Newchurch, M.J. 2011. Application of satellite observations for timely updates to global anthropogenic NO_x emission inventories. *Geophysical Research Letters* 28, L05810.

Lamsal L.N., Duncan, B.N., Yoshida, Y., Krotkov, N.A., Pickering, K.A., Streets, D.G., Lu, Z. 2015. U.S. NO₂ trends (2005-2013): EPA Air Quality System (AQS) data versus improved observations from the Ozone Monitoring Instrument (OMI). *Atmos. Environ.* 110: 130-145. <https://doi.org/10.1016/j.atmosenv.2015.03.055>.

Li, Y., Schichtel, B.A., Walker, J.T., Schwede, D.B., Chen, X., Lehmann, M.B., Puchalski, M.A., Gay, D.A., Collett, J.L. 2016. Increasing Importance of Deposition of Reduced Nitrogen in the United States. www.pnas.org/lookup/suppl/doi:10.1073/pnas.1525736113/-/DCSupplemental.

Lonsdale, C. R., Hegarty, J. D., Cady-Pereira, K. E., Alvarado, M. J., Henze, D. K., Turner, M. D., Capps, S. L., Nowak, J. B., Neuman, J. A., Middlebrook, A. M., Bahreini, R., Murphy, J. G., Markovic, M. Z., VandenBoer, T. C., Russell, L. M., Scarino, A. J. 2017. Modeling the diurnal variability of agricultural ammonia in Bakersfield, California, during the CalNex campaign, *Atmos. Chem. Phys.*, 17, 2721–2739, <https://doi.org/10.5194/acp-17-2721-2017>.

Lu, X., Jiang, H. Zhang, X., Liu, J. Zhang, Z., Jin, J., Wang, Y, Xu, J., Cheng, M. 2013. Estimated global nitrogen deposition using NO₂ column density. *Int. J. of Remote Sensing*. 34 (24), 8893-8906. <https://doi.org/10.1080/01431161.2013.853894>.

Martin, R.V., Jacob, D.J., Chance, K., Kurosu, T.P., Palmer, P.I., Evans, M.J. 2003. Global inventory of nitrogen oxide emissions constrained by space-based observations of NO₂ columns. *J. Geophys. Res.* 108, 4537. doi:10.1029/2003JD003453.

McDonald, B.C., Dallmann, T.R., Martin, E.W., Harley, R.A. 2012. Long-term trends in nitrogen oxide emissions from motor vehicles at national, state, and air basin scales. *Journal of Geophysical Research: Atmospheres* 117, D00V18. doi:10.1029/2012JD018304.

McDonald, B.C., McKeen, S.A., Cui, Y.Y., Ahmadov, R., Kim, S.-W., Frost, G.J., Pollack, I.B., Peischl, J., Ryerson, T.B., Holloway, J.S., Graus, M., Warneke, C., Gilman, J.B., de Gouw, J.A., Kaiser, J., Keutsch, F.N., Hanisco, T.F., Wolfe, G.M., Trainer, M. 2018. Modeling Ozone in the Eastern U.S. using a Fuel-Based Mobile Source Emissions Inventory. *Environmental Science & Technology* 52, 7360-7370.

McQuilling, A. Adams, P. 2015. Extended Abstract: Modeling livestock Ammonia Emissions in the United States: from Farms to Emissions to Particulate Matter. EPA 2015 International Emission Inventory Conference. <https://www.epa.gov/air-emissions-inventories/2015-international-emission-inventory-conference-air-quality-challenges>.

Meyers, T.P., Finkelstein, P., Clarke, J., Ellestad, T.G., Sims, P.F. 1998. A multilayer model for inferring dry deposition using standard meteorological measurements. *J. Geophys. Res.*, 103, D17, 22645-22661. <https://doi.org/10.1029/98JD01564>.

National Atmospheric Deposition Program. 2019. TDep Annual Reports. <http://nadp.slh.wisc.edu/committees/tdep/reports/>. Accessed March 2019.

Nowlan, C. R., Martin, R. V., Philip, S., Lamsal, L. N., Krotkov, N. A., Marais, E. A., Wang, S., Zhang, Q. 2014. Global dry deposition of nitrogen dioxide and sulfur dioxide inferred from space-based measurements. *Global Biogeochem. Cycles*, 28, 1025–1043. <https://doi.org/10.1002/2014GB004805>

Pinder, R. W., Gilliland, A. B., Dennis, R. L. 2008. Environmental impact of atmospheric NH₃ emissions under present and future conditions in the eastern United States. *Geophys. Res. Lett.*, 35: L12808. <https://doi.org/10.1029/2008gl033732>.

Pinder, R.W., Walker, J.T., Bash, J.O., Cady-Pereira, K.E., Henze, D.K., Luo, M., Osterman, G.B., Shephard, M.W., 2011. Quantifying spatial and seasonal variability in atmospheric ammonia with in situ and space-based observations. *Geophys. Res. Lett.* 38 (4). <http://dx.doi.org/10.1029/2010GL046146>.

Rumsey, I.C. Walker, J.T. 2016. Application of an online ion-chromatography-based instrument for gradient flux measurements of speciated nitrogen and sulfur. *Atmos. Meas. Tech.*, 9, 2581–2592.

Schiferl, L.D., Heald, C.L., Van Damme, M., Clarisse, L., Clerbaux, C., Coheur, P., Nowak, J.B., Neuman, J.A., Herndon, S.C., Roscioli, J.R., Eilerman, S.J. 2016. Interannual Variability of Ammonia Concentrations over the United States: Sources and Implications. *Atmos. Chem. Phys.*, 16, 1230-12328. <https://doi.org/10.5194/acp-16-12305-2016>.

Schwede, D.B. and Lear, G.G. 2014. A Novel Hybrid Approach for Estimating Total Deposition in the United States. *Atmos. Environ.*, 92:207-220. doi: 10.1016/j.atmosenv.2014.04.008.

Silvern. R.F., Jacob, D.J., Kim, P.S., Marais, E.A., Turner, J.R., Campuzano-Jost, P., Jimenez, J.L. 2017. Inconsistency of ammonium-sulfate aerosol ratios with thermodynamic models in the eastern US: a possible role of organic aerosol. *Atmos. Chem. Phys.*, 17: 5107-5118. <https://www.atmos-chem-phys.net/17/5107/2017/>.

Sun, K., Tao, L., Miller, D.J., Pan, D., Golston, L.M., Zondlo, M.A., Griffin, R.J., Wallace, H.W., Leong, Y.J., Yang, M.M., Zhang, Y., Mauzerall, D.L., Zhu, T., 2017. Vehicle emissions as an important urban ammonia source in the United States and China. *Envi. Sci. Technol.*, 51, 2472-2481.

Sutton, M.A., Asman, W.A.H., Ellerman, T., van Jaarsveld, J.A., Acker, K., Aneja, V., Duyzer, J., Horvath, L., Paramonov, S., Mitosinkova, M., Tang, Y.S., Achermann, B., Gauger, T., Bartniki, J., Neftel, A., Erisman, J.W. 2003. Establishing the link between ammonia emission control and measurements of reduced nitrogen concentrations and deposition. *Environ. Monit. Assess.* 82, 149-185.

Tong, D.Q., Lamsal, L., Pan, L., Ding, C., Kim, H., Lee, P., Chai, T., Pickering, K.E., Stajner, I. 2015. Long-term NO_x trends over large cities in the United States during the great recession: Comparison of satellite retrievals, ground observations, and emission inventories. *Atmospheric Environment*, 107, 70-84.

U.S. EPA. 2014. U.S. Environmental Protection Agency. National Emissions Inventory version 2. <https://gispub.epa.gov/neireport/2014/>. Accessed May 2018.

U.S. EPA. 2017. U.S. Environmental Protection Agency. National Air Quality: Status and Trends of Key Air Pollutants. <https://www.epa.gov/air-trends>. Accessed June 2017.

U.S. EPA. 2018a. U.S. Environmental Protection Agency. AP-42: Compilation of Air Emissions Factors, <https://www.epa.gov/air-emissions-factors-and-quantification/ap-42-compilation-air-emissions-factors>. Accessed May 2018.

U.S. EPA. 2018b. U.S. Environmental Protection Agency. National Emissions Inventory. <https://www.epa.gov/air-emissions-inventories/national-emissions-inventory-nei>. Accessed May 2018.

U.S. EPA. 2019. U.S. Environmental Protection Agency. Clean Air Markets: Power Plant Emission Trends. <https://www.epa.gov/airmarkets/power-plant-emission-trends>. Accessed March 2019.

Van Zanten, M.C., Wichink Kruit, R.J., Hoogerbrugge, R., Van der Swaluw, E., van Pul, W.A.J. 2017. Trends in ammonia measurements in the Netherlands over the period 1993-2014. *Atmos. Environ.* 148, 352-360. <http://dx.doi.org/10.1016/j.atmosenv.2016.11.007>.

von Bobrutzki, K., Braban, C. F., Famulari, D., Jones, S. K., Blackall, T., Smith, T. E. L., Blom, M., Coe, H., Gallagher, M., Ghalaieny, M., McGillen, M. R., Percival, C. J., Whitehead, J. D., Ellis, R., Murphy, J., Mohacsi, A., Pogany, A., Junninen, H., Rantanen, S., Sutton, M. A., Nemitz, E. 2010. Field inter-comparison of eleven atmospheric ammonia measurement techniques. *Atmos. Meas. Tech.*, 3 (1): 91–112, doi:10.5194/amt-3-91-2010.

Vitousek, P.M., Aber, J.D., Howarth, R.W., Likens, G.E., Matson, P.A., Schindler, D.W., Schlesinger, W.H., Tilman, D.G. 1997. Human alteration of the global nitrogen cycle: Sources and consequences. *Ecological Applications*, 7, 737-750.

Warner J.X., Wei Z., Strow L.L., Dickerson R.R., Nowak, J.B. 2016. The global tropospheric ammonia distribution as seen in the 13-year AIRS measurement record. *Atmos. Chem. Phys.* 16, 5467-5479.

Warner J.X., Dickerson R.R., Wei Z, Strow L.L., Wang Y., Liang Q. 2017. Increased atmospheric ammonia over the world's major agricultural areas detected from space. *Geophys. Res. Lett.*, 44. doi:10.1002/2016GL072305.

Weber, R.J., Guo, H., Russell, A.G., Nenes, A. 2016. High aerosol acidity despite declining atmospheric sulfate concentrations over the past 15 years. *Nat. Geosci.*, 9, 282–285. <https://doi.org/10.1038/ngeo2665>.

Wood Environment & Infrastructure Solutions Environment & Infrastructure, Inc. 2018a. Clean Air Status and Trends Network (CASTNET) 2016 Annual Report. Prepared for U.S. Environmental Protection Agency (EPA), Office of Air and Radiation, Clean Air Markets Division, Washington, DC. Contract No. EP-W-15-003. Gainesville, FL.

Wood Environment & Infrastructure Solutions Environment & Infrastructure, Inc. 2018b. Clean Air Status and Trends Network (CASTNET) 2015 Annual Report. Prepared for U.S. Environmental Protection Agency (EPA), Office of Air and Radiation, Clean Air Markets Division, Washington, DC. Contract No. EP-W-15-003. Gainesville, FL.

Wood Environment & Infrastructure Solutions Environment & Infrastructure, Inc. 2017. Clean Air Status and Trends Network (CASTNET) 2014 Annual Report. Prepared for U.S. Environmental Protection Agency (EPA), Office of Air and Radiation, Clean Air Markets Division, Washington, DC. Contract No. EP-W-15-003. Gainesville, FL.

Wu, Z., Schwede, D.B., Vet, R., Walker, J.T., Shaw, M., Staebler, R., Zhang, L. 2018. Evaluation and Intercomparison of Five North American Dry Deposition Algorithms at a Mixed Forest Site. *J. Advances in Modeling Earth Systems*, 10. <https://doi.org/10.1029/2017MS001231>.

Xing, J., Pleim, J., Mathur, R., Pouliot, G., Hogrefe, C., Gan, C.-M., Wei, C. 2013. Historical gaseous and primary aerosol emissions in the United States from 1990 to 2010. *Atmos. Chem. Phys.*, 13: 7531-7549, [10.5194/acp-13-7531-2013](https://doi.org/10.5194/acp-13-7531-2013).

Zhang, L., Vet, R., O'Brien, J.M., Mihele, C., Liang, Z., Wiebe, A. 2009. Dry deposition of individual nitrogen species at eight Canadian rural sites, *J. Geophys. Res.*, 114, D02301, [doi:10.1029/2008JD010640](https://doi.org/10.1029/2008JD010640).

Zhang, Y., Mathur, R., Bash, J. O., Hogrefe, C., Xing, J., Roselle, S. J. 2018. Long-term trends in total inorganic nitrogen and sulfur deposition in the U.S. from 1990 to 2010. *Atmos. Chem. Phys.*, 18(12), pp. 9091-9106. <https://doi.org/10.5194/acp-18-9091-2018>.

Zhu, L., Henze, D.K., Cady-Pereira, K.E., Shephard, M. W., Luo, M., Pinder, R.W., Bash, J.O., Jeong, G.-R. 2013. Constraining U.S. ammonia emissions using TES remote sensing observations and the GEOS-Chem adjoint model, *J. Geophys. Res. Atmos.*, 118: 3355–3368, [doi:10.1002/jgrd.50166](https://doi.org/10.1002/jgrd.50166).

3.4.2. Spatial variability of ammonia in agricultural regions

Melissa Puchalski¹, John T. Walker², Gregory Beachley¹, Kristi H. Morris³

¹U.S. EPA, Office of Air and Radiation, Washington, DC

²U.S. EPA, Office of Research and Development, Durham, NC

³National Park Service, Air Resources Division, Lakewood, CO

Research topic summary

Agriculture is known to be the main source of NH₃ emissions, but the variability of atmospheric NH₃ concentrations between sources and downwind areas is not well understood due to the rapid vertical mixing, deposition and remission of NH₃, atmospheric reactivity, and sporadic and undocumented sources. In the U.S., CTMs have generally been shown to underestimate atmospheric NH₃ concentrations in agricultural areas (Kelly et al., 2014; Battye et al., 2016; Zhu et al., 2013), which are characterized by large spatial gradients. NH₃ plays a key role in deposition of reactive nitrogen (Nr) to sensitive ecosystems and the formation of particulate matter, so there is a clear need to improve understanding of spatial variability near and downwind of agricultural areas. Specifically, there is a need for additional studies near large agricultural emissions sources (i.e., animal feeding operations and fertilized crops) and clusters of sources to characterize spatial variability of NH₃ concentrations and deposition at the local to landscape scale. Both high-time resolution measurements to characterize diurnal patterns and spatially dense time-integrated (passive) measurements to resolve spatial gradients are needed. Studies that inform questions of sub-grid variability at spatial scales representative of CTM grid sizes are needed to facilitate appropriate measurement to model comparisons. This need could be met in the near-term as the technologies for such studies are readily available.

Conclusions drawn by gradient studies need to be categorized relative to emission source type and strength. This could include the size of the nearest agricultural facility (e.g. the number of livestock at an animal feeding operation), the type of agricultural activity (e.g. crop production vs. animal husbandry), and seasonality of management activities such as timing of fertilizer applications. These results could be reconciled with existing emission inventories and models. Concentration gradients with distances from each of these sources could inform improvements to gridded CTMs. The scope and type of collaboration needed to supplement field study databases on such a large scale could take some time and be a long-term goal, but little is needed for technological development and initial deployment, so progress could begin in the near-term. Improvement of emission inventories over the long term, including the eventual development of facility-scale emissions for Confined Animal Feeding Operations (CAFOs) and

improved emissions from fertilized soils, needs to be considered in the design of these studies. Thus, collaboration between the air quality and agricultural modeling and measurement groups is essential.

Expanded monitoring of NH_3 in agricultural areas and improvements to the CTMs will lead to improved total deposition estimates. For example, the NADP's total deposition hybrid maps (TDep maps) currently are not bias-adjusted using measured NH_3 concentrations from AMoN. Ammonia is the only pollutant that is not bias-adjusted prior to calculating the dry deposition fluxes due in part to the uncertainty in the spatial variability (how great is the radius of influence from an individual monitoring location) and the influence of undocumented emission sources, such as vehicles, industrial processes, soils and vegetation. Improved understanding of spatial variability, particularly near significant source regions, will help develop methods for incorporating NH_3 monitoring data into the TDep process.

Introduction

Approximately 80% of the anthropogenic NH_3 emissions in the U.S. are from agricultural sources with CAFOs and chemical fertilizer use accounting for ~ 55% and 25%, respectively (U.S. EPA, 2014; Vitousek et al., 1997; Aneja et al., 2009; Battye et al., 2003). The use of NH_3 as a fertilizer has dramatically increased over the past century and is expected to increase as the demand for food and biofuels continues to rise (Erisman et al., 2008). Fenn et al. (2018) noted the NH_3 emissions from on-road sources may contribute more to the NH_3 inventory in urban areas than agriculture, but here we focus specifically on the spatial distribution of NH_3 in agricultural regions.

Agricultural NH_3 emissions in the U.S. are reported in the EPA's National Emissions Inventory (NEI) database. Emissions from livestock are estimated by applying animal and management specific emission factors to county level animal population data to produce daily county-level emissions (U.S. EPA, 2014; McQuilling et al., 2015; Pinder et al., 2004). The NEI NH_3 emissions are then processed through the Sparse Matrix Operator Kernel Emission (SMOKE) model (<https://www.cmascenter.org/smoke/>) to provide gridded hourly emissions for use in CTMs such as CMAQ. For fertilized soils, the Fertilizer Emission Scenario Tool for CMAQ (FEST-C, <https://www.cmascenter.org/fest-c/>) simulates daily fertilizer application using the Environmental Policy Integrated Climate (EPIC) model (Cooter et al., 2012). Soil biogeochemistry simulated in EPIC provides temporally and spatially resolved estimates of the soil NH_3 emission potential, which is used within the CMAQ bi-directional modeling framework (Bash et al., 2013) to provide hourly NH_3 emissions from fertilized soils.

Once emitted into the atmosphere, NH_3 can rapidly dry deposit to the local landscape depending on micrometeorological patterns, physical structure of the vegetation, and chemical characteristics of the soil and vegetation (Loubet et al., 2009). Further downwind, NH_3 is exchanged bidirectionally between the atmosphere and biosphere in relation to the difference

between the atmospheric concentration and the surface compensation point (Flechard et al., 2013). NH_3 also readily undergoes transformation (reactions with acidic gases and aerosols) from gas to fine particulate matter (NH_4^+), which dry deposits more slowly than NH_3 and is therefore transported longer distances (Aneja et al., 2001; Fowler et al., 1998; Ianniello et al., 2011). While dry deposition of NH_3 dominates at the typical CTM grid scale (~ 10 km) in source regions, wet deposition of NH_x ($\text{NH}_3 + \text{NH}_4^+$) becomes more important with increasing transport distance (Dennis et al., 2010).

The distribution of NH_3 sources across the landscape and the characteristics of dispersion, deposition, and aerosol formation downwind lead to large spatial and temporal variability of NH_3 in agricultural areas. Ammonia concentrations and deposition fluxes in agricultural source regions are therefore difficult to predict without accurate facility-scale emission estimates and high-resolution temporal and spatial meteorological and ambient concentration measurements (Henze et al., 2009; Wu et al., 2008) to calibrate and evaluate models. These challenges have been highlighted in European studies aimed at characterizing fine-scale patterns of NH_3 deposition in agricultural landscapes (Sutton et al., 1998; Dragosits et al., 2002; Vogt et al., 2013). In the U.S., CTMs have generally been shown to underestimate atmospheric NH_3 concentrations in agricultural areas (Kelly et al., 2014; Battye et al., 2016; Zhu et al., 2013). For example, in 2014, as part of the DISCOVER-AQ study, aircraft measurements (below 1000-m) were compared to CMAQ model predictions, Tropospheric Emission Spectrometer (TES) satellite retrievals, and ground-based measurements in NE Colorado, an area heavily influenced by large CAFOs. The CMAQ model underpredicted NH_3 concentrations by a factor of 1.5-4.2 with the largest differences occurring in the summer months across a region with intensive agricultural activities (Figure 1) (Battye et al., 2016).

Satellite observations are becoming an increasingly useful tool for characterizing the large spatial gradients in NH_3 concentrations typical of agricultural areas. Pinder et al. (2011) summarized a 10-month study period in 2009 comparing the TES NH_3 retrievals with surface measurements deployed across a transect in an agricultural region in Eastern NC. Consistent with ground-based measurements, TES captured the general patterns in NH_3 concentrations across a large emission gradient. Satellite data are also being used to better understand the performance of CTMs in predicting NH_3 concentrations in agricultural areas (Battye et al., 2016; Schiferl et al., 2016; Lonsdale et al., 2017). While satellites are a useful tool for understanding spatial variability over agricultural regions, they are, however, limited by coverage area, pass-over times, detection limits, and cloud cover. Expanded ground-based monitoring is needed in agricultural areas of the U.S. for evaluation of CTMs as well as validation and improvement of satellite NH_3 products.

With regard to the improvement of total N deposition budgets, better characterization of the spatial variability of NH_3 and subsequent improvements to CTMs described above will also benefit the total deposition (TDep) mapping methodology used by NADP (Schwede and Lear, 2014). Currently, the TDep process relies solely on CMAQ for estimates of NH_3 dry deposition,

which is modeled using a bidirectional flux framework. For HNO_3 , NO_3^- , and NH_4^+ , monitoring data are used within the TDep process to directly estimate deposition and to bias correct CMAQ deposition fields. NH_3 monitoring data (i.e., AMoN) are not currently used in the TDep process, partly due to a lack of understanding of the spatial variability of NH_3 concentrations in agricultural regions and the “radius of influence” for a monitoring location as described by Schwede and Lear (2014). Expanded monitoring to characterize spatial variability in agricultural areas is needed to develop a methodology for incorporation of NH_3 monitoring data into the TDep mapping process.

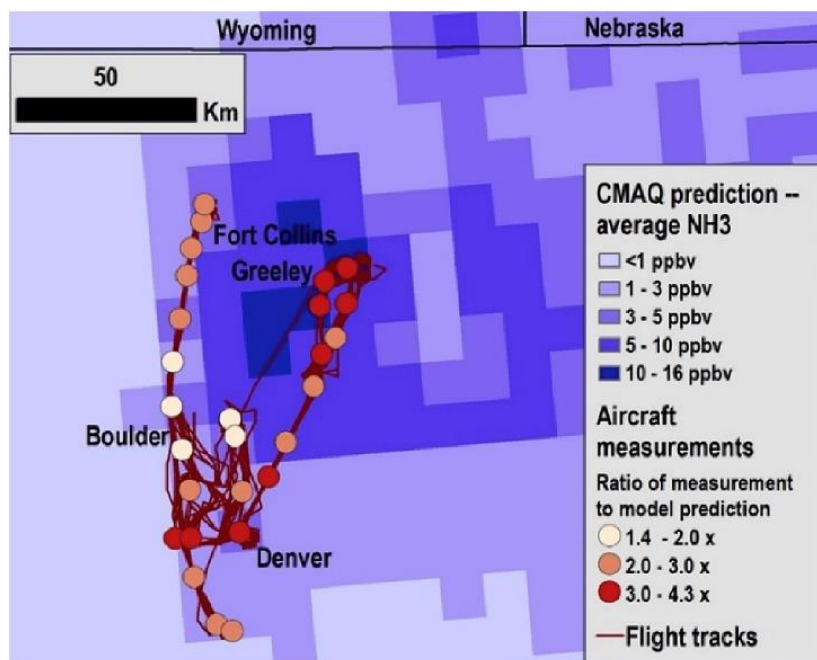

Figure 1. Aircraft measurements and CMAQ model estimates of NH_3 concentrations in northeast Colorado. CMAQ NH_3 concentrations shown in blue grids with the ratio of aircraft NH_3 measurements to model predictions shown as circles. The largest model errors were near Greeley, CO where some of the largest CAFOs in the U.S. are located (from Battye, et al. 2016).

State of the Science

Spatial variability studies

Ambient NH_3 concentrations are correlated with the magnitude of NH_3 emissions on a regional scale. However, the magnitude of NH_3 concentrations and deposition within smaller areas varies depending on the emissions source type, meteorology and surface characteristics (i.e. natural, semi-natural or agricultural). Examples of spatial concentration gradients across

agricultural regions in the U.S. have been published in the literature, but extrapolating results to other animal production facilities or emissions source types is difficult. In the southeastern U.S., North Carolina has been the subject of several spatial variability studies given the large number of CAFOs and crop production on the coastal plain (Walker et al., 2000; 2004; 2008; 2014; Pinder et al., 2011). Measurements over a 2-year period at a 5000-head swine facility showed concentrations at the barn/lagoon complex averaged $\sim 170 \mu\text{g NH}_3 \text{ m}^{-3}$ with concentrations declining rapidly with distance from the facility to $\sim 10 \mu\text{g NH}_3 \text{ m}^{-3}$ at a distance of 700 m (Figure 2; Walker et al., 2008). At a 4-million bird poultry operation, the average NH_3 concentration was $16.5 \mu\text{g NH}_3 \text{ m}^{-3}$ at 800 m downwind, declining to $0.75 \mu\text{g NH}_3 \text{ m}^{-3}$ at a distance 10.4 km (Figure 2). Across eastern North Carolina, annual average air concentrations are typically below $1.0 \mu\text{g NH}_3 \text{ m}^{-3}$ at distances more than a few kilometers from the nearest CAFO (Figure 2). The spatial trends across eastern NC characterized by in-situ measurements are consistent with satellite observations (Pinder et al., 2011).

The Carolina Ammonia Monitoring Network (CAMNet) observations in Figure 2 highlight the spatial variability that can occur at the landscape scale in areas where NH_3 emissions are dominated by CAFOs. While concentrations generally decrease with increasing distance from the nearest CAFO, average NH_3 concentrations can vary by an order of magnitude for distances between 500 m and 2 km. The overall pattern shown in Figure 2 may be different in other regions with different magnitude and spatial distribution of emissions, vegetation types and coverage, soil types, and meteorology.

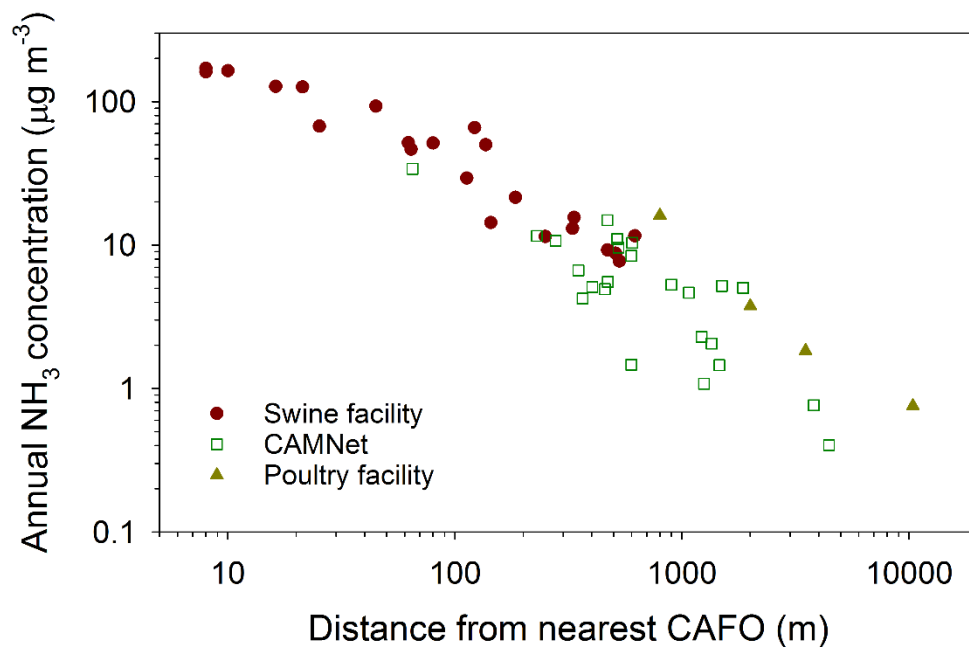

Figure 2. Examples of NH₃ concentration versus distance from the nearest CAFO at sites in eastern NC (Pinder, 2011; Walker et al., 2008; Walker et al., 2014). CAMNet refers to the 25-site Carolina Ammonia Monitoring Network (Pinder et al., 2011), which is no longer active.

Spatial variability studies have also been performed in agricultural areas in the Midwest and Northeastern Colorado. In a study performed by the U.S. EPA in 2016, additional passive NADP AMoN NH₃ samplers were deployed in concentric circles at different distances (from ~7 to 70 km) around the Fort Collins, CO and Bondville, IL primary AMoN sites (Puchalski et al., 2016). The goal of the study was to assess the spatial correlation of locations around the primary AMoN site (9 sites around Bondville and 18 sites around Fort Collins to help assess the more complex topography) to inform potential refinements to the method for estimating the range of influence used in the TDep mapping process. The Bondville and Fort Collins sites were selected as they are impacted by NH₃ emissions; Fort Collins is situated near large animal operations to the East while Bondville is located in a region where emissions are primarily from fertilized soils rather than CAFOs. Figure 3 shows the passive NH₃ sites in relation to the CAFOs and Rocky Mountains in the Fort Collins region. Fort Collins is represented by the CO13 AMoN site.

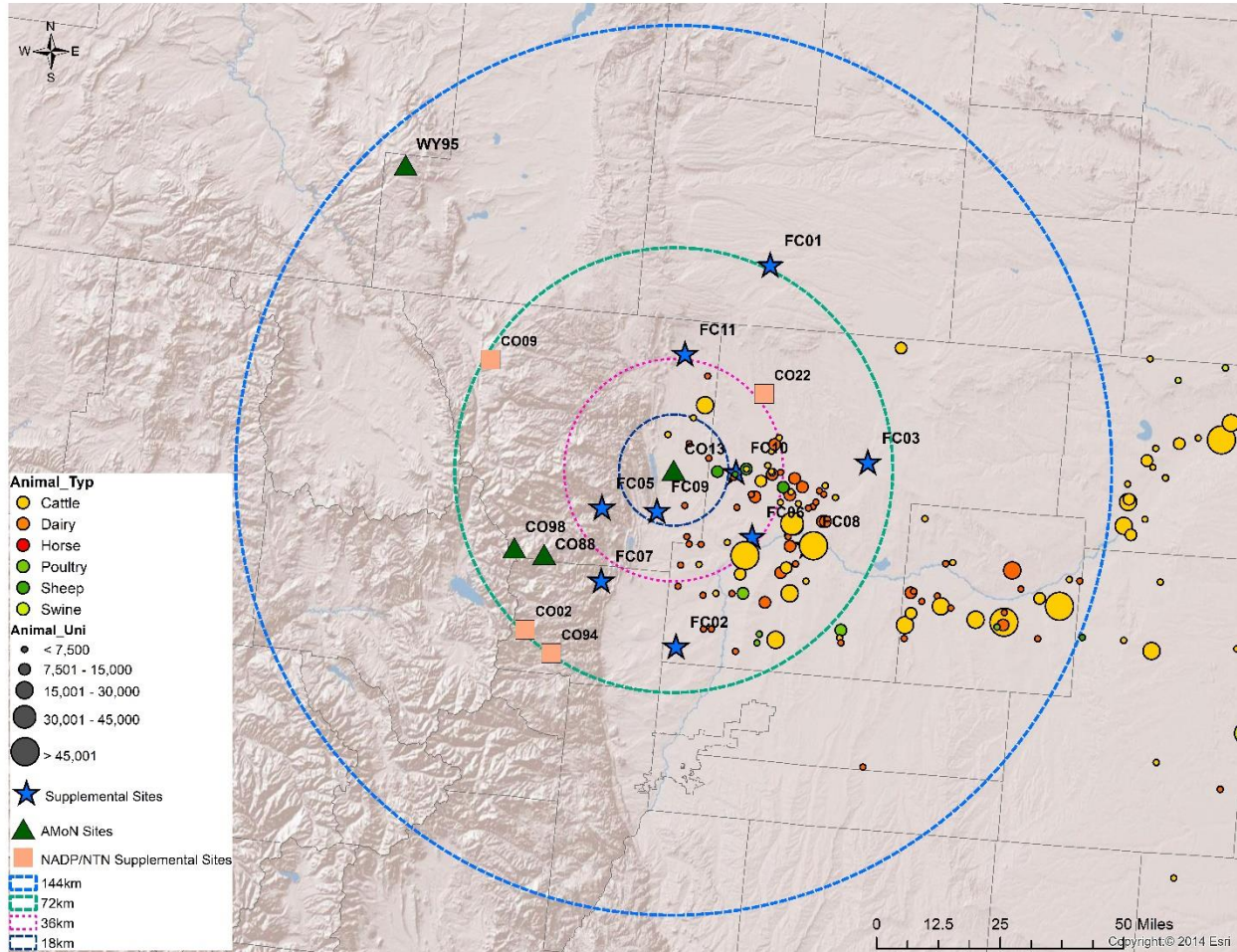
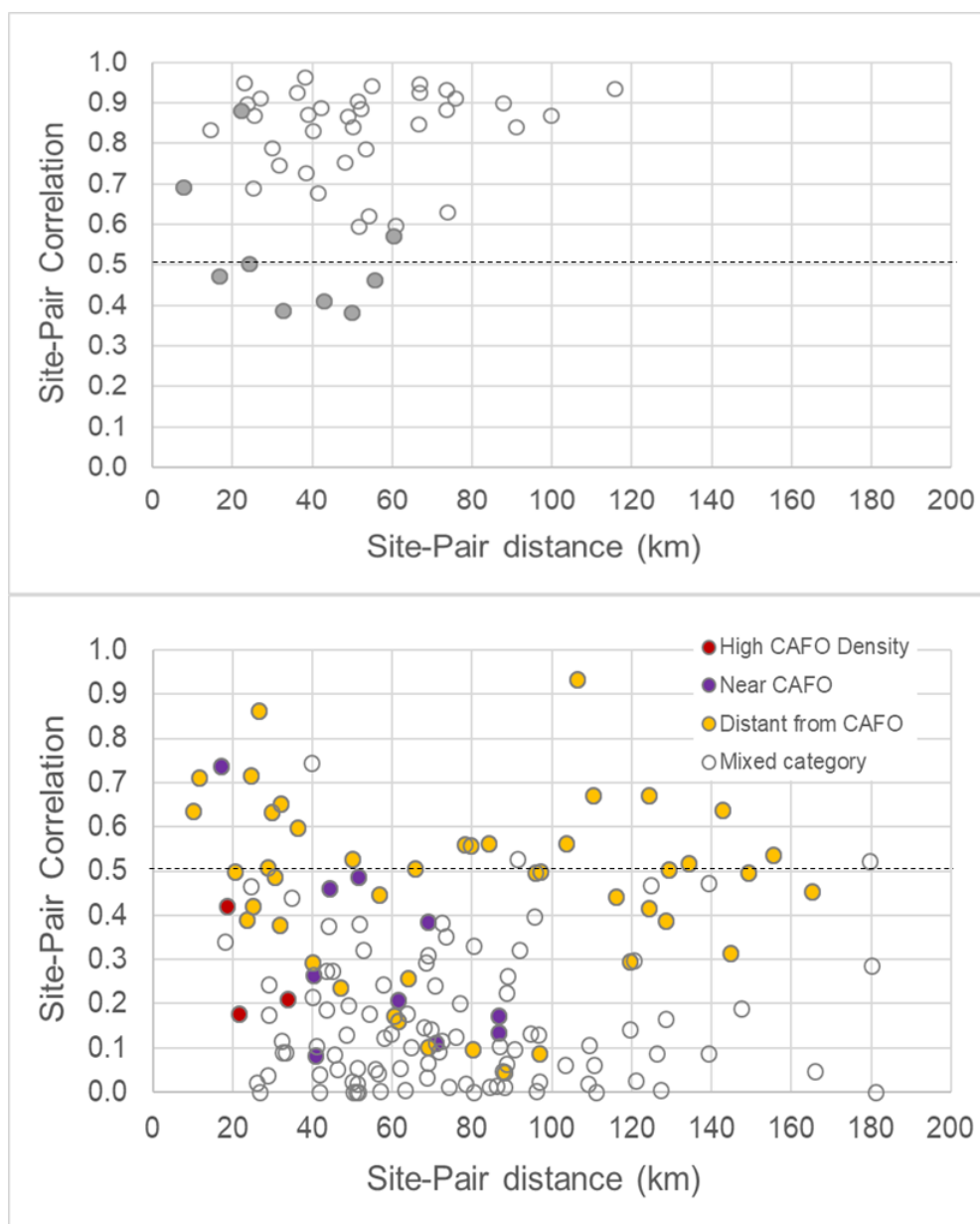

Figure 3. Fort Collins spatial variability site locations and CAFO locations (provided by Colorado Department of Public Health and Environment)

NH₃ concentrations were analyzed for each site pairing using non-linear least squares to quantify correlations in the time-series. Correlations for the site pairings were then plotted against the distance between the site pair locations. As shown in Figure 4a for Bondville, AMoN samples were highly correlated ($R^2 > 0.6$) except for one location (shown in Figure 4a with grey dots). These results suggest that in regions where NH₃ emissions are primarily from fertilized soils, an AMoN 2-week sample is representative of the surrounding area over distances of 120 km or more. Samples for this study were only collected over a year, so any interannual variability was not considered and may need to be looked at in more detail.

Results for the Fort Collins area showed that average NH₃ concentrations in high CAFO density areas decreased by a factor of 10 to $\sim 1 \mu\text{g m}^{-3}$ at sites 40 km distant from those sources. This conclusion supports observations in the CAMNet North Carolina study (Figure 2), though with a lower rate of decrease over distance. This could be influenced by many factors including strength or type of source, and the topography and meteorology of the area. The degree of correlation between site-pairs in Ft. Collins (Figure 4b) was much lower and more difficult to interpret than Bondville, likely due to the localized CAFOs. Categorizing the sites according to

their distance from the CAFOs (i.e. sites in high CAFO density areas, sites near high CAFO density areas (~ 5 to 10 mi), and sites distant from CAFO areas) did demonstrate some grouping of the relationship in site-pair correlation with site-pair distance, but any definitive conclusions are difficult to draw. The proximity of the high CAFO density area makes it difficult to deconvolute the contributions of local emission fluctuations with regional background concentrations and more characterization of near-source site concentrations with respect to local emissions is needed.



Figures 4a & b. Plots of the correlation R^2 values for biweekly AMoN NH_3 samplers collected at site-pairs from (a) Bondville, IL and (b) Fort Collins, CO versus the distance between the site-pairs (km). For Bondville, all correlations below an R^2 of 0.6 belong to a single location (grey-filled dots).

Day et. al. (2012) also measured NH_3 concentrations in the Fort Collins area and found average concentrations ranging from $3.4 \mu\text{g m}^{-3}$ at rural grasslands to $31.5 \mu\text{g m}^{-3}$ near large CAFOs in Weld county. Some of the largest feedlots in the U.S. are located in Weld county with over 500,000 cattle (USDA, 2014). The concentration gradient decreased nearly 10-fold within 20 km of a large CAFO located near Kersey, CO. To further assess the temporal and spatial variability of NH_3 concentrations in the same source region, Li et. al. (2017) measured weekly concentrations of NH_3 at 14 locations during the summers of 2010 to 2015 using passive NH_3 samplers. Weekly average NH_3 concentrations ranged from 2.66 to $42.7 \mu\text{g m}^{-3}$, with the highest concentrations near large CAFOs.

Bittman et. al. (2015) showed good correlation between in situ NH_3 measurements and estimated emissions within 4 km grid cells in a rural area in British Columbia where an outbreak of Avian Influenza caused the poultry population to drop 90%. The variability between grid cells was significantly greater at the Abbotsford site located near a high density of poultry operations (average of 228,000 broilers in 9 grid cells surrounding Abbotsford site). Weekly emissions were validated as the population was reintroduced slowly and deliberately, illustrating the need for more accurate data on animal operations to improve emission inventories.

In another study, distinct concentration gradients were quantified using passive samplers deployed around different emission sources, including a dairy barn, tallgrass prairie, managed cornfield, and CAFO (Felix et al., 2014). For example, the concentration ($109 \mu\text{g m}^{-3}$) decreased steeply within the first 100 m away from the CAFO with 30,000 head of beef cattle while the concentrations across the managed cornfield were generally more homogenous ($2\text{-}20 \mu\text{g m}^{-3}$) except after fertilizer application (135 kg N/ha).

Over a fertilized corn field in central Illinois, the average NH_3 concentration was $2.6 \pm 2.0 \mu\text{g m}^{-3}$ between May and September with the highest concentrations occurring within two weeks after fertilization, which is similar to results measured over a corn field in North Carolina (Nelson et al., 2017, Walker et al., 2013). However, the maximum and minimum emissions from the crop were greater in North Carolina (Walker et al., 2013) than those measured in Illinois (Nelson et al., 2017), which could be related to the amount and timing of fertilizer application, method of application, soil type, and meteorology. These results highlight the need for collecting such information to allow for extrapolating the ambient concentration and fluxes to similar agricultural areas.

Emissions inventories

The EPA's NEI is the most complete emission inventory for the U.S., but the methods for estimating agricultural emissions of NH_3 including details on source strength and spatial allocation, require improvement for more accurate modeling of NH_3 concentrations and deposition. The NEI is released every three years with data provided by State, Local, and Tribal air agencies for sources within their jurisdiction. Agricultural emissions, the major source

category for NH_3 emissions, are estimated within the NEI as non-point source emissions by county and reported every 3-years. An example of the NEI output for NH_3 emissions is shown in Figure 5 (U.S. EPA, National Emissions Inventory version 2, 2014). Currently, the 2017 NEI is not expected to be released until March 2020. The frequency of the updates and aggregation to the county scale make the emissions difficult to utilize for process-level modeling. The reported agricultural emission inventories are based on emission factors from animals or fertilizers under certain field conditions, which are generalized to county-level animal activity and fertilizer sales data. Emissions vary by meteorological conditions, livestock diet, and waste management and storage (Hristov et al., 2011). Results from the NEI are used as input into the SMOKE model to provide a finer scale resolution than the NEI for use in CTMs. The Improved Spatial Surrogate (ISS) method was developed to further improve the spatial resolution within a grid cell. The ISS method has been tested over the Midwest using a 4 x 4 km grid. Results from the ISS show individual emissions peaks on days post fertilization are 2.5-8 times greater than those estimated by SMOKE (Balasubramanian et al., 2015). Ultimately, a facility-scale emission inventory is needed to properly spatially allocate emissions within gridded CTMs.

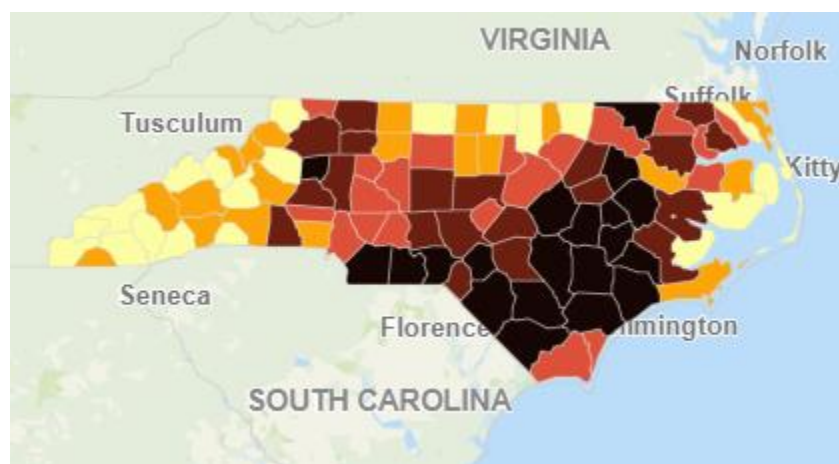

Figure 5. NEI 2014 county level NH_3 emissions for North Carolina. Yellow counties represent 0-0.63 Tons per Square Mile through black which represents 3.5 - 34.8 Tons per Square Mile NH_3 . (U.S. EPA, 2014).

Additional data are also needed to improve emissions from fertilized soils, including information on fertilizer types and the temporal dynamics of soil nitrogen concentrations after fertilization. EPA uses the EPIC model coupled with CMAQ to simulate NH_3 emissions from agricultural operations in recent years. EPIC allows user-defined farm management configurations to simulate nitrification of soils with input that includes soil moisture, ambient pH, and temperature which drive the biogeochemical processes at the soil and canopy level (Cooter et al., 2010). The EPIC model provides $[\text{NH}_4^+]$ and $[\text{H}^+]$ which are used as input into CMAQ to estimate surface compensation points needed to model the bi-directional fluxes of NH_3 . Additional studies are needed to evaluate EPIC against soil biogeochemical N_r

measurements and NH₃ fluxes for a wider range of fertilizer types, including increased N efficiency formulas, application methods, and soil types.

Future research

A higher spatial density of NH₃ monitoring sites in agricultural source regions is needed to fill geographic gaps experiencing strong spatial gradients. Existing passive sampling technology (AMoN) can be used to better quantify the spatial variability of NH₃ in agricultural regions. This would include expansion of the AMoN network to capture broader spatial patterns combined with special studies to examine more local deposition patterns around individual or clusters of sources. A near term goal would be to expand the AMoN network in agricultural areas in the Western, Midwest, and Eastern U.S. Design of this expanded monitoring could be guided by satellite NH₃ measurements to identify large gradients in air concentrations where monitoring is currently sparse or non-existent. Given the existing AMoN infrastructure, this research need could be pursued in the relatively near term with limited resources.

There is a need for additional gradient studies near individual and groups of agricultural sources to better understand spatial variability in air concentrations and deposition and to inform questions of sub-grid variability in CTMs. For example, the domain for a spatial variability study may be designed to encompass a 4 x 4 or 12 x 12 km area for overlap with a CMAQ model grid. These studies would primarily employ time-integrated passive samplers to characterize spatial gradients but could also include highly time-resolved meteorological and ambient NH₃ concentration measurements to capture short-term variations and diurnal patterns. Time resolved measurements are needed to assess and improve the ability of CTMs to properly simulate the temporal variability in concentrations and deposition of NH₃ near sources. Time resolved NH₃ measurements can also be used to apply a temporal allocation to time-integrated (passive) measurements to simulate a diurnal profile for in-situ deposition modeling and to better understand the performance of passive samplers in near-source environments where concentrations may change rapidly. The results of these gradient studies will provide information on the near-source spatial variability, but also help to characterize the emission sources in terms of strength and temporal variations. This data would be useful to improve existing emissions inventories and separate studies could be conducted for specific emission source types and strengths, as well as different spatial regions (i.e. North Central US versus Southeast), to better characterize variability among sources. Additionally, this information would improve parameterizations in CTMs.

The implementation of special gradient studies would be a longer-term goal and would include collaboration with USDA, EPA Regional Offices, States and industry stakeholders to identify study locations representing a range of animal and facility characteristics (e.g. operation-type, distances from density of surrounding operations, animal counts). When considering localized gradients near individual facilities, studies that address near field dispersion and deposition

within the context of a known or measurable emission source are needed such that local deposition can be expressed as a fraction of emissions.

Ultimately, emission inputs to CTMs need to resolve individual facilities and sizes and incorporate seasonal changes in animal activity, manure management, and fertilizer application to improve emission inventories. This is a long-term goal that will require close collaboration with industry stakeholders, USDA and other Federal agencies, as well as academic institutions. For emissions from fertilized soils, additional studies are needed to evaluate EPIC NH₃ emission potentials against soil biogeochemical N_r measurements and NH₃ fluxes for a wider range of soil and fertilizer types, including increased N efficiency formulas, application methods, and soil types. Engagement of the modeling community during study development would help to ensure that the collected information directly addresses modeling needs. Facility-scale emissions and better knowledge of spatial variability in air concentrations are needed to constrain the radius of influence around AMoN monitoring locations, particularly in areas where CAFOs are present. This information is needed to further develop methods for incorporating AMoN data in the TDep mapping methodology.

References

Aneja, V.P., Bunton, B., Walker, J.T., Malik, B.P. 2001. Measurement and analysis of atmospheric ammonia emissions from anaerobic lagoons. *Atmospheric Environment*, 35, 1949-1958.

Aneja, V.P., Schlesinger, W.H., Erisman, J.W. 2009 Effects of agriculture upon the air quality and climate: research, policy and regulations. *Environmental Science and Technology*, 43, 4234-4240.

Balasubramanian, S., Koloutsou-Vakakis, S., McFarland, D.M., Rood, M.J. 2015. Reconsidering emissions of ammonia from chemical fertilizer usage in Midwest USA. *Journal of Geophysical Research - Atmospheres*, 120, 6232-6246.

Bash, J.O., Cooter, E.J., Dennis, R.L., Walker, J.T., Pleim, J.E. 2013. Evaluation of a regional air-quality model with bi-directional NH₃ exchange coupled to an agro-ecosystem model. *Biogeosciences*, 10, 1635-1645.

Battye, W., Aneja, V.P., Roelle, P.A. 2003. Evaluation and improvement of ammonia emissions inventories. *Atmospheric Environment*, 37, 3873-3883.

Battye, W.H., Bray, C.D., Aneja, V.P., Tong, D., Lee, P., Tang, Y. 2016. Evaluating ammonia (NH₃) predictions in the NOAA National Air Quality Forecast Capability (NAQFC) using *in situ* aircraft, ground-level, and satellite measurements from the DISCOVER-AQ Colorado campaign. *Atmospheric Environment*, 140, 342-351.

- Bittman, S., Jones, K., Vingarzan, R., Hunt, D.E., Sheppard, S.C., Tait, J., So, R., Zhao, J. 2015. Weekly agricultural emissions and ambient concentrations of ammonia: Validation of an emission inventory. *Atmospheric Environment*, 113, 108-117.
- Cooter, E., Bash, J.O., Walker, J.T., Jones, M., Robarge, W. 2010. Estimation of NH₃ bi-directional flux from managed agricultural soils. *Atmospheric Environment*, 44, 2067 - 2166.
- Cooter, E.J., Bash, J.O., Benson V., Ran, L.-M. 2012. Linking agricultural management and air-quality models for regional to national-scale nitrogen deposition assessments, *Biogeosciences*, 9, 4023-4035.
- Day, D.E., Chen, X., Gebhart, K.A., Carrico, C.M., Schwandner, F.M., Benedict, K.B., Schichtel, B.A., Collett Jr., J.L. 2012. Spatial and temporal variability of ammonia and other inorganic aerosol species. *Atmospheric Environment*, 61, 490-498.
- Dennis, R.L., Mathur, R., Pleim, J., Walker, J.T. 2010. Fate of ammonia emissions at the local to regional scale as simulated by the Community Multiscale Air Quality model. *Atmospheric Pollution Research*, 1, 207-214.
- Dragosits, U., Theobald, M.R., Place, C.J., Lord, E., Webb, J., Hill, J., ApSimon, H.M., and Sutton, M.A. 2002. Ammonia emission, deposition and impact assessment at the field scale: a case study of sub-grid spatial variability. *Environmental Pollution*, 117, 147–158.
- Erismann, J.W., Sutton, M.A., Galloway, J., Klimont, Z., Winiwarter, W. 2008. How a century of ammonia synthesis changed the world. *Nature Geosciences*, 1, 636-639.
- Felix, J.D., Elliott, E.M., Gish, T., Maghirang, R., Cambal, L., Clougherty, J. 2014. Examining the transport of ammonia emissions across landscapes using nitrogen isotope ratios. *Atmospheric Environment*, 95, 563-570.
- Fenn, M.E., Bytnerowicz, A., Schilling, S.L., Vallano, D.M., Zavaleta, E.S., Weiss, S.B., Morozumi, C., Geiser, L.H., Hanks, K. 2018. On-road emissions of ammonia: An underappreciated source of atmospheric nitrogen deposition. *Science of the Total Environment*, 625, 909-919.
- Flechard, C. R., Massad, R.-S., Loubet, B., Personne, E., Simpson, D., Bash, J. O., Cooter, E. J., Nemitz, E., & Sutton, M. A., 2013. Advances in understanding, models and parameterizations of biosphere-atmosphere ammonia exchange. *Biogeosciences*, 10, 5183–5225.
- Fowler, D., Sutton, M.A., Smith, R.I., Pitcairn, C.E.R., Coyle, M., Campbell, G., Stedman, J. 1998. Regional mass budgets of oxidized and reduced nitrogen and their relative contribution to the nitrogen inputs of sensitive ecosystems. *Nitrogen, the Confer-N-s, Proceedings of the First International Nitrogen Conference*, 337-342.
- Henze, D.K., Seinfeld, J.H., Shindell, D.T. 2009. Inverse modeling and mapping US air quality influences of inorganic PM_{2.5} precursor emissions using the adjoint of GEOS-Chem. *Atmospheric Chemistry and Physics*, 9, 5877-5903.

Hristov, A.N., Hanigan, M., Cole, A., Todd, R., McAllister, T.A., Ndegwa, P.M., Rotz, A. 2011. Review: Ammonia emissions from dairy farms and beef feedlots. *Canadian Journal of Animal Science*, 91, 1-35.

Ianniello, A., Spataro, F., Esposito, G., Allegrini, I., Hu, M., Zhu, T. 2011. Chemical characteristics of inorganic ammonium salts in PM_{2.5} in the atmosphere of Beijing (China). *Atmospheric Chemistry and Physics*, 11, 10803-10822.

Kelly, J.T., Baker, K.R., Nowak, J.B., Murphy, J.G., Markovic, M.Z., VandenBoer, T.C., Ellis, R.A., Neuman, J.A., Weber, R.J., Roberts, J.M., Veres, P.R., de Gouw, J.A., Beaver, M.R., Newman, S., Misenis, C. 2014. Fine-scale simulation of ammonium and nitrate over the South coast air basin and San Joaquin Valley of California during CalNex-2010. *Journal of Geophysical Research – Atmospheres*, 119, 3600-3614.

Li, Y., Thompson, T.M., Van Damme, M., Chen, X., Benedict, K., Shoa, Y., Day, D., Boris, A., Sullivan, A.P., Ham, J., Whitburn, S., Clarisse, L., Coheur, P., Collett Jr., J.L. Temporal and spatial variability of ammonia in urban and agricultural regions of northern Colorado, United States. *Atmospheric Chemistry and Physics*, 17, 6197-6213.

Lonsdale, C. R., Hegarty, J. D., Cady-Pereira, K. E., Alvarado, M. J., Henze, D. K., Turner, M. D., Capps, S. L., Nowak, J. B., Neuman, J. A., Middlebrook, A. M., Bahreini, R., Murphy, J. G., Markovic, M. Z., VandenBoer, T. C., Russell, L. M., Scarino, A. J. 2017. Modeling the diurnal variability of agricultural ammonia in Bakersfield, California, during the CalNex campaign, *Atmospheric Chemistry and Physics*, 17, 2721–2739.

Loubet, B., Asman, W.A.H., Theobald, M.R., Hertel, O., Tang, Y.S., Robin, P., Hassouna, M., Damnggen, U., Genermont, S., Cellier, P., Sutton, M.A. 2009. Ammonia deposition near hotspots: processes, models and monitoring methods. In: Sutton MA, Reis S, Baker SMH (eds) UNECE expert workshop on atmospheric ammonia—detecting emission changes and environmental impacts. Springer, Dordrecht, The Netherlands. ISBN: 978–1-4020-9120-9, 205-267.

McQuilling, A.M., Adams, P.J. 2015. Semi-empirical process-based models for ammonia emissions from beef, swine, and poultry operations in the United States. *Atmospheric Environment*, 120, 127–136.

Nelson, A.J., Koloutsou-Vakakis, S., Rood, M.J., Myles, L.T., Lehmann, C., Bernacchi, C., Balasubramanian, S., Joo, E., Heuer, M., Vieira-Filiho, M., Lin, J. 2017. Season-long ammonia flux measurements above fertilized corn in central Illinois, USA, using relaxed eddy accumulation. *Agricultural and Forest Meteorology*, 239, 202-212.

Pinder, R., Strader, R., Davidson, C., Adams, P. 2004. A temporally and spatially resolved ammonia emission inventory for dairy cows in the United States. *Atmospheric Environment*, 38, 3747–3756.

- Pinder, R.W., Walker, J.T., Bash, J. O., Cady-Pereira, K.E., Henze, D.K., Luo, M., Osterman, G.B., Shephard, M.W. 2011. Quantifying spatial and seasonal variability in atmospheric ammonia with in situ and space-based observations, *Geophysical Research Letters*, 38, L04802.
- Puchalski, M., Schwede, D., Walker, J.T., Foley, K., Lear, G., Beachley, G., Haeuber, R. Improved reduced nitrogen deposition estimates in the United States: Spatial variability of ammonia. 7th International Nitrogen Initiative Conference (INI2016), Victoria, Australia. December 4-8th 2016.
- Schiferl, L.D., Heald, C.L., Van Damme, M., Clarisse, L., Clerbaux, C., Coheur, P., Nowak, J.B., Neuman, J.A., Herndon, S.C., Roscioli, J.R., Eilerman, S.J. 2016. Interannual Variability of Ammonia Concentrations over the United States: Sources and Implications. *Atmos. Chem. Phys.*, 16, 1230-12328.
- Schwede, D.B., Lear, G.G. 2014. A novel hybrid approach for estimating total deposition in the United States. *Atmospheric Environment*, 92, 207-220.
- Sutton, M.A., Milford, C., Dragosits, U., Place, C.J., Singles, R.J., Smith, R.I., Pitcairn, C.E.R., Fowler, D., Hill, J., ApSimon, H.M., Ross, C., Hill, R., Jarvis, S.C., Pain, B.F., Phillips, V.C., Harrison, R., Moss, D., Webb, J., Espenhahn, S.E., Lee, D.S., Hornung, M., Ullyett, J., Bull, K.R., Emmett, B.A., Lowe, J., and Wyers, G.P. 1998. Dispersion, deposition and impacts of atmospheric ammonia: quantifying local budgets and spatial variability. *Environmental Pollution*, 102, 349–361.
- USDA. 2014. Census of Agriculture. U.S. Department of Agriculture, National Agricultural Statistical Service, Washington DC (2014), p. 2012.
- U.S, EPA. 2014. U.S. Environmental Protection Agency, National Emissions Inventory version 2. <https://gispub.epa.gov/neireport/2014/> accessed July 23, 2018.
- Vitousek, P.M., Aber, J.D., Howarth, R.W., Likens, G.E., Matson, P.A., Schindler, D.W., Schlesinger, W.H., Tilman, D.G. 1997. Human alteration of the global nitrogen cycle: Sources and consequences. *Ecological Applications*, 7, 737-750.
- Vogt, E., Dragosits, U., Braban, C., Theobald, M.R., Dore, A.J., van Dijk, N., Tang, Y.S., McDonald, C., Murray, S., Rees, R.M., Sutton, M.A. 2013. Heterogeneity of atmospheric ammonia at the landscape scale and consequences for environmental impact assessment. *Environmental Pollution*, 179. 120-131.
- Walker, J.T., Aneja, V. P., Dickey, D. 2000. Atmospheric transport and wet deposition of ammonium in North Carolina, USA. *Atmospheric Environment*, 34, 3407-3418.
- Walker, J.T., Whitall, D.R., Robarge, W., Paerl, H.W. 2004. Ambient ammonia and ammonium aerosol across a region of variable ammonia emission density. *Atmospheric Environment*, 38, 1235-1246.

Walker, J.T., Spence, P., Kimbrough, S., Robarge, W. 2008. Inferential model estimates of ammonia dry deposition in the vicinity of a swine production facility. *Atmospheric Environment*, 42, 3407-3418.

Walker, J.T., Jones, M.R., Bash, J.O., Myles, L., Meyers, T., Schwede, D., Herrick, J., Nemitz, E., Robarge, W. 2013. Processes of ammonia air-surface exchange in a fertilized *Zea mays* canopy. *Biogeosciences*, 10, 981-998.

Walker, J.T., Austin, R., Robarge, W.P. 2014. Modeling of ammonia deposition to a Pocosin landscape downwind of a large poultry facility. *Agriculture, Ecosystem, and Environment*, 185, 161-175.

Wu, S.Y., Krishnan, S., Zhang, Y., Aneja, V. 2008. Modeling atmospheric transport and fate of ammonia in North Carolina – Part I: Evaluation of meteorological and chemical predictions. *Atmospheric Environment*, 42, 3419-3436.

Zhu, L, Henze, D.K., Cady-Pereira, K.E., Shephard, M.W., Luo, M., Pinder, R.W., Bash, J.O., Jeong, G.-R. 2013. Constraining U.S. ammonia emissions using TES remote sensing observations and the GEOS-Chem adjoint model. *Journal of Geophysical Research - Atmospheres*, 118, 3355-3368.

4. Enhanced Coordination to Address Stakeholder Issues and Resource Needs

Specific examples of research needed to improve Nr deposition budgets in the U.S. are presented in Chapter 3.0 (Table 3.1). These research topics address the interests of a broad group of stakeholders, including federal and state agencies, academia, industry, and non-profit groups. In this chapter, we describe several of the larger knowledge gaps that span across the needs of stakeholder groups in the areas of capacity building, science issues, and policy relevant issues. Capacity, in this case, refers to the infrastructure and resources to provide data (i.e., monitoring) and tools (i.e., models) required to address science and policy needs. Science issues represent the research needed to improve the fundamental understanding of Nr deposition. Science and capacity are inherently coupled; capacity facilitates scientific advancement which in turn leads to improvements to or expansion of capacity. Policy-relevant issues require the application of data, tools, and scientific understanding to develop and evaluate policies to protect ecosystems from Nr deposition. In the following Section (4.1) we describe three examples of broad knowledge gaps identified from Section 3.0 that cut across stakeholder interests and individually encompass elements of capacity building, science, and policy. These include: 1) *improved understanding of the linkages between agricultural emissions and Nr deposition*, 2) *better characterization of patterns and trends in Nr deposition*, and 3) *quantifying and reducing uncertainty in deposition estimates used for critical loads applications*. We

identify several specific opportunities for enhanced stakeholder coordination to address these gaps and then, in Section 4.2, offer examples of activities to increase stakeholder coordination.

4.1. Stakeholder Needs and Opportunities for Coordination

4.1.1. Improved understanding of the linkages between agricultural emissions and Nr deposition

Many of the science needs in Section 3.0 address knowledge and data gaps related to better understanding the linkages between agricultural emissions and Nr deposition. Figure 4.1 provides examples of science and policy issues encompassed by this broad research theme and stakeholders with interests in these issues. Examples of science issues include the need for improved:

- estimates of NH₃ emissions from agricultural sources for source apportionment and modeling of air quality, visibility, and Nr deposition
- understanding of the contribution of NH₃ to atmospheric PM and total Nr deposition budgets to land and water
- understanding of the indirect effects of agriculture on land use change (i.e., biodiversity impacts of NH_x deposition).

In addition to these science needs, improved atmospheric models and expanded monitoring to better resolve spatial variability of deposition and air concentrations within and downwind of agricultural areas (see Section 4.1.2.) represent capacity issues relevant to the role of agriculture in Nr deposition. Each of the science issues illustrated in Figure 4.1 has corresponding underlying policy issues. Regarding the policy-relevant questions listed in Section 2.0, this research theme addresses aspects of the development of total Nr deposition budgets needed to:

- link atmospheric Nr levels and speciation to deposition rates for specific ecosystems
- quantify critical loads and their exceedances
- determine the source(s) of Nr deposition in ecosystems experiencing exceedances
- evaluate the effectiveness of existing policies for managing Nr emissions

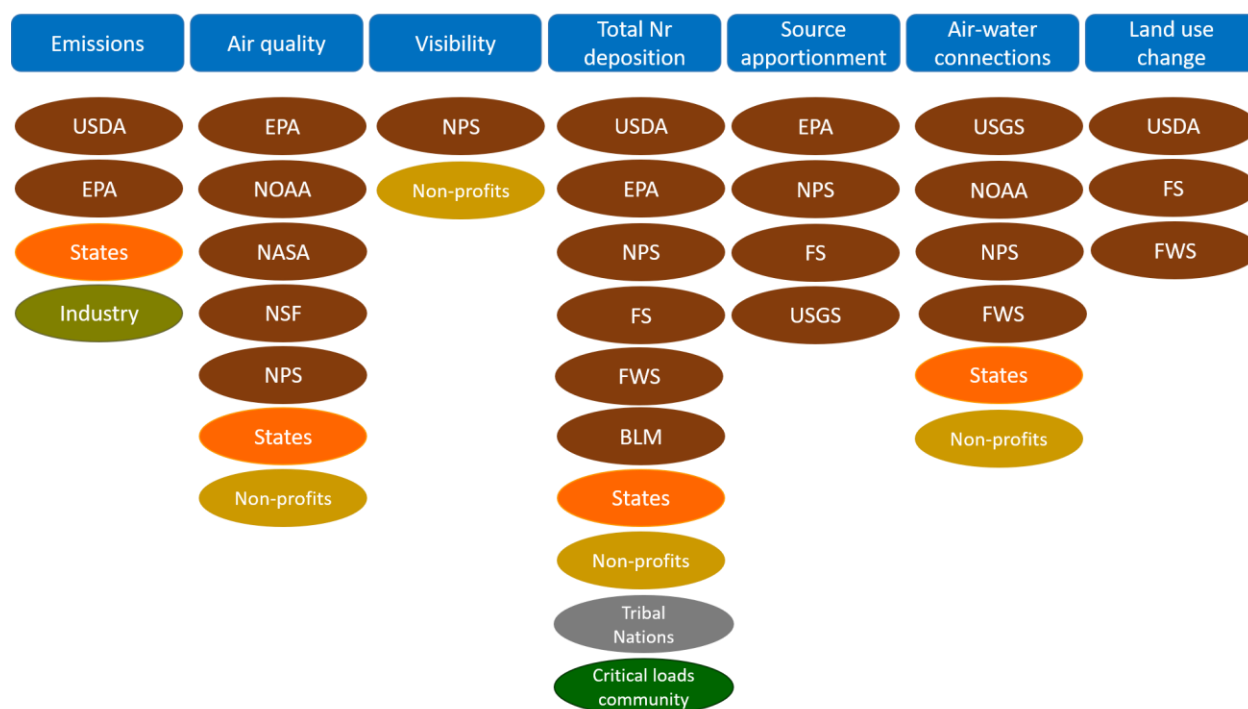

Figure 4.1. Schematic showing the Science and Policy issues associated with the “Linkage between agricultural emissions and Nr deposition” (top row) and examples of stakeholders (ovals) with interests in those issues. These issues are relevant to many different research themes.

Figure 4.1 illustrates the diversity of stakeholders with an interest in better understanding the linkage between agricultural emissions and Nr deposition. Federal agencies share a wide range of interconnected scientific and policy interests. For example, the USDA Agricultural Research Service (ARS) and USDA National Institute of Food and Agriculture (NIFA) address measurement and modeling of NH₃ emissions from fertilized soils and animal production. The USDA Natural Resources Conservation Service (NRCS) has an interest in developing and evaluating best management practices (BMPs) to reduce agricultural emissions, which can impact protected lands. EPA, NPS, NOAA, NASA, and NSF have a shared interest in better understanding atmospheric chemistry to inform air quality, visibility, and earth system processes. USGS has an interest in understanding the contributions of agricultural sources of Nr to impaired waters and ecosystem impacts in aquatic systems. Land management agencies (i.e., U.S. Forest Service (FS), NPS, USDA, Bureau of Land Management (BLM), U.S. Fish and Wildlife Service (FWS)) need total Nr deposition estimates to assess critical loads. Establishment of a critical Nr load for RMNP and a goal of reducing Nr deposition over time has brought together a range of stakeholders including the NPS, EPA, the State of Colorado, and Colorado agricultural producers. The producers have a stake in exploring ways to improve emissions estimates and develop cost

effective BMPs. We note that Figure 4 is intended as an example and is not comprehensive as a list of stakeholders or the issues relevant to the stakeholders included.

Collectively, the science underpinning the development of total Nr deposition budgets benefits the larger critical loads community. Enhanced coordination across these stakeholder groups would facilitate more rapid progress in implementing research needed to better understand the role of agriculture in Nr deposition at the national scale. Multi-organization large-scale field studies represent a specific opportunity for enhanced coordination under this research theme. Such studies that take advantage of existing infrastructure, analytical capability, and expertise across multiple stakeholders are the most cost-effective approach to developing the complex datasets needed to advance process-level scientific understanding. Historically, large-scale atmospheric measurement campaigns in the U.S. have been developed and coordinated by the atmospheric chemistry community. Opportunities exist for the TDep committee to engage with these efforts more directly (e.g., direct participation in field work, sampling design, development of RFAs) to advocate for science objectives that integrate atmospheric chemistry and ecological questions relevant to Nr deposition. For example, flux measurement campaigns require significant investment in real-time chemical sensors and infrastructure required for canopy-scale measurement platforms. This includes a wide variety of ancillary measurements (e.g., biogeochemistry, canopy structure) that are needed to relate fluxes to ecosystem characteristics. Flux measurement campaigns could combine analytical capability and sampling infrastructure for ground (EPA, NPS, NADP, States), aircraft-based (NOAA), and remotely sensed (NASA) atmospheric measurements with existing infrastructure for observations and accompanying long-term datasets of ecosystem processes (USGS, NPS, LTER, USGS). An example is the SANDS conducted at the U.S. Forest Service Coweeta Hydrologic Laboratory in southwestern North Carolina in 2015 -2016 (Chen et al., 2019), which combined Forest Service infrastructure and expertise for canopy scale flux measurements of carbon, water, canopy structure, and biogeochemistry, long-term measurements of NADP and CASTNET, and process-level chemistry and flux measurements of Nr by EPA.

4.1.2. Better characterization of patterns and trends in Nr deposition

Monitoring networks are a cornerstone for developing the information needed to characterize and address Nr deposition issues. In North America Nr science is grounded in several key monitoring programs including NADP and CASTNET. However, current network designs leave a number of important data gaps relevant to Nr deposition budgets. Several topics in Section 3.0 discuss these gaps and potential strategies to resolve them, including the leveraging of existing network infrastructure by expanding monitoring locations to fill key geographical gaps (e.g., urban and agricultural areas) as well as measuring additional compounds that are currently not captured in the national networks (e.g., ON; NO₂). As discussed below, many opportunities for enhanced stakeholder collaboration across existing air, water, and ecological monitoring networks were identified.

Expansion of NADP's NTN for urban deposition is a high priority (Section 3.1.4) monitoring objective where enhanced stakeholder collaboration could build on current air (e.g., National Core monitoring stations (NCore), Chemical Speciation Network (CSN)) and water monitoring (e.g., USGS) efforts. Urban areas represent a key geographical gap with respect to Nr deposition where "hotspots" have been observed (Decina et al., 2017) but atmospheric Nr contributions to urban water quality remain poorly understood. A study in Pittsburgh, Pennsylvania using N isotopes found that atmospheric deposition contributed a third of NO_3^- in urban stream water during storms (Divers et al., 2014), suggesting the air-water linkages could be substantial. NADP has recently begun to establish deposition monitoring stations in a limited number of U.S. cities to more systematically link deposition to Nr in urban waters. Additional sites are especially needed in urban corridors with heavy car traffic near waterbodies, such as Charleston and New Orleans (Amos et al., 2018), however, additional monitoring is still needed. The use of stable isotopes (Section 3.3.2.) as a tool to apportion sources could benefit from enhanced collaboration between air and water monitoring networks and academia. Techniques that are currently being developed for isotopes could be used to examine samples collected under existing water quality networks through government/academic partnerships, citizen science efforts, states, or tribes.

The urban deposition monitoring gap is of interest to multiple stakeholders, including EPA, USGS, states, and non-profit groups (e.g., Chesapeake Bay Foundation) with respect to understanding the sources of Nr impacting water quality and total maximum daily loads (TMDLs). Proper apportionment of sources of Nr to aquatic resources is of interest to many stakeholders, as is knowledge of urban sources of Nr pollution that ultimately impact water quality in coastal zones, including NOAA. Increased coordination of deposition and water quality monitoring would provide natural resource managers with better information to apportion sources of pollution, understand and anticipate trends, and assess benefits of BMPs, pollution control technologies, infrastructure upgrades, and environmental policies.

An important long-term change in atmospheric chemistry, which has implications for the secondary NAAQS and critical loads strategies, is the national-scale shift in the atmospheric Nr budget from a predominance of oxidized forms of Nr (NO_y) to reduced forms ($\text{NH}_3 + \text{NH}_4^+$) (Du et al., 2014; Li et al., 2016). This shift is expected to continue with declining NO_x emissions and steady or increasing NH_3 emissions (Ellis et al., 2013). As noted above, several of the research needs identified in Section 3.0 relate to knowledge of the contributions of NH_3 to total Nr deposition.

Expansion of AMoN in agricultural areas would address a monitoring need to better characterize trends and patterns in air concentrations of NH_3 that would inform several of the science and policy issues illustrated in Figure 4.1. In addition to providing data for trends analysis and model evaluation, expansion of AMoN would also allow for a more spatially dense implementation of bidirectional NH_3 flux modeling to provide dry deposition estimates. Development of the AMoN dry deposition model is a multi-disciplinary effort linking

atmospheric chemistry, air-surface exchange, and biogeochemistry, creating an opportunity for collaboration between NADP and national ecological networks such as Ameriflux and LTER. Micrometeorological and biogeochemical data collected by such networks are useful for modeling NH₃ dry deposition. Opportunities to collaborate with ecological networks, which are often supported by multiple entities, are a potential path toward expansion of the AMoN network and wider use of relevant ecological data for development and evaluation of deposition models. Figure 4.1 summarizes the broad group of stakeholders that could benefit from expansion of AMoN.

With respect to completeness of the Nr deposition budget, it is noted that organic forms of Nr are not currently measured in national monitoring networks and NO₂ is primarily measured in urban areas. These unmeasured forms of Nr can contribute significantly to total Nr deposition (Jickells et al., 2013; Nowlan et al., 2014). Adaptation of NTN methods to include bulk water-soluble ON in wet deposition would be an important step toward the development of more complete estimates of total Nr deposition, and represents an opportunity for collaboration between North American wet deposition networks (NADP, CAPMoN) to evaluate and standardize appropriate methods for routine measurements. This is an example of a scientific advancement (i.e., method development) that facilitates an expansion of capacity (i.e., monitoring). Characterization of the spatial variability of NO₂ by remote sensing to inform expanded ground-based monitoring for deposition applications represents an opportunity for enhanced coordination between NASA and existing networks such as CASTNET (Section 3.1.2.2.). Because NO₂ and ON can contribute significantly to Nr deposition across the country, more complete characterization of these components of the atmospheric Nr budget is relevant to the interests of the stakeholders identified under the total Nr deposition topic in Figure 4.1.

Regarding the overarching policy questions listed in Section 2.0, enhanced monitoring will improve total Nr deposition budgets needed to:

- link atmospheric Nr levels and speciation to deposition rates for specific ecosystems
- quantify critical loads and their exceedances
- reduce uncertainties in estimates of critical loads and exceedances
- determine the source(s) of Nr deposition in ecosystems experiencing exceedances
- evaluate the effectiveness of existing policies for managing Nr deposition
- inform the scientific basis for reviews of policies related to managing Nr pollution

4.1.3. Quantifying and reducing uncertainty in deposition estimates used for critical loads applications

Total deposition budgets derived from regional CTMs are used directly in ecosystem exposure and critical loads applications or feed into hybrid total deposition methodologies that combine measurements and modeling. Models are therefore critical for many stakeholders in their assessments of Nr deposition and its impacts and policy implications. Because the critical load

exceedance is a metric used to inform policy decisions, uncertainty in both the critical load and the exceedance itself (i.e., total deposition) must be understood. Uncertainties in model estimates of deposition result from spatial and temporal limitations in monitoring and knowledge gaps in model processes such as emissions (e.g., agricultural NH₃), meteorology (e.g., transport in complex terrain, precipitation), atmospheric chemistry (e.g. gas-aerosol partitioning), and deposition (e.g., dry deposition pathways, atmospheric scavenging). While the general improvement of modeling tools (e.g., accuracy, mechanistic completeness, processing time, resources for data processing) represents a capacity issue, improvement of process algorithms and development of methodologies to quantify uncertainties encompass a number of science issues detailed in Section 3.0. Quantification and reduction of uncertainties in model deposition estimates benefits a range of stakeholders that use total Nr deposition data (see Figure 4.1).

Natural synergies and opportunities for enhanced coordination can be found by using and sharing common models and modeling inputs (emissions, meteorology) and through model development and evaluation. While many productive collaborations have been developed within the TDep community, additional opportunities exist. Comprehensive comparisons of deposition processes among models used for deposition assessments in North America (CMAQ, CAMx, GEM-MACH) would directly inform the development of uncertainty estimates for total deposition. Development of more modular codes and software architectures that allow for easier implementation and comparison of different parameterizations is needed. Such efforts could draw on modeling expertise within EPA, NPS, ECCO, and NOAA. The incorporation of satellite data (NOAA, NASA) within the hybrid TDep methodology (EPA) could also be explored. Greater collaboration among the critical loads and deposition scientists (i.e., TDep and CLAD) is also needed. Deposition scientists need to understand the form of uncertainty that will be most useful to critical load efforts. For instance, a more qualitative metric may be adequate for some deposition assessments. Conversely, it is up to the deposition scientists to inform the critical loads scientists of the limitations of deposition measurements and models.

Regarding the overarching policy questions listed in Section 2.0, quantifying and reducing the uncertainty in total deposition estimates addresses aspects of the development of total Nr deposition budgets needed to:

- reduce uncertainties in estimates of critical loads and exceedances
- inform the scientific basis for reviews of policies related to managing Nr pollution

4.2. Strategies for Increasing Stakeholder Coordination

The various government agencies and other stakeholders listed in Figure 4.1 are actively working on aspects of Nr deposition. The challenge is to identify specific activities that will increase coordination among these groups. Some examples include:

- *Development of research projects with shared goals.* Building on the research examples identified in Section 3.0, develop projects in which there are shared goals across stakeholder groups.
- *Integration of TDep science needs into existing research programs.* The science needs identified in Section 3.0 could be incorporated into stakeholder research plans. In many cases this is already being done. For example, one of the main objectives of the USGS Network for Urban Atmospheric Nitrogen Chemistry in Denver and Boulder, Colorado, is to evaluate how incorporation of urban wet deposition data can change the NADP annual deposition map, a major component of the TDep mapping products. EPA and NPS are active participants of TDEP and needs and issues identified within TDep are often incorporated into their research plans.
- *Creation of new opportunities for collaborative research by promoting deposition science to be reflected in grant programs (e.g., EPA, NSF, USDA, NASA).* Comments and input on deposition science could be provided during the stakeholder input process for grant program requests for applications (RFAs). For example, USDA NIFA has several programs that involve air quality research, including but not limited to, the Agriculture and Food Research Initiative (AFRI) - Bioenergy, Natural Resources, and Environment Foundational Program. Federal scientists working in atmospheric deposition can collaborate and apply to some of these programs or partner with other research institutions. USDA NIFA accepts input for specific RFAs via email (Policy@nifa.usda.gov) and during the “NIFA listens” stakeholder sessions.
- *Increased communication between different scientific communities through organization of meetings, special sessions, and webinar series.*
- *Cross-stakeholder communication of programmatic reviews that emphasize the need for coordination on Nr.* The Board of Scientific Counselors review of EPA ORD research programs is an example. In August 2011, the EPA Science Advisory Board’s Integrated Nitrogen Committee (SAB INC) released *Reactive Nitrogen in the United States: An Analysis of Inputs, Flows, Consequences, and Management Options* (SAB, 2011). This report specifically urged increased coordination of Nr research both within EPA, and between EPA and other agencies.

The formation of a TDep stakeholder workgroup to organize and guide these activities has been initiated. The workgroup is open to all stakeholders, including federal agencies, tribal nations, international collaborators, (e.g., ECCC), industry, states, non-profits, and academia. The charge for this group, as directed by the larger TDep science committee, is to carry out and support activities such as those outlined above to promote stakeholder coordination on Nr deposition.

5. From Deposition to Ecosystem Response

In Section 2.3, we present a set of broad policy relevant questions that can drive deposition research to inform the effectiveness of air regulations to protect ecosystem health and to

further develop critical loads as a framework for managing deposition of nutrients and acidity. The science needs described in Section 3.0 directly address the deposition-focused questions in Section 2.3 and the research topics address the knowledge and data gaps relevant to critical loads by improving measurements and models of deposition, linking air concentrations and speciation to deposition, reducing uncertainties in critical loads and their exceedances, and determining the sources of Nr deposition. Collectively, outcomes of this research needs herein will inform the scientific basis for reviewing and evaluating the effectiveness of policies for managing Nr pollution, such as the secondary NAAQS and critical loads, water issues and agricultural sources.

From a scientific standpoint, the development of critical loads is currently a primary driver of deposition research. The purpose of the critical load is to quantitatively link atmospheric deposition to ecological response. Exceedance of the critical load can negatively affect aspects of ecosystem structure and function that produce the ecosystem services that benefit people (Munns et al., 2015), such as clean air and water, recreational opportunities, visibility, food and materials, and cultural and spiritual values. Deposition can be linked to changes in ecosystem services via ecological production functions. By linking air concentrations and atmospheric deposition to ecosystem response in the context of ecological production functions, critical loads provide a quantitative framework that can be used to inform resource management and policy decisions aimed at sustaining or improving human welfare.

Scientific aspects of the development of Nr critical loads include:

- relating ambient air concentrations to deposition
- quantifying deposition rates
- quantifying the relationships between deposition and ecosystem response
- relating those ecological changes to changes in the services ecosystems provided
- identifying the ecosystems most at risk to Nr deposition.

With atmospheric deposition as the focus of this document, science questions addressing ecosystem response are not directly addressed. As such, the policy relevant questions in Section 2.3 related to linking deposition to ecosystem response and ecosystem services represent an opportunity for extension of this work. As the TDep community moves forward to address the science needs documented here, closer engagement with the biogeochemical and ecological communities (e.g. CLAD) is needed to develop and prioritize science questions at the interface between ecosystem exposure and response. For example, as the representation of biogeochemical processes in deposition models becomes more mechanistically complete and the computational expense of running fully coupled air-water-land models becomes more feasible, exposure and ecophysiology become more explicitly linked. Thus, it becomes easier to quantitatively identify relationships between Nr deposition and ecosystem response and their interactions within the context of other drivers of ecosystem change such as climate. This area of research invites closer collaboration between deposition scientists and ecologists to develop

the models themselves and to identify and prioritize the measurements needed for model development and evaluation.

6. References (Sections 1, 2, 4, and 5)

Amos, H.M., Miniati, C.F., Lynch, J., Compton, J., Templer, P.H., Sprague, L.A., Shaw, D., Burns, D., Rea, A., Whittall, D., Myles, L., Gay, D., Nilles, M., Walker, J., Rose, A.K., Bales, J., Deacon, J., Pouyat, R. 2018. What goes up must come down: Integrating air and water quality monitoring for nutrients. *Environmental Science and Technology*, 52, 11441 – 11448.

Baron, J., 2006. Hindcasting nitrogen deposition to determine an ecological critical load. *Ecological Applications*, 16, 433-439.

Blett, T.F., Lynch, J.A., Pardo, L.H., Huber, C., Haeuber, R., Pouyat, R. 2014. FOCUS: A pilot study for national-scale critical loads development in the United States. *Environmental Science and Policy*, 38, 225-236.

Burns, D.A., Sullivan, T.J. 2015. Critical loads of atmospheric deposition to Adirondack Lake watersheds: A guide for policymakers. NYSERDA Technical Report, Albany, NY.

Chen, X., Walker, J.T., et al. 2019. Total nitrogen deposition budget for a high elevation montane forest in the southeastern U.S. *In prep.*

Clark, C.M., Phelan, J., Doraiswamy, P., Buckley, J., Cajka, J.C., Dennis, R.L., Lynch, J., Nolte, C.G., Spero, T.L. 2018. Atmospheric deposition and exceedances of critical loads from 1800-2025 for the conterminous United States. *Ecological Applications*, 28, 978-1002.

Clark, C.M., Bell, M.D., Boyd, J.W., Compton, J.E., Davidson, E.A., Davis, C., Fenn, M.E., Geiser, L., Jones, L., and T. F. Blett. 2017. Nitrogen-induced terrestrial eutrophication: cascading effects and impacts on ecosystem services. *Ecosphere* 8, 01877.

Compton, J.E., Harrison, J.A., Dennis, R.L., Greaver, T., Hill, B.H., Jordan, S.J., Walker, H., Campbell, H.V. 2011. Ecosystem services altered by changes in reactive nitrogen: a new perspective for U.S. decision making. *Ecology Letters*, 14, 804–815.

Cooter, E., Rea, A., Dennis, R., Bruins, R. and Schwede, D. 2013. The role of the atmosphere in the provision of ecosystem services. *Science of the Total Environment*, 448, 197-208.

Decina, S.M., Templer, P.H., Hutyra, L.R., Gately, C.K., Rao, P., 2017. Variability, drivers, and effects of atmospheric nitrogen inputs across an urban area: emerging patterns among human activities, the atmosphere, and soils. *Science of the Total Environment*, 609, 1524-1534.

Divers, M.T., Elliott, E.M., Bain, D.J., 2014. Quantification of nitrate sources to an urban stream using dual nitrate isotopes. *Environmental Science and Technology*, 48, 10580-10587.

Du, E., de Vries W., Galloway, J., Hu, X., Fang, J., 2014. Changes in wet nitrogen deposition in the United States between 1985 and 2012. *Environmental Research Letters*, 9, 095004.

Ellis R.A., Jacob, D.J., Sulprizio, M.P., Zhang, L., Holmes, C.D., Schichtel, B.A., Blett, T., Porter, E., Pardo, L.H., Lynch, J.A. 2013. Present and future nitrogen deposition to national parks in the United States: Critical load exceedances. *Atmospheric Chemistry and Physics*, 13, 9083–9095.

Fenn, M.E., Lambert, K.F., Blett, T.F., Burns, D.A., Pardo, J.H., Lovett, G.M., Haeuber, R.A., Evers, D.C., Driscoll, C.T., Jefferies, D.S. 2011. Setting limits: Using air pollution thresholds to protect and Restore U.S. Ecosystems. *Issues in Ecology*, Report No. 14.

FLAG, December 2000. Federal Land Managers' Air Quality Related Values Workgroup (FLAG) Phase I Report. United States Department of Interior National Park Service. Air Resources Division, Lakewood, Colorado. Published.
<http://www2.nature.nps.gov/air/permits/flag/index.cfm>.

Fowler, D., Coyle, M., Skiba, U., Sutton, M.A., Cape, J.N., Reis, S., Sheppard, L.J., Jenkins, A., Grizzeti, B., Galloway, J.N., Vitousek, P., Leach, A., Bouwman, A.F., Butterbach-Bahl, K., Dentener, F., Stevenson, D., Amann, M., Voss, M. 2013. The global nitrogen cycle in the twenty-first century. *Philosophical Transactions of the Royal Society B*, 368, 20130164.

Galloway, J.N., Aber, J.D., Erisman, J.W., Seitzinger, S.P., Howarth, R.W., Cowling, E.B., Cosby, J. 2003. The nitrogen cascade. *Bioscience*, 53, 341-356.

Jefferies, D., Ouimet, R. 2004. Critical loads: are they being exceeded? In: *The 2004 Canadian Acid Deposition Science Assessment*, Chapter 8. Environment Canada, Ottawa, Ontario, 341-370.

Jickells, T., Baker, A.R., Cape, J.N., Cornell, S.E., Nemitz, E. 2013. The cycling of organic nitrogen through the atmosphere. *Philosophical Transactions of the Royal Society-B Biological Sciences* 368, 20130115. <https://doi.org/10.1098/rstb.2013.0115>.

Li, Y., Schichtel, B.A., Walker, J.T., Schwede, D.B., Chen, X., Lehmann, C.M.B., Puchalski, M.A., Gay, D.A., Collett, J.L. 2016. Increasing importance of deposition of reduced nitrogen in the United States. *Proceedings of the National Academy of Sciences*, 113, 5874-5879.

Munns, W.R. Jr., Rea, A.W., Mazzotta, M.J., Wainger, L., Saterson, K. 2015. Toward a standard lexicon for ecosystem services. *Integrated Environmental Assessment and Management*, 11, 666-673.

Munns, W.R. Jr., Poulsen, V., Gala, W., Marshall, S.J., Rea, A.W., Sorensen, M., von Stackelberg, K., 2016a. Ecosystem services in risk assessment and management. *Integrated Environmental Assessment and Management*, 13, 62-73.

Munns, W.R. Jr., Rea, A.W., Suter, G.W. II, Martin L., Blake-Hedges L., Crk T., Davis C., Ferreira G., Jordan S., Mahoney M., Barron, M. 2016b. Ecosystem services as assessment endpoints for ecological risk assessment. *Integrated Environmental Assessment and Management*. 12, 522-528.

NPS, 2014. National Park Service. Nitrogen Critical Loads and Estimated Exceedances. <http://nature.nps.gov/air/Studies/criticalLoads/Ecoregions/index.cfm>.

Nilsson, J., Greenfelt, P. 1988. Critical levels for sulphur and nitrogen. 418 pp., Nordic Council of Minist. Copenhagen, Denmark.

Nowlan, C.R., Martin, R.V., Philip, S., Lamsal, L.N., Krotkov, N.A., Marais, E.A., Wang, S., and Zhang, Q. 2014. Global dry deposition of nitrogen dioxide and sulfur dioxide inferred from space-based measurements. *Global Biogeochem. Cycles*, 28, 1025–1043, doi: 10.1002/2014GB004805.

Pardo, L.H., Fenn, M.E., Goodale, C.L., Geiser, L.H., Driscoll, C.T., Allen, E.B., Baron, J.S., Bobbink, R., Bowman, W.D., Clark, C.M., Emmett, B., Gilliam, F.S., Greaver, T.L., Hall, S.J., Lilleskov, E.A., Liu, L., Lynch, J.A., Nadelhoffer, K.J., Perakis, S.S., Robin-Abbott, M.J., Stoddard, J.L., Weathers, K.C., and Dennis, R.L. 2011. Effects of nitrogen deposition and empirical nitrogen critical loads for ecoregions of the United States. *Ecological Applications* 21, 3049-3082.

Pardo, L.H., et al. 2015. Effects and Empirical Critical Loads of Nitrogen for Ecoregions of the United States. In: *Critical Loads and Dynamic Risk Assessments*. pp. 129-169, Springer, Netherlands.

Porter, E., Blett, T., Potter, D.U., Huber, C. 2005. Protecting resources on federal lands: implications of critical loads for atmospheric deposition of nitrogen and sulfur. *BioScience*, 55, 603-611.

Porter, E., Johnson, S. 2007. Translating science into policy: Using ecosystem thresholds to protect resources in Rocky Mountain National Park. *Environmental Pollution*, 149, 268-280.

Rea, A.W., Davis, C., Evans, D., Heninger, B., Van Houtven, G. 2012. Using ecosystem services to inform decisions on U.S. Air Quality Standards. *Environmental Science and Technology*, 46, 6481–6488.

Rhodes, C., Bingham, A., Heard, A.M., Hewitt, J., Lynch, J., Waite, R., and Bell, M.D. 2017. Diatoms to human uses: linking nitrogen deposition, aquatic eutrophication, and ecosystem services. *Ecosphere* 8, e01858.

SAB, 2011. Science Advisory Board to the U.S. Environmental Protection Agency. Reactive Nitrogen in the United States; an analysis of inputs, flows, consequences, and management Options. EPA-SAB-11-013. EPA, Washington, DC.

Scheffe, R.D., Lynch, J.A., Reff, A., Kelly J.T., Hubbell, B., Greaver, T.L., Smith, J.T. 2014. The Aquatic Acidification Index: A new regulatory metric linking atmospheric and biogeochemical models to assess potential aquatic ecosystem recovery. *Water Air Soil Pollution*, 225, 1838.

Schwede, D.B., Lear, G.G., 2014. A novel hybrid approach for estimating total deposition in the United States. *Atmospheric Environment*, 92, 207-220.

Thornes, J., et al. 2010. Communicating the value of atmospheric services. *Meteorological Applications*, 17, 243–50.

UNECE WGE. 2004. United Nations Economic Commission for Europe, Working Group on Effects. 2004 Joint Report of the International Cooperative Programmes and the Task Force on the Health Aspects of Air Pollution. United Nations Economic and Social Council Report EB.AIR/WG.1/2004/3.

U.S. Congress. 1977. United States Congress. Clean Air Act Amendments of 1977. P.L. 95-95. U.S. Government Printing Office, Washington, DC.

U.S. EPA. 1999. U.S. Environmental Protection Agency. Regional Haze Regulations. Final Rule, 40 CFR Part 51. Federal Register, 64(126), 35714-35774. U.S. Office of the Federal Register, National Archives and Records Administration, Washington, D.C.

U.S. EPA. 2005. U.S. Environmental Protection Agency. Prevention of Significant Deterioration for Nitrogen Oxides. Final Rule, 70 F.R. 5958. Federal Register, 70(202), 61081-61103. U.S. Office of the Federal Register, National Archives and Records Administration, Washington, D.C.

U.S. EPA. 2008. U.S. Environmental Protection Agency. Integrated Science Assessment for Oxides of Nitrogen and Sulfur – Ecological Criteria. EPA/600/R-08/082F. EPA, Research Triangle Park, NC.

U.S. EPA. 2009. U.S. Environmental Protection Agency. Risk and exposure assessment for review of the secondary national ambient air quality standards for oxides of nitrogen and oxides of sulfur-main content—final report. Tech. Rep. EPA-452/R-09-008a, EPA, Research Triangle Park, NC.

U.S. EPA. 2010. Chesapeake Bay Phase 5.3 Community Watershed Model. EPA 903S10002 - CBP/TRS-303-10. U.S. Environmental Protection Agency, Chesapeake Bay Program Office, Annapolis, MD. <http://ches.communitymodeling.org/models/CBPhase5/documentation.php>. Updated Run in December 2016.

U.S. EPA. 2011a. U.S. Environmental Protection Agency. Policy assessment for the review of the secondary national ambient air quality standards for oxides of nitrogen and oxides of sulfur—final report. Tech. Rep. EPA-452/R-11-005a, EPA, Research Triangle Park, NC.

U.S. EPA. 2011b. U.S. Environmental Protection Agency. CASAC Advice on the Policy Assessment for the Review of the Secondary National Ambient Air Quality Standards for Oxides of Nitrogen and Oxides of Sulfur (February 2011). EPA-CASAC-11-005, EPA, Research Triangle Park, NC.

U.S. EPA. 2012. U.S. Environmental Protection Agency. Secondary National Ambient Air quality Standards for Oxides of Nitrogen and Oxides of Sulfur. Final Rule, 40 CFR part 50. Federal Register, 77(64), 20218–20272. Office of the Federal Register, National Archives and Records Administration, Washington, D.C.

U.S. EPA. 2016. Integrated Science Assessment (ISA) for Oxides of Nitrogen, Oxides of Sulfur and Particulate Matter Ecological Criteria (First External Review Draft). U.S. Environmental Protection Agency, Washington, DC, EPA/600/R-16/372.

USFS. 2016. U.S. Forest Service. Critical Loads - Exceedance of Nutrient Nitrogen Critical Loads for Forests on Forest Service Lands.

http://www.srs.fs.usda.gov/airqualityportal/critical_loads/map_FOR.php

Acknowledgements: We acknowledge helpful technical and editorial comments from Pam Padgett and Tom Butler in the development of the report.

Disclaimer: The views expressed in this article are those of the authors and do not necessarily represent the views or policies of the U.S. EPA. Any opinions, findings, and conclusions or recommendations expressed in this publication are those of the authors and do not necessarily reflect the views of the program sponsors or the University of Wisconsin-Madison.